

Contents

Vacuum Pump Systems

Vacuum Pump Systems – oil sealed (RUTA) 523

General

Overview 523

Types of Pumps Systems 524

Products

Pump Systems

Oil Sealed Vacuum Pump Systems RUTA

Three-Stage Pump Systems

with Two-Stage TRIVAC Backing Pumps

Adaptor Version 526

Frame Version 528

Two-Stage Pump Systems

with Single-Stage SOGEVAC Backing Pumps

Adaptor Version 530

Frame Version 532

RBS - B/BCS Roots Pump Systems (Only available for purchase in North and South America)

with Two-Stage TRIVAC Backing Pumps. 538

HTS Close-Coupled Pump Systems (Only available for purchase in North and South America)

with Single-Stage SOGEVAC Backing Pumps. 542

Central Vacuum Supply Systems with SOGEVAC Pumps 546

Tank Mounted Medical Vacuum Systems (Only available for purchase in North and South America) 554

Vacuum Pump Systems - dry compressing (RUTA) 556

Products

Pump Systems

Dry Compressing Vacuum Pump System RUTA

with SCREWLINE Backing Pump

Adaptor Version

without palette 556

with palette 558

with SCREWLINE Backing Pump

Frame Version 562

Adaptor Version 568

SP Close-Coupled Pump Systems (Only available for purchase in North and South America)

with SCREWLINE Dry Compressing Backing Pumps 570

Further Products

Dry Compressing Vacuum Pump System RUTA

Adaptor Version

with DRYVAC DV 650 Backing Pump 574

Frame Version

with DRYVAC DV 650 Backing Pump 576

with DRYVAC DV 1200 Backing Pump 578

DRYVAC Pump Systems	
Adaptor Version	
Load Lock Pump Systems	580
Process Pump Systems	582
with RUVAC WH Backing Pump	584
enclosed	586
RUVAC RAV Roots Vacuum Pumps with Pre-Admission Cooling	588
TVD Pump Systems for Drying, Evaporation and Distillation Applications	590
Accessories for oil sealed and dry compressing Pump Systems	
Sound Proofing	592
Isolation against Vibrations	592
Dust Separators	592
Frequency Converter RUVATRONIC RT 5	592
Electric Controller	593
Pressure Control	593
Dust Filter F-xxx-C	594
Bellows with Vibration Absorbers	596
Bus Interfaces for Monitoring	597
Miscellaneous to oil sealed and dry compressing Pump Systems	
Checklist for Inquiries (Fax Form)	598
High Vacuum Pump Systems TMP	599
General	
General	599
Applications and Accessories	599
With oil sealed Forevacuum Pumps	600
Products	
Turbomolecular Pump Systems	
PT 50	600
PT 151 / PT 361 / PT 50 KIT	602
PT 151 / PT 361 KIT	606
With dry compressing Forevacuum Pumps	608
Products	
Turbomolecular Pump Systems	
PT 80 DRY / PT 80 H DRY	608
TURBOLAB 80	610
PT 151 DRY / PT 361 DRY	614
PT 300 DRY	618
Turbomolecular Pump Systems (Only available for purchase in North and South America)	
PT-Flex DRY	620

Accessories for High Vacuum Pump Systems TMP

Control Unit for Turbomolecular Pump Systems 624
 Adsorption Traps with Aluminium Oxide Insert. 625

UNIVEX High Vacuum Experimentation Systems..... 627

General

General 627
 Contents 628

Systems

Box Coating Systems 629
 Glove Box Systems 638
 Cluster-Tool Systems 644
 Dactyloscopy Systems 646
 Space Simulation Systems 647

Process Accessories 648

General Accessories 660

UNIVEX Questionnaire 662

Calibration Systems 664

General

CS Calibration Systems 664

Products

CS Calibration Systems 665

General to Vacuum Pump Systems

Overview

A continually increasing number of applications in industry and research are relying on vacuum technology. Thus widely differing requirements result regarding the vacuum generating systems.

The comprehensive range of vacuum pumps from Oerlikon Leybold Vacuum offers, in combination with the matching accessories, all options of selecting the optimum pump system for your application in each case.

Based on the longstanding experience in the design and manufacture of vacuum pump systems, Oerlikon Leybold Vacuum offers standardized pump systems which will match most applications – the RUTA pump systems.

RUTA pump systems excel by being compact, reliable and service-friendly.

The pump systems are equipped as standard with 400 V, 50 Hz three-phase motors.

Motors for special supply voltages, special mains frequencies or explosion protected pumps are available.

Standards

Oerlikon Leybold Vacuum pump systems are rated according to CE, ISO, DIN and VDE regulations. Compliance with other standards is possible upon request.

The technical data of the vacuum pump systems given in this catalog part are based on the PNEUROP Acceptance Specifications for Vacuum Pumps, Part 1, and comply with DIN 28 426. The characteristic curves in our pumping speed diagrams are plotted in accordance with DIN 28 426. The curves represent the mean of several measurements. Our warranty refers to the values indicated in the technical data table.

Designation of Roots Vacuum Pump Systems

Oerlikon Leybold Vacuum pump combinations of Roots vacuum pumps with backing pumps are called “RUTA”.

In order to identify the standard pump systems the name “RUTA” is followed by the brief designations of the pumps which make up a particular pump system.

Brief designation of the largest Roots vacuum pump (Pumping speed of the pump system)

Brief designation of the smaller Roots vacuum pump

Cooler or condenser (if present)

Brief designation of the backing pump

Type of pump system (adaptor (A) or frame (G))

The pump system designation is arranged as follows:

RUTA WAU 2001 / WAU 501 / K / D 65 B / G

Part Numbers

The part numbers listed refer in each case to the standard version of the respective systems. Minor deviations are indicated by way of variants.

The variant V001 designates in each case the described version of the system.

The pump system RUTA WAU 2001/ SP630 F/G has Part No. 502 511 V001. When using the air-cooled screw pump SCREWLINE SP 630 then the variant will have the Part No. 502 511 V002. Minor deviations are special operating voltage, fitted accessories and custom painting for frame or pumps, for example.

The use of a different type of Roots vacuum pump, use of the WS 2001 instead of the WAU 2001, for example, is also treated as a variant. All variants with the same basic number have the same frame dimensions, the same distance between intake flange of the Roots pump and the exhaust flange of the backing pump.

Types of Pump Systems

Typical areas of application for RUTA pump systems are industry, research and chemistry. Here the focus is on processes for metal production and processing, drying and degassing, thermal treatment, coating in the area of solar components and semiconductor manufacture as well as surface refinement. RUTA pump systems are also used as backing pump sets for high vacuum systems in combination with diffusion pumps, turbomolecular pumps and cryo pumps.



RUTA WH7000/4xSV750BF/G

The RUTA pump systems described here have been designed for rough and medium vacuum operation, i.e. for the pressure range from atmospheric pressure down to 10^{-4} mbar (0.75×10^{-4} Torr). RUTA pump systems consist of a combination of individual pumps whereby Roots vacuum pumps are employed on the intake side. Further compression to atmospheric pressure may be performed either by oil sealed or dry compressing vacuum pumps, liquid ring pumps or Roots vacuum pumps with pre-inlet cooling. All combinations may be equipped at suitable places with condensers.

The selection criteria for a RUTA pump system are as follows:

- Pumping speed
- Operating pressure
- Process conditions
- Characteristics of the media
- Standards and regulations which depend on the area of application and the produced products.

Standard RUTA Pump Systems

Our Roots vacuum pumps WA, WH, WS and RA or WAU and WSU with integrated bypass line are combined with oil sealed backing pumps for conventional generation of the vacuum. Single-stage arrangements are capable of delivering pumping speeds of 250 to 16000 m³/h (147.3 to 9424 cfm). Higher pumping speeds can be attained by paralleling several pumps. The attainable operating pressures depend on the number of pumping stages.

For higher pumping speeds or lower ultimate pressures, also three-stage or multi-stage pump systems are available.

RUTA Pump Systems with Condensers

If vacuum systems must pump larger quantities of vapor or vapor gas mixtures, it is economical to insert condensers which are cooled with water or a different coolant at a suitable place within the pump system. Cooled condensers are themselves effective partial pumps which condense most of the vapors from the pumped media. The downstream mechanical pumps will then only need to pump those gases which have not already condensed.

The quantity of vapor present in each case determines the size of the condenser and the temperature at which it is operated. The size of the downstream pump is determined by the quantity of non-condensable gases, the required pressure and the required pump-down time for the system.

All pump systems of the WA/WAU, WS/WSU, WH and RA series may be equipped with one or several condensers. These are often used in the chemical industry. Here RUTA vacuum pump systems with condensers are not only used to generate a vacuum, but they are also often employed in the recovery of solvents. When installing one or several Roots pumps upstream of a condenser, low operating pressures and high condensation pressures can be attained. Thus the condenser may in many cases be operated with cooling water instead of brine. The vapor components pumped together with inert gases may be separated once more in an emission condenser on the exhaust side so that the quality of the exhaust gas can be maintained within close tolerance regarding its cleanness.

Dry Compressing RUTA Vacuum Pump Systems

Increasing environmental awareness, pumping of condensable vapors or high requirements regarding cleanness when pumping high quality media which must not be contaminated by other media for recycling, often requires the use of universal pumps where the pump chamber is free of operating agents (dry pumps).

Here Oerlikon Leybold Vacuum offers two solutions:

1. Pump systems with dry compressing vacuum pumps combined with one or several Roots vacuum pumps.
2. Single-stage RUTA RAV vacuum pump systems, consisting of Roots vacuum pumps with pre-admission cooling.

The operating pressure ranges of the pump systems depend on the number of Roots vacuum pumps, but will extend in any case without interruptions to atmospheric pressure.

Already in connection with one Roots pump, pump systems with a screw pump are capable of attaining base pressures of $< 1 \times 10^{-3}$ mbar (7.5×10^{-4} Torr).

Single-stage RAV combinations attain an ultimate pressure of 150 mbar (112.5 Torr).

Multi-stage combinations with Roots vacuum pumps of all systems are capable of attaining pressures below 10^{-4} mbar (7.5×10^{-5} Torr).

RUTA Custom Pump Systems

Most users will be able to select the right pump system for their application from our range of standard pump systems. In special cases a custom design may be required for special processes and high pumping speeds.

We are prepared to design and manufacture custom pump systems according to customers specifications. If required we will use - besides oil-sealed and dry compressing backing pumps - liquid ring and ejector pumps.

RUTA Pump Systems for the Metal Producing and Processing Industry

In common vacuum furnace processes such as hardening, annealing, brazing, melting and casting, preferably oil sealed or dry compressing standard vacuum pump systems are usually used.

The oil sealed systems consist of a combination of Roots vacuum pumps with a single or two-stage rotary vane or rotary piston pump.

In the dry compressing systems our screw vacuum pump SCREWLINE is used as the backing pump.

The vacuum pumps are mounted in a rugged frame. The design of the pump systems is service-friendly, modular and can be easily upgraded with additional equipment.

On smaller furnaces RUVAC WAU Roots vacuum pumps are the most suitable because these may be cut-in at a higher operating pressure, while on larger furnaces and particularly where short pump-down cycles are required, the use of RUVAC WH Roots vacuum pumps with suitably sized backing pumps is advisable. For special processes, e.g. fusion or degassing of molten masses, due to the high dust contents, the additional use of a dust separator is required as well as equipping the backing pumps with oil filtering units.

These additional units ensure utmost operational reliability of the pump systems even under the toughest operating conditions.

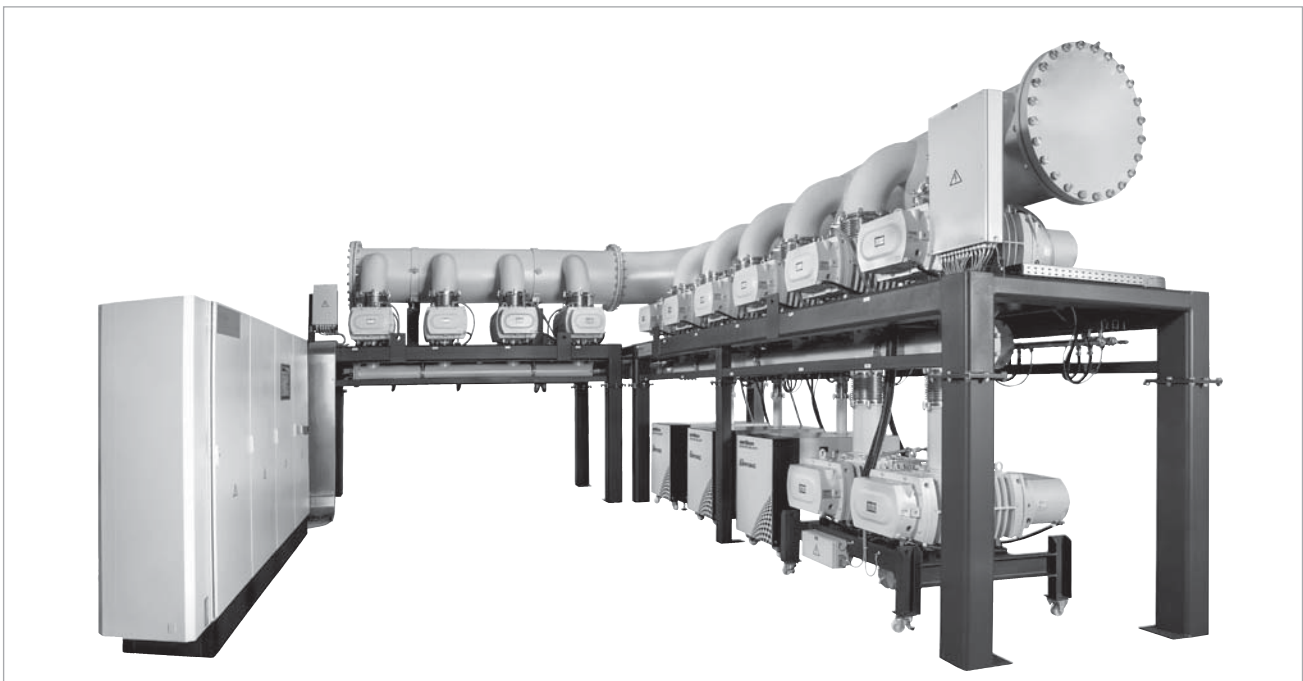

Pump system for the field of steel degassing

RUTA Pump Systems for the Photovoltaic and Coating Industry

In photovoltaic coating processes reactive, toxic and corrosive substances are generally used.

Frequently large quantities of dust for the pump system need to be expected. For such applications, Oerlikon Leybold Vacuum has developed process pump combinations consisting of pumps from the DRYVAC line and Roots pumps from the RUVAC WS/WH line with optionally integrated controller.

The integrated electronics and sensor systems permit easy integration of the pump systems within the plant control system.

(For information on possible applications, see Catalog Part "Dry Compressing Screw Vacuum Pumps DRYVAC").

RUTA Pump Systems for the Chemical Industry

In chemical processes it is often necessary to remove corrosive, condensable and reactive gases and vapors. Oerlikon Leybold Vacuum designs and manufactures custom-built pump systems for specific process applications. Depending on the type of application, either a rotary vane pump, or a dry compressing screw vacuum pump (SCREWLINE, for example), a liquid ring pump or a combination of gas jet pump and liquid ring pump may be used as the backing pump.

To ensure dependable monitoring of the system, the following monitoring devices, among others, may be installed:

- Temperature sensors to monitor the gas temperatures between the pump stages and the pump body temperature,
- Water flow monitors for the cooling water supply to pumps and condensers,
- Differential pressure indicator with control setpoint to monitor the exhaust filters of the rotary vane vacuum pump.

Pump Systems for Drying, Evaporation and Distillation Applications (TVD)

More and more vacuum applications are finding their way into the areas of environmental protection, recycling and waste disposal. "Waste disposal of used oil and aromatic compounds" and "Cleaning processes in metal-processing factories" demonstrate that the combination of vacuum know-how, innovative engineering and applications know-how is in-dispensable for the successful application of vacuum technology in most widely differing applications.



TVD pump system, mobile with control cabinet

The product is no longer in the foreground, solutions to problems are demanded instead.

Oerlikon Leybold Vacuum has developed some continuously operating vacuum pump systems for these applications. These systems basically consist of a rotary vane pump with a condenser unit. Upon request the condenser arrangement may also be equipped with a cold water set. This version will then be independent of any cooling water connections and - being a mobile system - it is well-suited for operation at varying locations.

Products

Oil Sealed RUTA Pump Systems Three-Stage, with Two-Stage TRIVAC Backing Pumps, Adaptor Version

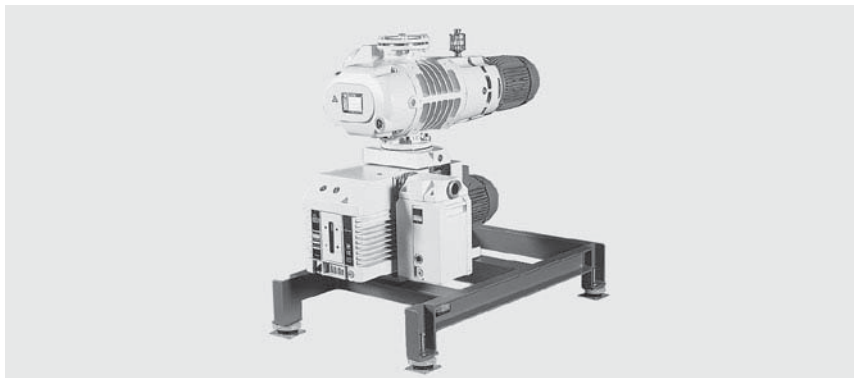

RUTA WAU501/D65B/A

Standard Equipment

- Exhaust filter
- Oil collecting pan
- Manually operated gas ballast
- Crane eyes on the frame
- Floor mounting
- The oil is supplied with the pump
- CE approval

Options

- Frequency converter RUVATRONIC RT for controlling the speed of the Roots pump
- Oil filter
- 24 V DC gas ballast valve
- Sound proofing box
- Vibration absorbers
- Castors
- Different types of floor mounts
- Oil drain valve on each pump
- Exhaust filter with oil return line
- Special motors
- Electric control systems

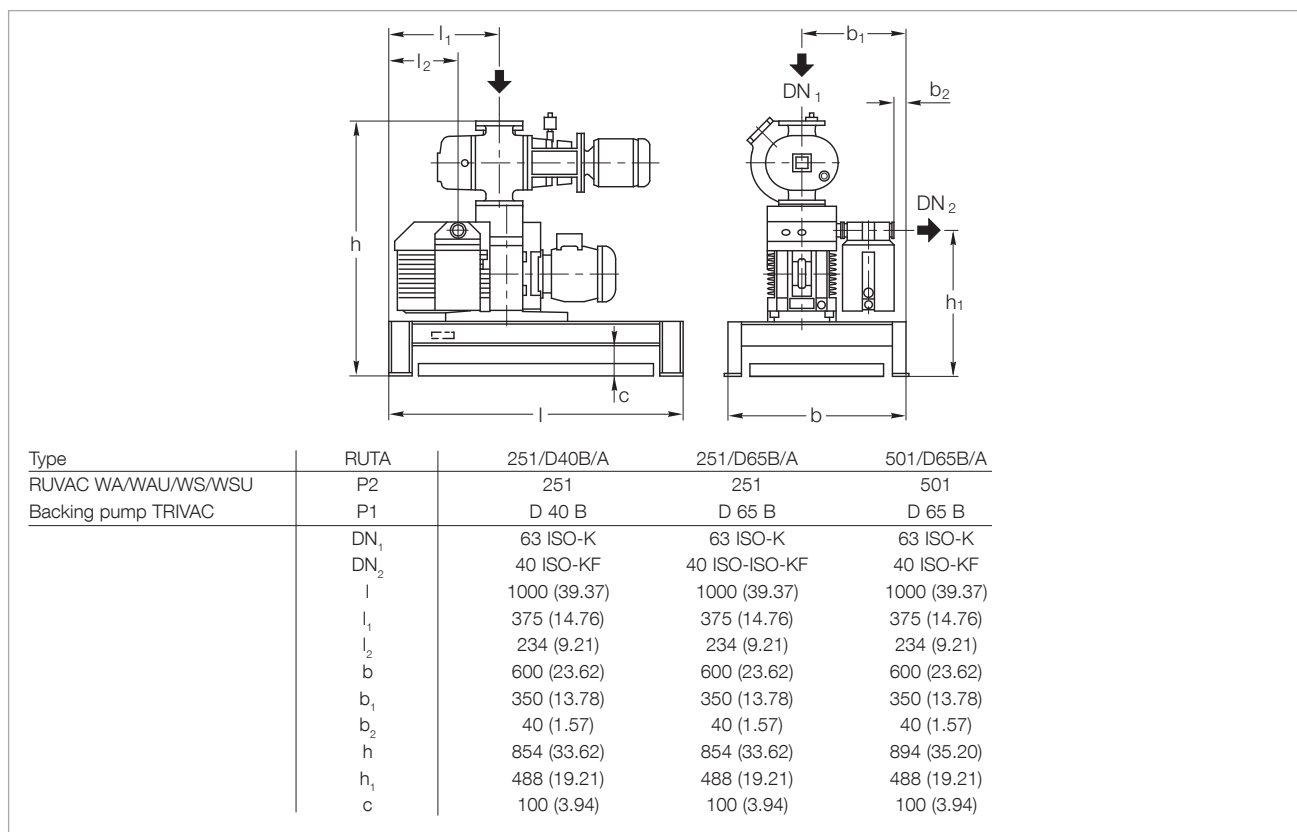

Dimensional drawing for the pump systems with TRIVAC D40/65 B backing pumps on pallet; dimensions in brackets () are in inch

Technical Data, 50 Hz

RUTA WAU

		251/D40B/A	251/D65B/A	501/D65B/A
RUVAC (WA/WAU/WS/WSU possible)	P2	251	251	501
Backing pump TRIVAC	P1	D 40 B	D 65 B	D 65 B
Pumping speed, 50 Hz at 10^{-1} mbar (7.5×10^{-2} Torr)	$m^3 \times h^{-1}$ (cfm)	200.0 (117.8)	210.0 (123.7)	380.0 (223.8)
Ultimate partial pressure	mbar (Torr)	$< 2 \times 10^{-5}$ ($< 1.5 \times 10^{-5}$)	$< 2 \times 10^{-5}$ ($< 1.5 \times 10^{-5}$)	$< 2 \times 10^{-5}$ ($< 1.5 \times 10^{-5}$)
Ultimate total pressure with gas ballast	mbar (Torr)	$< 8 \times 10^{-4}$ ($< 6 \times 10^{-4}$)	$< 8 \times 10^{-4}$ ($< 6 \times 10^{-4}$)	$< 8 \times 10^{-4}$ ($< 6 \times 10^{-4}$)
Installed motor power 400 V, 50 Hz	kW (hp)	2.6 (3.5)	3.3 (4.5)	4.4 (6.0)
Electrical power consumption at 10^{-1} mbar (7.5×10^{-2} Torr)	kW (hp)	2.0 (2.7)	2.5 (3.4)	2.7 (3.7)
Noise level				
max.	dB(A)	64	65	67
without gas ballast at 1 mbar (0.75 Torr)	dB(A)	62	63	63
Oil filling, total, approx.	l (qt)	3.3 (3.49)	4.0 (4.23)	4.3 (4.55)
Weight, total, approx.	kg (lbs)	245.0 (540.2)	260.0 (573.3)	305.0 (627.5)
Connecting flange				
Inlet port	DN ₁	63 ISO-K	63 ISO-K	63 ISO-K
Outlet port	DN ₂	40 ISO-KF	40 ISO-KF	40 ISO-KF

Ordering Information

RUTA WAU

		251/D40B/A	251/D65B/A	501/D65B/A
		Part No.	Part No.	Part No.
RUVAC (WA/WAU/WS/WSU possible)	P2	WAU 251	WAU 251	WAU 501
Backing pump TRIVAC	P1	D 40 B	D 65 B	D 65 B
Pump system, complete (adaptor version), pallet mounted, with Roots vacuum pump RUVAC WAU		023 06	023 07	023 08
Frequency converter RUVATRONIC (see description in Chapter "Accessories")		RT 5/251 500 001 381	RT 5/251 500 001 381	RT 5/501 500 001 382

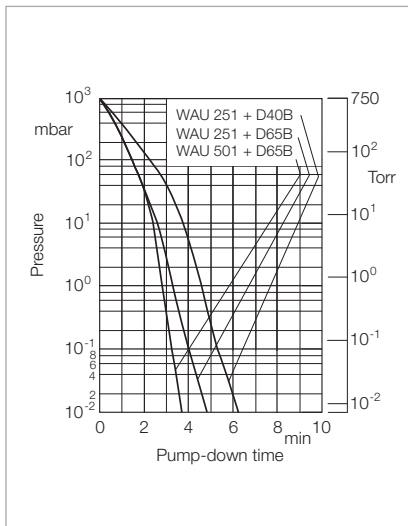

Pump-down time diagram for a 1000 l tank at 50 Hz

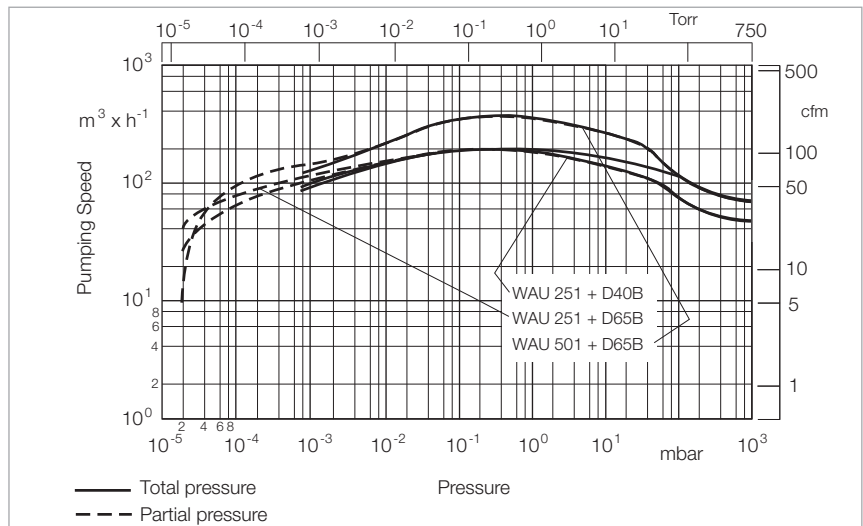

Pumping speed diagram at 50 Hz

Oil Sealed RUTA Pump Systems Three-Stage, with Two-Stage TRIVAC Backing Pumps, Frame Version

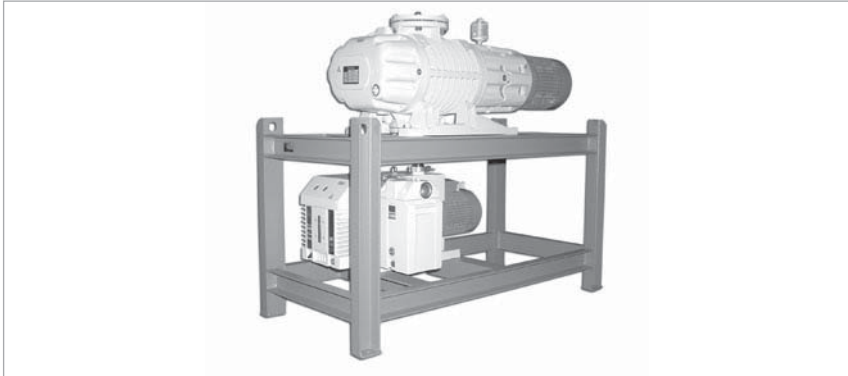

RUTA WAU501/D65B/G

Standard Equipment

- Exhaust filter
- Oil collecting pan
- Manually operated gas ballast
- Crane eyes on the frame
- Floor mounting
- The oil is supplied with the pump
- CE approval

Options

- Frequency converter RUVATRONIC RT for controlling the speed of the Roots pump
- Oil filter
- 24 V DC gas ballast valve
- Sound proofing box
- Vibration absorbers
- Castors
- Different types of floor mounts
- Oil drain valve on each pump
- Exhaust filter with oil return line
- Special motors
- Electric control systems

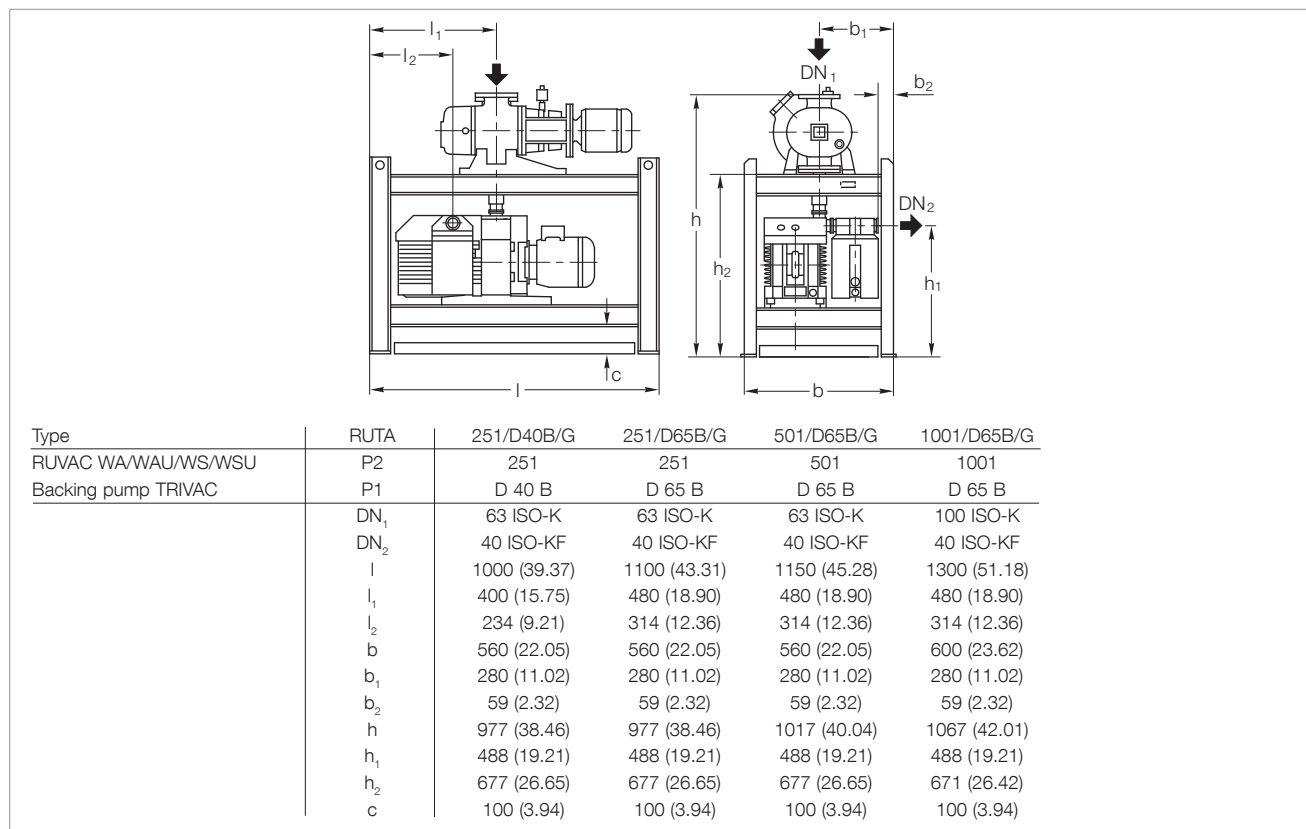

Dimensional drawing for the pump systems with TRIVAC D40/65 B backing pumps in a frame; dimensions in brackets () are in inch

Technical Data, 50 Hz

RUTA WAU

		251/D40B/G	251/D65B/G	501/D65B/G	1001/D65B/G
RUVAC (WA/WAU/WS/WSU possible)	P2	251	251	501	1001
Backing pump TRIVAC	P1	D 40 B	D 65 B	D 65 B	D 65 B
Pumping speed, 50 Hz at 10^{-1} mbar (7.5×10^{-2} Torr)	$m^3 \times h^{-1}$ (cfm)	185.0 (109.0)	205.0 (120.7)	340.0 (200.3)	620.0 (365.2)
Ultimate partial pressure	mbar (Torr)	$< 2 \times 10^{-5}$ ($< 1.5 \times 10^{-5}$)	$< 2 \times 10^{-5}$ ($< 1.5 \times 10^{-5}$)	$< 2 \times 10^{-5}$ ($< 1.5 \times 10^{-5}$)	$< 2 \times 10^{-5}$ ($< 1.5 \times 10^{-5}$)
Ultimate total pressure with gas ballast	mbar (Torr)	$< 8 \times 10^{-4}$ ($< 6 \times 10^{-4}$)	$< 8 \times 10^{-4}$ ($< 6 \times 10^{-4}$)	$< 8 \times 10^{-4}$ ($< 6 \times 10^{-4}$)	$< 8 \times 10^{-4}$ ($< 6 \times 10^{-4}$)
Installed motor power 400 V, 50 Hz	kW (hp)	2.6 (3.5)	3.3 (4.5)	4.4 (6.0)	6.2 (8.4)
Electrical power consumption at 10^{-1} mbar (7.5×10^{-2} Torr)	kW (hp)	2.0 (2.7)	2.5 (3.4)	2.7 (3.7)	3.0 (4.1)
Noise level max. without gas ballast at 1 mbar (0.75 Torr)	dB(A)	64	65	67	77
	dB(A)	62	63	63	70
Oil filling, total, approx.	l (qt)	3.3 (4.5)	4.0 (4.23)	4.3 (4.55)	5.3 (5.60)
Weight, total, approx.	kg (lbs)	280.0 (617.4)	310.0 (683.6)	350.0 (771.8)	460.0 (1014.3)
Connecting flange Inlet port Outlet port	DN ₁ DN ₂	63 ISO-K 40 ISO-KF	63 ISO-K 40 ISO-KF	63 ISO-K 40 ISO-KF	100 ISO-K 40 ISO-KF

Ordering Information

RUTA WAU

		251/D40B/G	251/D65B/G	501/D65B/G	1001/D65B/G
		Part No.	Part No.	Part No.	Part No.
RUVAC (WA/WAU/WS/WSU possible)	P2	WAU 251	WAU 251	WAU 501	WAU 1001
Backing pump TRIVAC	P1	D 40 B	D 65 B	D 65 B	D 65 B
Pump system, complete (frame version), frame mounted, with Roots vacuum pump RUVAC WAU		023 16	023 17	023 18	023 19
Frequency converter RUVATRONIC (see description in Chapter "Accessories")		RT 5/251 500 001 381	RT 5/251 500 001 381	RT 5/501 500 001 382	RT 5/1001 500 001 383

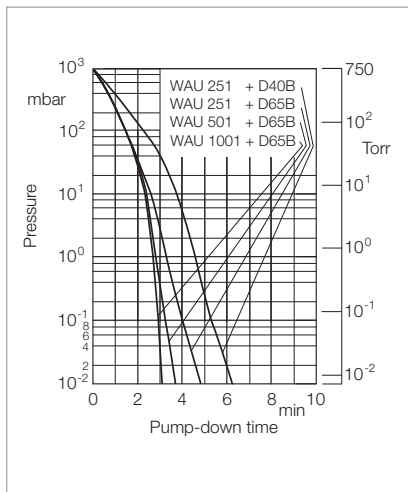

Pump-down time diagram for a 1000 l tank at 50 Hz

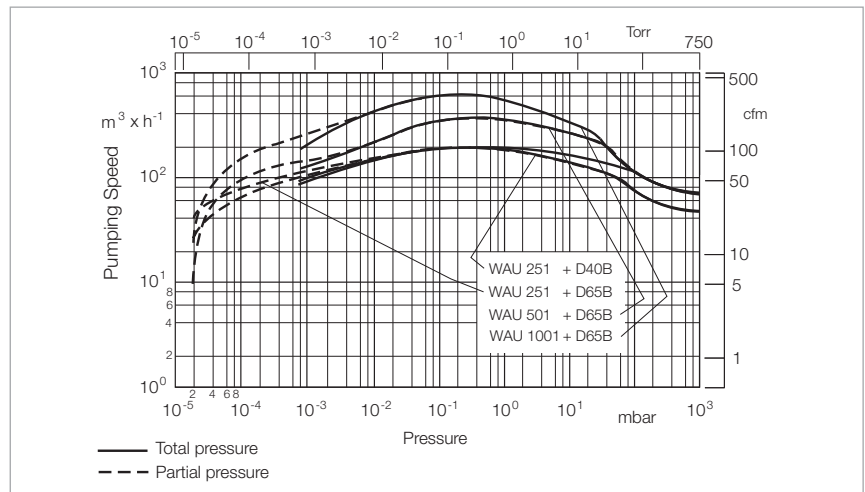

Pumping speed diagram at 50 Hz

Oil Sealed RUTA Pump Systems Two-Stage, with Single-Stage SOGEVAC Backing Pumps, Adaptor Version

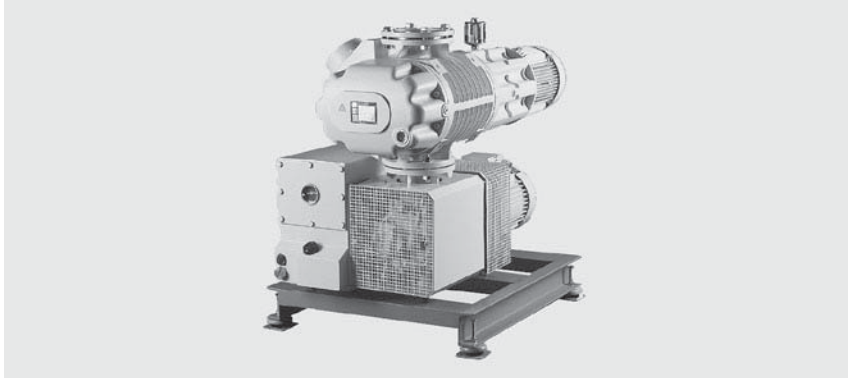

RUTA WAU1001/SV200/A

Standard Equipment

- Exhaust filter with oil return line
- Oil filter
- Oil collecting pan
- Gas ballast valve:
SV 200/300 B manually operated
SV 630 BF 24 V DC
- SV 200/300 B with air cooling
- SV 630 BF with water cooling
- Floor mounting

- The oil is supplied with the pump
- CE approval

- Sound proofing box
- Vibration absorbers
- Castors

Options

- Frequency converter
RUVATRONIC RT for controlling the
speed of the Roots pump
- 24 V DC gas ballast valve or manu-
ally operated

- Different types of floor mounts
- Oil drain valve on each pump
- Special motors
- Electric control systems

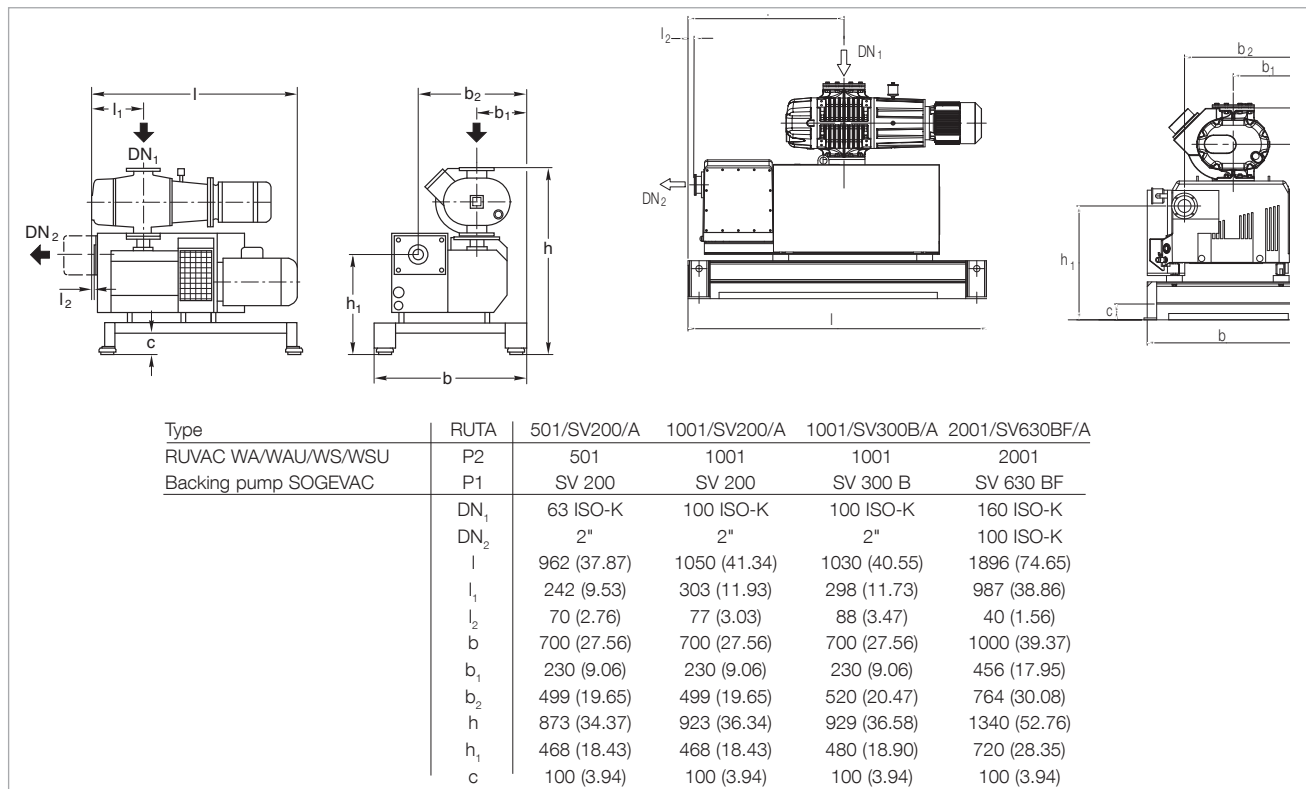

Dimensional drawing for the pump systems with SOGEVAC SV 200 and 300 B backing pumps [left], SOGEVAC SV 630 BF [right]; dimensions in brackets () are in inch

Technical Data, 50 Hz

RUTA WAU

501/SV200/A 1001/SV200/A 1001/SV300B/A 2001/SV630BF/A

RUVAC (WA/WAU/WS/WSU possible)	P2	501	1001	1001	2001
Backing pump SOGEVAC	P1	SV 200	SV 200	SV 300 B	SV 630 BF
Pumping speed, 50 Hz at 10^{-1} mbar (7.5×10^{-2} Torr)	$\text{m}^3 \times \text{h}^{-1}$ (cfm)	365.0 (215.0)	715.0 (421.0)	730.0 (430.0)	1690.0 (995.4)
Ultimate partial pressure	mbar (Torr)	$< 8 \times 10^{-3}$ ($< 6 \times 10^{-3}$)	$< 8 \times 10^{-3}$ ($< 6 \times 10^{-3}$)	$< 8 \times 10^{-3}$ ($< 6 \times 10^{-3}$)	$< 8 \times 10^{-3}$ ($< 6 \times 10^{-3}$)
Ultimate total pressure with gas ballast	mbar (Torr)	$< 4 \times 10^{-2}$ ($< 3 \times 10^{-2}$)	$< 4 \times 10^{-2}$ ($< 3 \times 10^{-2}$)	$< 4 \times 10^{-2}$ ($< 3 \times 10^{-2}$)	$< 4 \times 10^{-2}$ ($< 3 \times 10^{-2}$)
Installed motor power 400 V, 50 Hz	kW (hp)	6.2 (8.4)	8.0 (10.9)	9.5 (12.9)	22.5 (30.6)
Electrical power consumption at 10^{-1} mbar (7.5×10^{-2} Torr)	kW (hp)	3.0 (4.1)	3.5 (4.8)	4.0 (5.4)	16.5 (22.4)
Noise level without gas ballast at 10^{-1} mbar (7.5×10^{-2} Torr)	dB(A)	70	75	76	80
Oil filling, total, approx.	l (qt)	6.0 (6.34)	7.0 (7.4)	11.0 (11.63)	26.0 (27.47)
Weight, total, approx.	kg (lbs)	335.0 (738.7)	430.0 (948.2)	480.0 (1058.4)	1140.0 (2513.7)
Connecting flange					
Inlet port	DN ₁	63 ISO-K	100 ISO-K	100 ISO-K	160 ISO-K
Outlet port	DN ₂	2"	2"	2"	100 ISO-K

Ordering Information

RUTA WAU

501/SV200/A 1001/SV200/A 1001/SV300B/A 2001/SV630BF/A

		Part No.	Part No.	Part No.	Part No.
RUVAC (WA/WAU/WS/WSU possible)	P2	WAU 501	WAU 1001	WAU 1001	WAU 2001
Backing pump SOGEVAC	P1	SV 200	SV 200	SV 300 B	SV 630 BF
Pump system, complete (adaptor version), pallet mounted, with Roots vacuum pump RUVAC WAU		022 06	022 08	502 462 V001	502 463 V001
Frequency converter RUVATRONIC (see description in Chapter "Accessories")		RT 5/501	RT 5/1001	RT 5/1001	RT 5/2001
		500 001 382	500 001 383	500 001 383	500 001 384

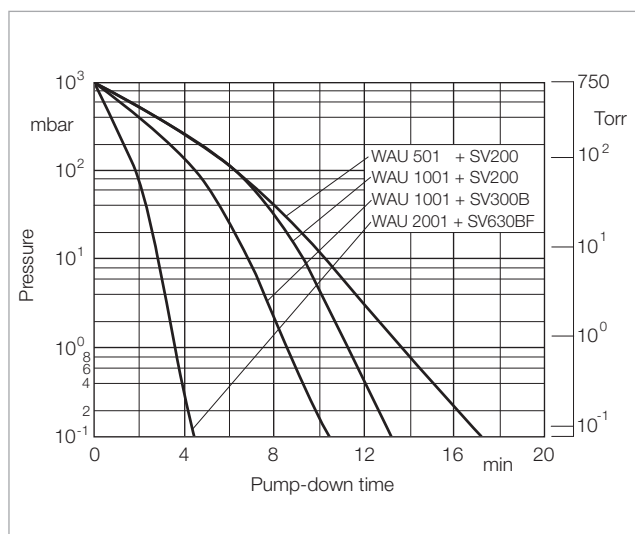

Pump-down time diagram for a 10 m³ tank at 50 Hz

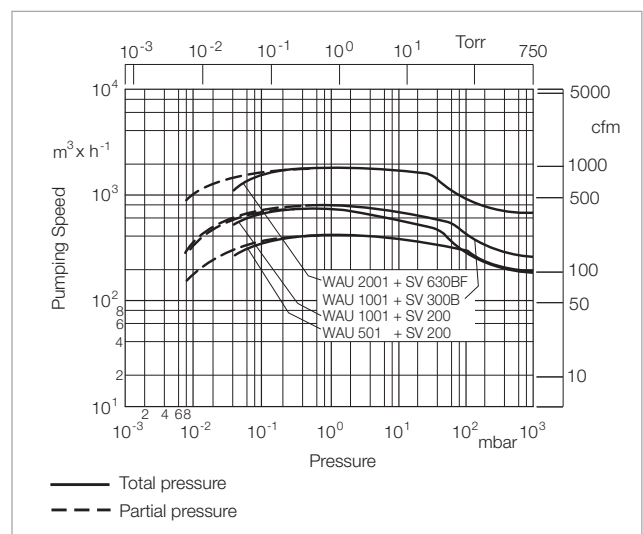

Pumping speed diagram at 50 Hz

Oil Sealed RUTA Pump Systems Two-Stage, with Single-Stage SOGEVAC Backing Pumps, Adaptor Version

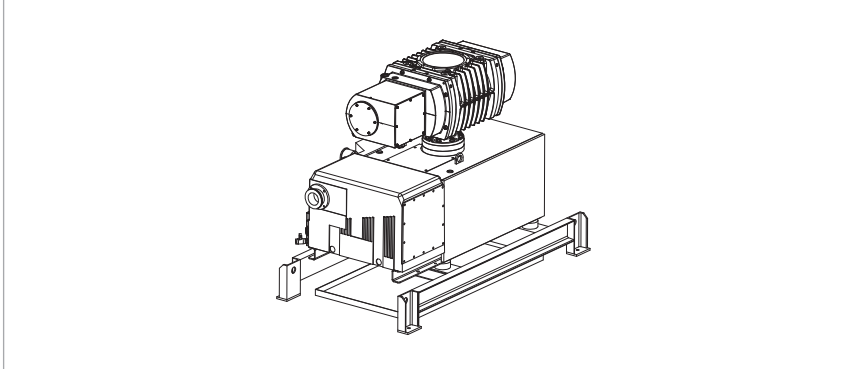

RUTA WH4400/SV630BF/A

Standard Equipment

- RUVAC WH with water cooling
- Exhaust filter with oil return line
- Oil filter
- Oil collecting pan
- Gas ballast valve:
SV 100 to 300 manually operated
SV 630 BF 24 V DC
- SV 100 to 300 with air cooling
- SV 630 BF with water cooling

- Floor mounting
- The oil is supplied with the pump
- RUVAC WH including external frequency converter (frequency converter permits pumping speed control)
- CE approval

Options

- 24 V DC gas ballast valve or manually operated
- Sound proofing box
- Vibration absorbers
- Castors
- Different types of floor mounts
- Oil drain valve on each pump
- Special motors
- Electric control systems

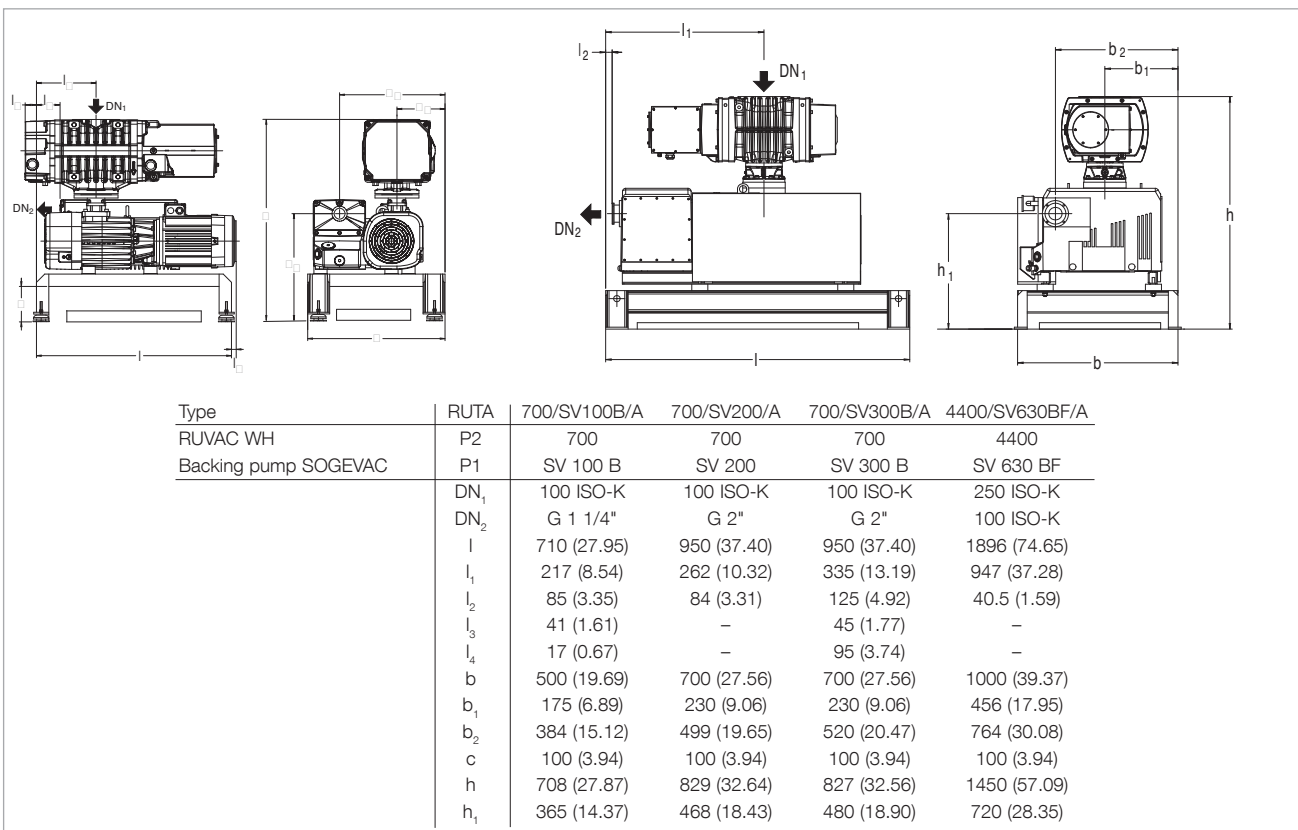

Dimensional drawing for the pump systems with SOGEVAC SV 100 B, 200 and 300 B backing pumps [left], SOGEVAC SV 630 BF [right]; dimensions in brackets () are in inch

Technical Data, 50 Hz

RUTA WH

		700/SV100B/A	700/SV200/A	700/SV300B/A	4400/SV630BF/A
RUVAC WH	P2	700	700	700	4400
Backing pump SOGEVAC	P1	SV 100 B	SV 200	SV 300 B	SV 630 BF
Pumping speed, 50 Hz at 10^{-1} mbar (7.5×10^{-2} Torr)	$\text{m}^3 \times \text{h}^{-1}$ (cfm)	520 (306)	570 (335)	600 (353)	3332 (1961)
Ultimate pressure without gas ballast	mbar (Torr)	$< 5 \times 10^{-3}$ ($< 3.75 \times 10^{-3}$)	$< 2 \times 10^{-3}$ ($< 1.5 \times 10^{-3}$)	$< 3 \times 10^{-3}$ ($< 2.25 \times 10^{-3}$)	$< 3 \times 10^{-3}$ ($< 2.25 \times 10^{-3}$)
Installed motor power 400 V, 50 Hz	kW (hp)	4.4 (5.9)	6.2 (8.3)	7.7 (10.3)	26.0 (34.9)
Electrical power consumption at 10^{-1} mbar (7.5×10^{-2} Torr)	kW (hp)	1.6 (2.2)	2.9 (3.9)	6.0 (8.0)	9,68 (12.98)
Noise level at 10^{-1} mbar (7.5×10^{-2} Torr)	dB(A)	62	69	70	73
Oil filling, total, approx.	l (qt)	2.9 (2.6)	9.9 (8.7)	12.4 (10.9)	27.0 (23.8)
Weight, approx.	kg (lbs)	350 (722)	415 (915)	465 (1025)	1330 (2932)
Connecting flange					
Inlet port	DN ₁	100 ISO-K	100 ISO-K	100 ISO-K	250 ISO-K
Outlet port	DN ₂	G 1 1/4"	G 2"	G 2"	100 ISO-K

Ordering Information

RUTA WH

		700/SV100B/A	700/SV200/A	700/SV300B/A	4400/SV630BF/A
RUVAC WH	P2	700	700	700	4400
Backing pump SOGEVAC					
air-cooled	P1	SV 100 B	SV 200	SV 300 B	-
water-cooled	P1	-	-	-	SV 630 BF
Pump system, complete (adaptor version), pallet mounted, with Roots vacuum pump RUVAC WH		503155V001 ¹⁾	503156V001 ¹⁾	503157V001 ¹⁾	503164V001 ¹⁾

¹⁾ Including external frequency converter

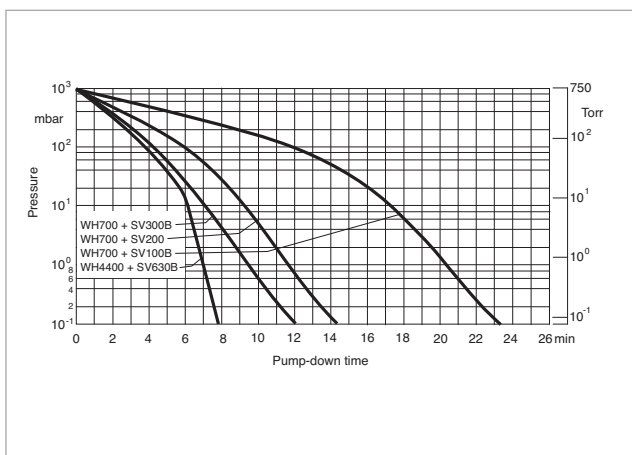

Pump-down time diagram for a 10 m^3 tank at 50 Hz

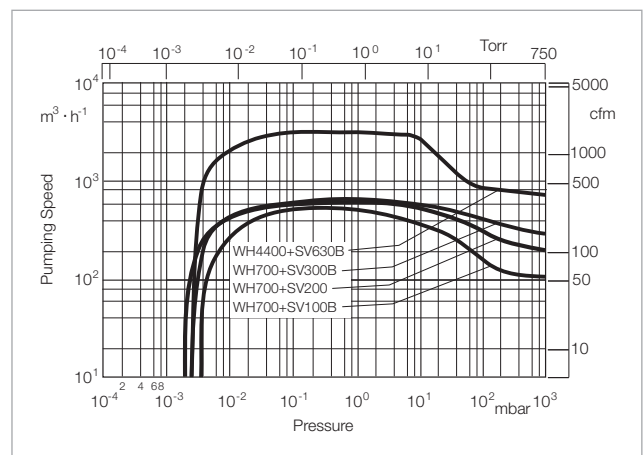

Pumping speed diagram at 50 Hz

Oil Sealed RUTA Pump Systems Two-Stage, with Single-Stage SOGEVAC Backing Pumps, Frame Version

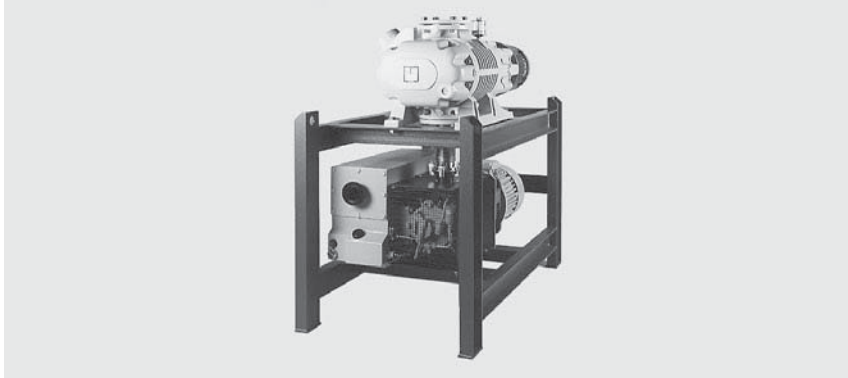

RUTA WAU2001/SV300B/G

Standard Equipment

- RUVAC WAU with air cooling
- SOGEVAC SV 300 B with air cooling
- Exhaust filter with oil return line
- Oil filter
- Oil collecting pan
- Gas ballast valve: SV 300 B manually operated
- Crane eyes on the frame
- Floor mounting
- The oil is supplied with the pump
- CE approval

Options

- Frequency converter RUVATRONIC RT for controlling the speed of the Roots pump
- 24 V DC gas ballast valve or manually operated
- Sound proofing box
- Vibration absorbers
- Castors
- Different types of floor mounts
- Oil drain valve on each pump
- Special motors
- Electric control systems

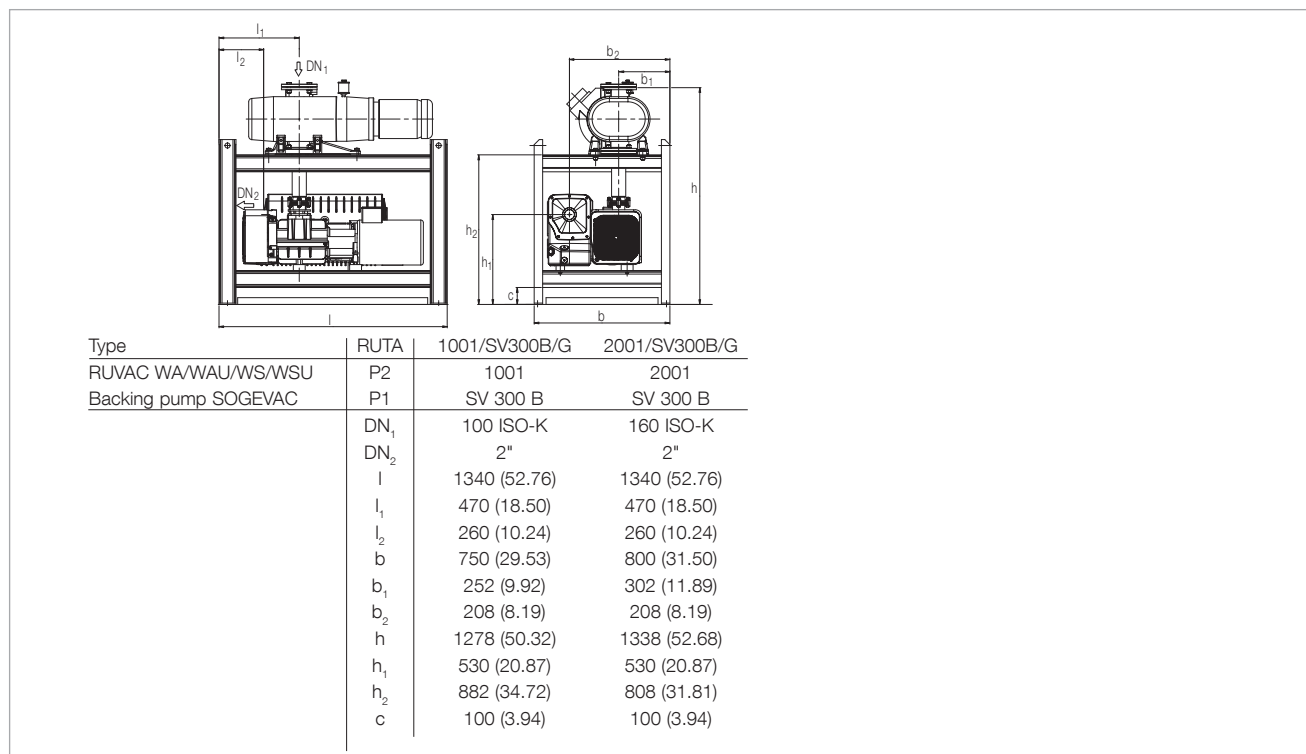

Dimensional drawing for the pump systems with SOGEVAC SV 300 B backing pumps; dimensions in brackets () are in inch

Technical Data, 50 Hz

RUTA WAU

1001/SV300B/G

2001/SV300B/G

RUVAC (WA/WAU/WS/WSU possible)	P2	1001	2001
Backing pump SOGEVAC	P1	SV 300 B	SV 300 B
Pumping speed, 50 Hz at 10^{-1} mbar (7.5×10^{-2} Torr)	$\text{m}^3 \times \text{h}^{-1}$ (cfm)	730 (430)	1445 (850)
Ultimate partial pressure	mbar (Torr)	$< 8 \times 10^{-3}$ ($< 6 \times 10^{-3}$)	$< 8 \times 10^{-3}$ ($< 6 \times 10^{-3}$)
Ultimate total pressure with gas ballast	mbar (Torr)	$< 4 \times 10^{-2}$ ($< 3 \times 10^{-2}$)	$< 4 \times 10^{-2}$ ($< 3 \times 10^{-2}$)
Installed motor power 400 V, 50 Hz	kW (hp)	9.5 (12.9)	13.0 (17.7)
Electrical power consumption at 10^{-1} mbar (7.5×10^{-2} Torr)	kW (hp)	4.0 (5.4)	4.5 (6.1)
Noise level without gas ballast at 10^{-1} mbar (7.5×10^{-2} Torr)	dB(A)	75	79
Oil filling, total, approx.	l (qt)	11 (11.63)	13 (13.74)
Weight, total, approx.	kg (lbs)	560.0 (1234.8)	740.0 (1631.7)
Connecting flange			
Inlet port	DN ₁	100 ISO-K	160 ISO-K
Outlet port	DN ₂	2"	2"

Ordering Information

RUTA WAU

1001/SV300B/G

2001/SV300B/G

		Part No.	Part No.
RUVAC (WA/WAU/WS/WSU possible)	P2	WAU 1001	WAU 2001
Backing pump SOGEVAC	P1	SV 300 B	SV 300 B
Pump system, complete (frame version), frame mounted, with Roots vacuum pump RUVAC WAU		502 452 V001	502 453 V001
Frequency converter RUVATRONIC (see description in Chapter "Accessories")		RT 5/1001 500 001 383	RT 5/2001 500 001 384

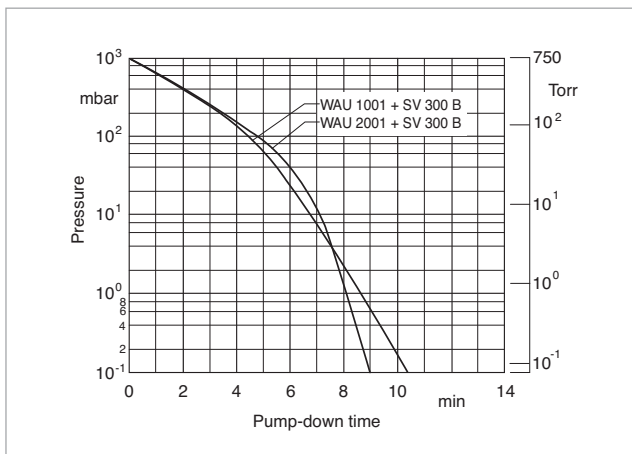

Pump-down time diagram for a 10 m³ tank at 50 Hz

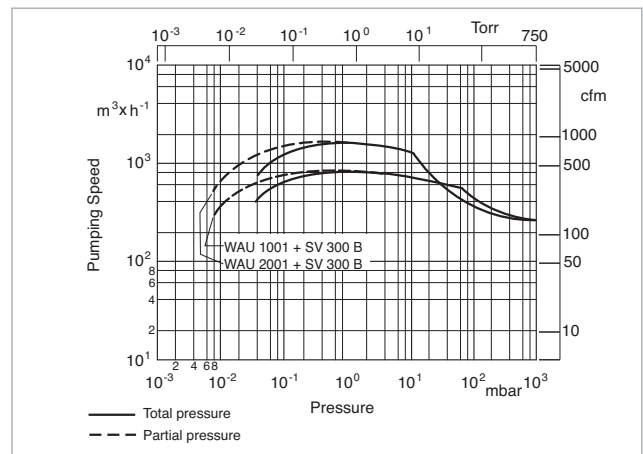

Pumping speed diagram at 50 Hz

Oil Sealed RUTA Pump Systems Two-Stage, with Single-Stage SOGEVAC Backing Pumps, Frame Version

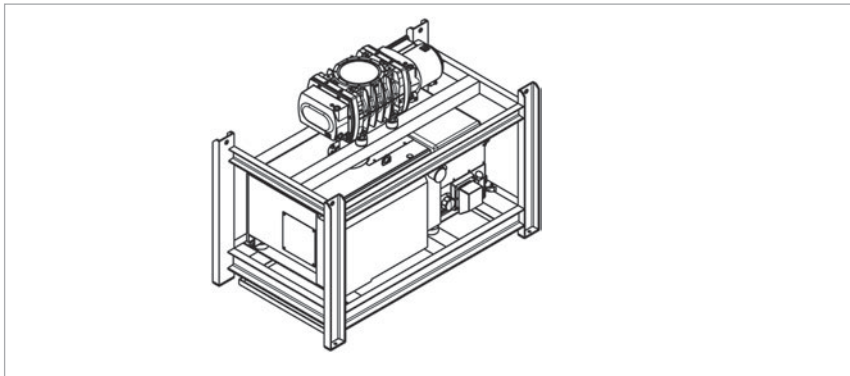

RUTA WH2500/SV630BF/G

Standard Equipment

- RUVAC WH with water cooling
- Exhaust filter with oil return line
- Oil filter
- Oil collecting pan
- Gas ballast valve:
SOGEVAC SV 630 BF 24 V DC
- SOGEVAC SV 630 BF with water cooling
- SOGEVAC SV 1200 with air cooling
- Crane eyes on the frame
- Floor mounting
- The oil is supplied with the pump
- RUVAC WH including external frequency converter (frequency converter permits pumping speed control)
- CE approval

Options

- Frequency converter for controlling the speed of the Roots pump (only RUVAC WA/WS)
- 24 V DC gas ballast valve or manually operated
- Sound proofing box
- Vibration absorbers
- Castors
- Different types of floor mounts
- Oil drain valve on each pump
- Special motors
- Electric control systems

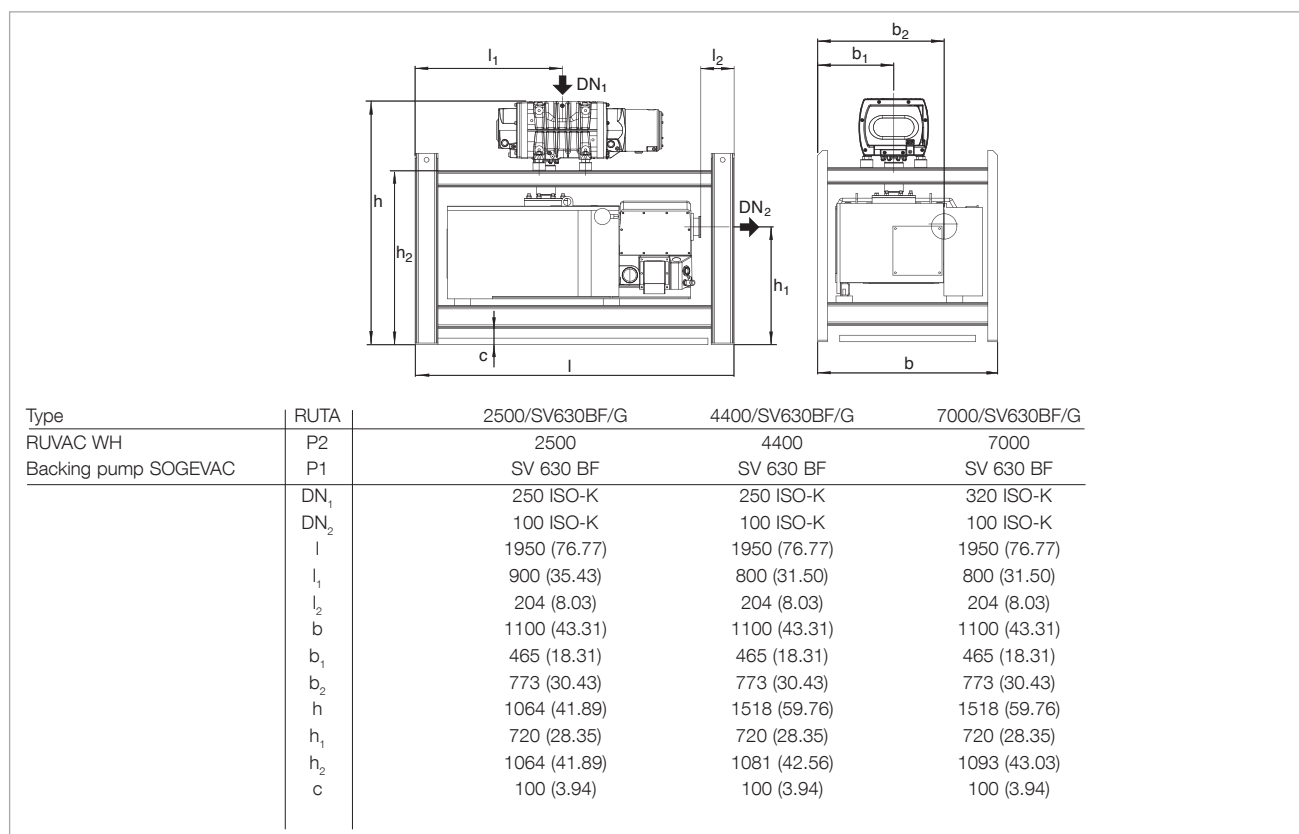

Dimensional drawing for the pump systems with SOGEVAC SV backing pumps

Technical Data, 50 Hz

		RUTA		
		WH 2500/ SV630BF/G	WH 4400/ SV630BF/G	WH 7000/ SV630BF/G
RUVAC WH ¹⁾	P2	2500	4400	7000
Backing pump SOGEVAC	P1	SV 630 BF	SV 630 BF	SV 630 BF
Pumping speed, 50 Hz at 10 ⁻¹ mbar (7.5 x 10 ⁻² Torr)	m ³ x h ⁻¹ (cfm)	1902 (1119)	3332 (1961)	4990 (2937)
Ultimate total pressure with gas ballast	mbar	< 5 x 10 ⁻³	-	-
	(Torr)	(< 3.7 x 10 ⁻³)	-	-
without gas ballast	mbar	-	< 5 x 10 ⁻³	< 5 x 10 ⁻³
	(Torr)	-	(< 3.7 x 10 ⁻³)	(< 3.7 x 10 ⁻³)
Installed motor power 400 V, 50 Hz	kW (hp)	21.5 (28.8)	26.0 (34.9)	26.0 (34.9)
Electrical power consumption at 10 ⁻¹ mbar (7.5 x 10 ⁻² Torr)	kW (hp)	8.5 (11.4)	9.68 (12.98)	9.84 (13.20)
Noise level without gas ballast at 10 ⁻¹ mbar (7.5 x 10 ⁻² Torr)	dB(A)	73	73	73
Oil filling, total, approx.	l (qt)	16.2 (17.1)	27.0 (4.6)	27.0 (4.6)
Weight, total, approx.	kg (lbs)	1360 (2998)	1530 (3373)	1590 (3505)
Connecting flange				
Inlet port	DN ₁	250 ISO-K	250 ISO-K	320 ISO-K
Outlet port	DN ₂	100 ISO-K	100 ISO-K	100 ISO-K

Ordering Information

		RUTA		
		WH 2500/ SV630BF/G	WH 4400/ SV630BF/G	WH 7000/ SV630BF/G
		Part No.	Part No.	Part No.
RUVAC WH ¹⁾	P2	2500	4400	7000
Backing pump SOGEVAC	P1	SV 630 BF	SV 630 BF	SV 630 BF
Pump system, complete (frame version), frame mounted, with Roots vacuum pump RUVAC WH		503161V001 ^{1, 2)}	503161V001 ^{1, 2)}	503161V001 ^{1, 2)}

¹⁾ Including external frequency converter

²⁾ With this combination, continuous operation of the Roots pump is not possible at atmospheric pressure

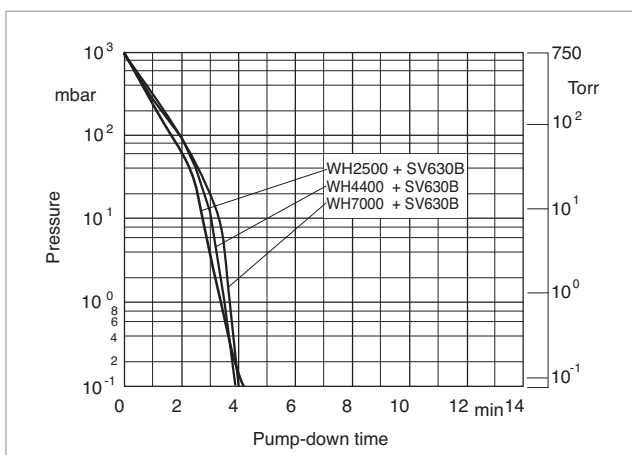

Pump-down time diagram for a 10 m³ tank at 50 Hz

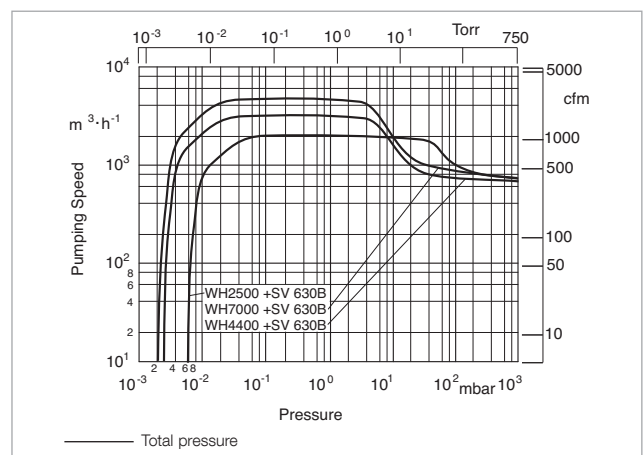

Pumping speed diagram at 50 Hz

Pump Systems (Only available for purchase in North and South America)

RBS - B/BCS Roots Pump Systems with Two-Stage TRIVAC Backing Pumps



RBS - B/BCS Roots pumping system, shown with optional AF exhaust filter

Standard Equipment

- System consists of TRIVAC dual-stage B or BCS direct drive vane pump and RUVAC blower
- Complete air-cooled system
- 18" wide frame base equipped with caster wheels and leveling pads
- Compact construction with quiet operation
- Manual operation of gas ballast
- Close-coupled RUVAC blower with ANSI inlet lange

Options

- All TRIVAC accessories, Exhaust filter, 24 V DC gas ballast valve, chemical oil filter, and electrical limit switch system
- Full frame drip pan
- Oil drain valves
- Special motor voltages and frequencies
- Special oil for unique applications
- Full electrical controls for control start/stop and monitoring of system

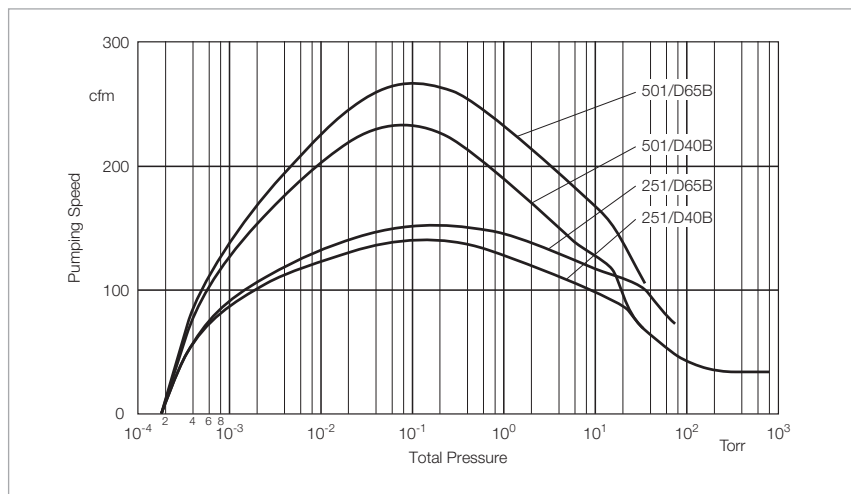

Pumping speed diagram for the RBS systems with WSU series Roots blowers at 60 Hz

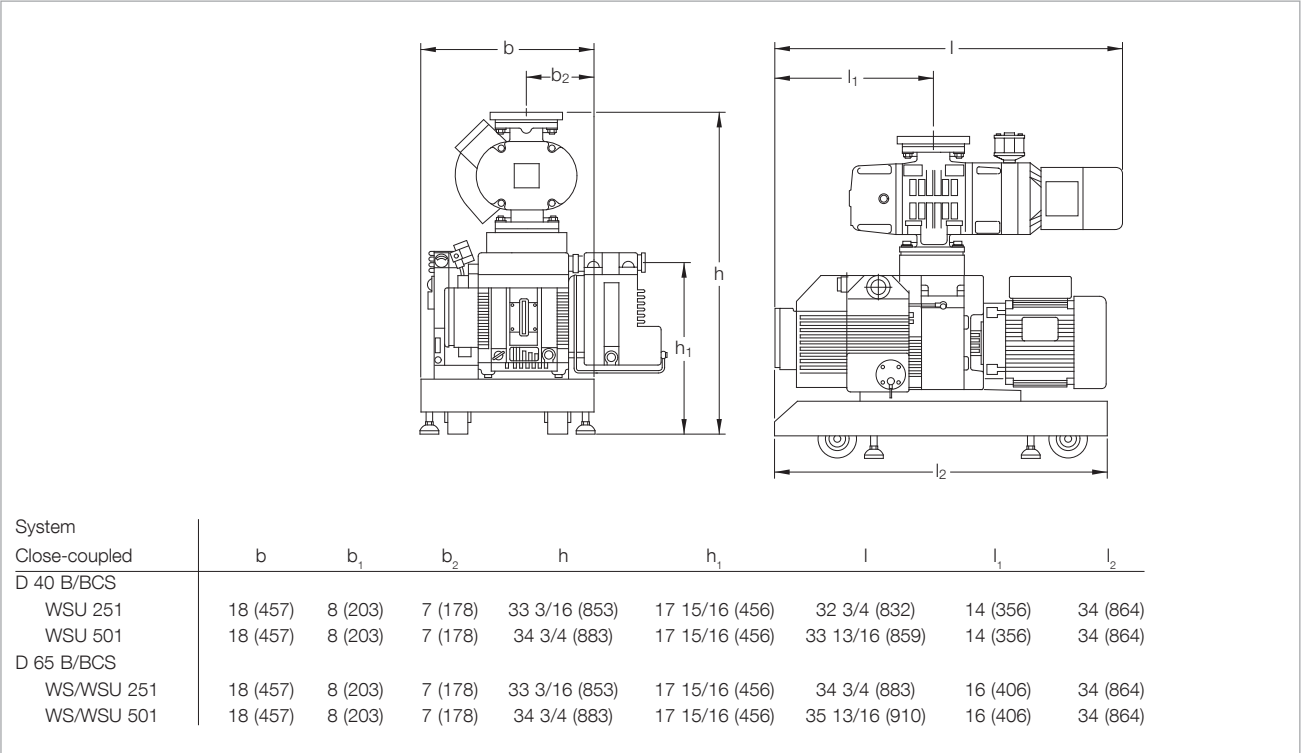

Dimensional drawing for the RBS - B/BCS Roots pumping systems 18" with TRIVAC D 40/65 B backing pumps, close-coupled package; dimensions in brackets () are in mm

Technical Data

RBS - B/BCS Roots Pump Systems

		251/D40B	251/D65B	501/D40B	501/D65B
RUVAC (WA/WAU/WS/WSU possible)		251	251	501	501
TRIVAC backing pump		D 40 B/BCS	D 65 B/BCS	D 40 B/BCS	D 65 B/BCS
Pumping speed @ 0.1 Torr	cfm (m ³ x h ⁻¹)	140 (237)	150 (254)	232 (394)	267 (453)
Ultimate total pressure	Torr (mbar)	2 x 10 ⁻⁴ (< 4 x 10 ⁻⁴)	2 x 10 ⁻⁴ (< 4 x 10 ⁻⁴)	2 x 10 ⁻⁴ (< 4 x 10 ⁻⁴)	2 x 10 ⁻⁴ (< 4 x 10 ⁻⁴)
Connecting flanges					
Inlet port					
WSU	DN	3" ANSI	3" ANSI	3" ANSI	3" ANSI
Outlet port	DN	40 ISO-KF	40 ISO-KF	40 ISO-KF	40 ISO-KF
Operating voltage	V	208/230/460	208/230/460	208/230/460	208/230/460
Phase / Frequency ¹⁾	- / Hz	3 / 60	3 / 60	3 / 60	3 / 60
Full load amps ²⁾					
RUVAC WSU		5.5/5.5/3.2	5.5/5.5/3.2	9.0/9.0/5.2	9.0/9.0/5.2
TRIVAC		9.0/8.8/4.5	9.0/8.8/4.5	9.0/8.8/4.5	9.0/8.8/4.5
Displacement					
RUVAC	cfm (m ³ x h ⁻¹)	179 (304)	179 (304)	357 (606)	357 (606)
TRIVAC	cfm (m ³ x h ⁻¹)	32 (54)	53 (90)	32 (54)	53 (90)
Maximum differential pressure	Torr (mbar)	60 (80)	60 (80)	60 (80)	60 (80)
Normal starting pressure ³⁾	Torr (mbar)	20 (27)	30 (40)	12 (16)	16 (21)
Oil capacity					
RUVAC WSU	qt (l)	0.75 (0.7)	0.75 (0.7)	1.10 (1.0)	1.10 (1.0)
TRIVAC	qt (l)	2.70 (2.6)	3.40 (3.2)	2.70 (2.6)	3.40 (3.2)
Nominal rotation speed					
RUVAC	rpm (min ⁻¹)	3600 (3600)	3600 (3600)	3600 (3600)	3600 (3600)
TRIVAC	rpm (min ⁻¹)	1800 (1800)	1800 (1800)	1800 (1800)	1800 (1800)
Motor power					
RUVAC WSU	hp (kW)	1.9 (1.4)	1.9 (1.4)	3.3 (2.4)	3.3 (2.4)
TRIVAC	hp (kW)	3.0 (2.2)	3.0 (2.2)	3.0 (2.2)	3.0 (2.2)

Ordering Information

RBS - B/BCS Roots Pump Systems

	251/D40B	251/D65B	501/D40B	501/D65B
	Part. No.			
RBS - B/BCS Roots pump system (supplied with hydrocarbon oil)	Ordering Information see right page			

¹⁾ For 50 Hz systems, consult the factory

²⁾ Determined by operating voltage

³⁾ WSU pumps permit start-up at atmospheric pressure (760 Torr)

Ordering Information

Blower / TRIVAC pump

- WSU 251 / D 40 B
- WSU 251 / D 40 BCS-LVO 400
- WSU 251 / D 65 B
- WSU 251 / D 65 B-LVO 400
- WSU 501 / D 40 B
- WSU 501 / D 40 BCS-LVO 400
- WSU 501 / D 65 B
- WSU 501 / D 65 BCS-LVO 400

Reserved

Electrical Control Panel

- None
- 208 V
- 230 V
- 460 V

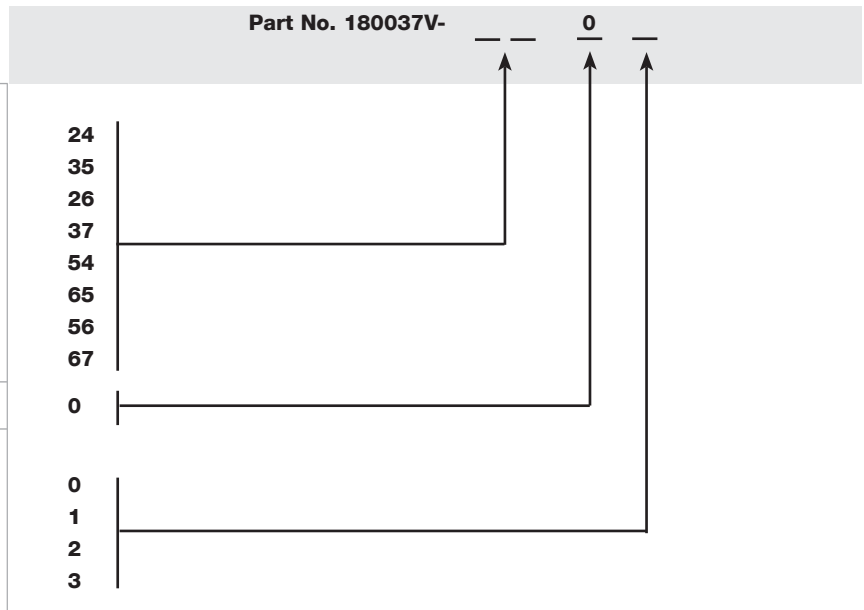

Pump Systems (Only available for purchase in North and South America)

HTS Close-Coupled Systems with Single-Stage SOGEVAC Backing Pumps

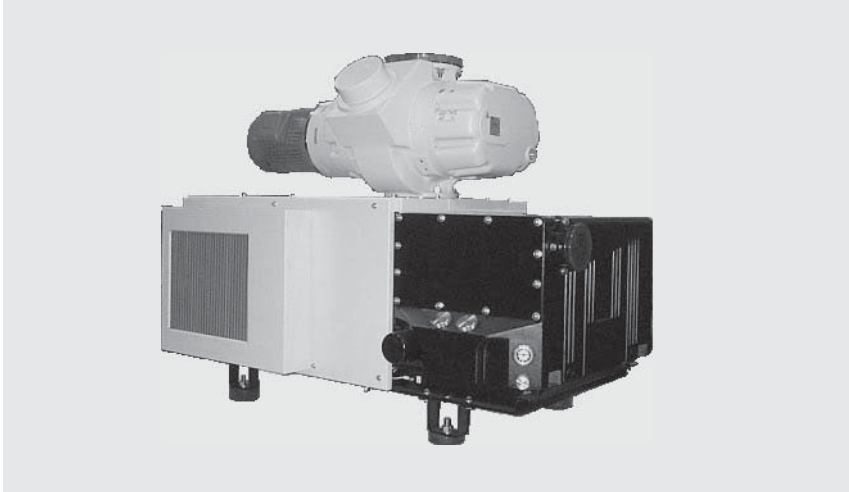

HTS close-coupled system

Standard Equipment

- System consists of single-stage SOGEVAC vane pump
- Complete air-cooled system
- Close-coupled RUVAC blower
- Compact construction with quiet operation
- Manual operation of gas ballast
- Spin-on type oil filter

Options

- SOGEVAC accessories: oil level monitoring, exhaust case gauge, 24 V DC gas ballast purge, water cooling
- Frame base mounted caster wheels
- Frame base mounted leveling pads
- Oil drain valves
- Inlet dust filter
- Special motor voltages and frequencies
- Special oil for unique applications
- Full NEMA12 electrical controls for stand/stop operation and monitoring of system from remote and local locations
- 24 V DC gas ballast valve

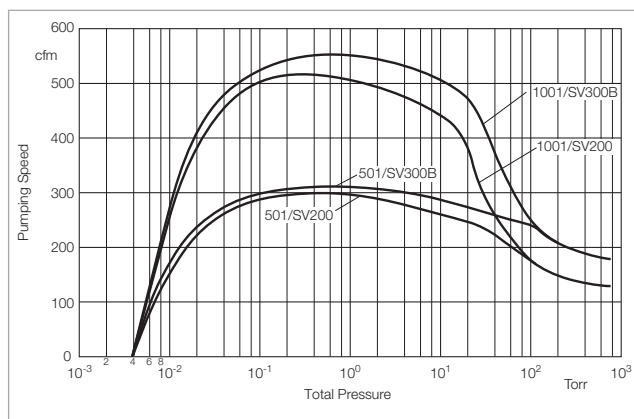

Pumping speed diagram for the HTS close-coupled systems with WSU series Roots blowers and SOGEVAC SV 200/300B at 60 Hz

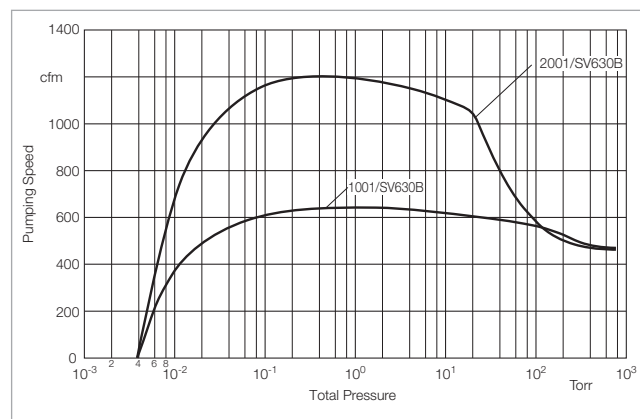

Pumping speed diagram for the HTS close-coupled systems with WSU series Roots blowers and SOGEVAC SV 630B at 60 Hz

Dimensions for SV 200 and SV 300 B only

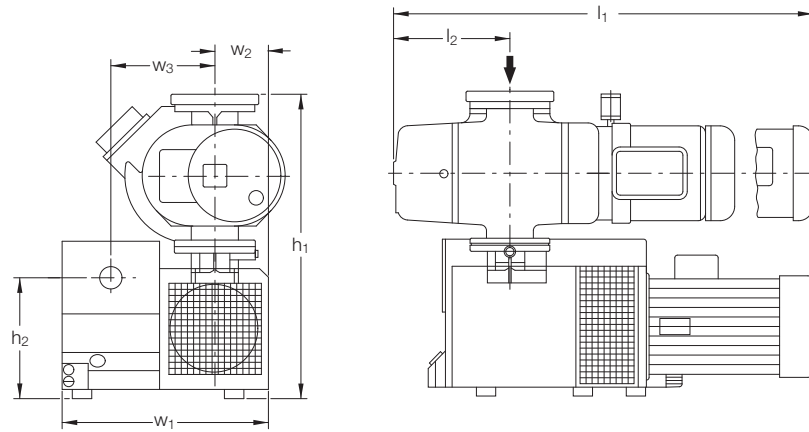

Dimensions for SV 630 B only

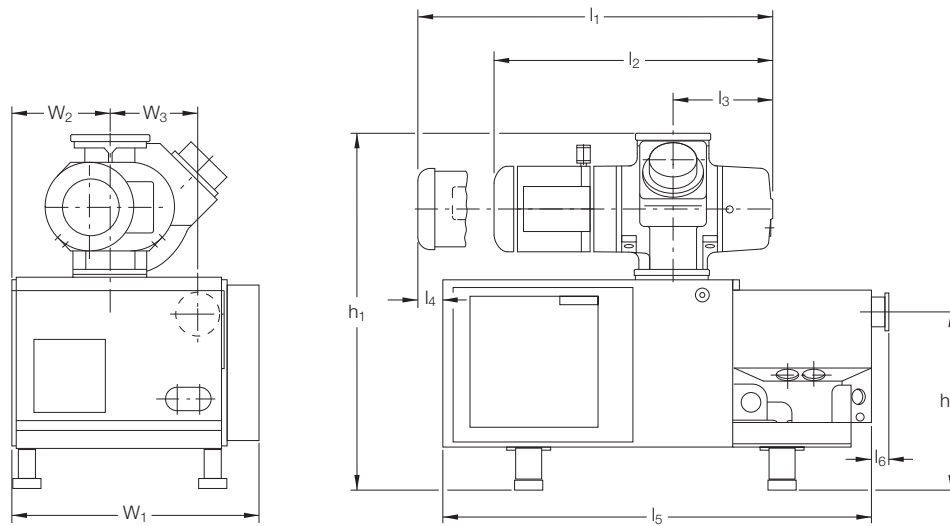

Roots Pump	Vane Pump	h_1	h_2	l_1	l_2	l_3	l_5	l_6	w_1	w_2	w_3
WSU 501	SV 200	29 7/16 (748)	12 17/32 (318)	-	9 17/32 (242)	-	-	-	21 11/16 (551)	6 1/8 (156)	10 19/32 (269)
WSU 501	SV 300 B	29 7/16 (748)	12 17/32 (318)	-	9 17/32 (242)	-	-	-	21 11/16 (551)	6 1/8 (156)	10 19/32 (269)
WSU 1001	SV 200	31 7/16 (799)	12 17/32 (318)	-	11 15/16 (303)	-	-	-	21 1/16 (535)	5 1/2 (140)	10 19/32 (269)
WSU 1001	SV 300 B	31 7/16 (799)	12 17/32 (318)	-	11 15/16 (303)	-	-	-	22 13/16 (579)	7 1/4 (184)	10 19/32 (269)
WSU 2001	SV 630 B	48 5/16 (1227)	23 13/16 (605)	50 3/16 (1275)	-	14 9/16 (370)	60 3/4 (1543)	2 1/2 (64)	34 15/16 (887)	13 7/8 (352)	12 13/32 (315)

Dimensional drawing for the HTS close-coupled system with single-stage SOGEVAC backing pumps; dimensions in brackets () are in mm

Technical Data

HTS Close-Coupled Systems

		501/SV200	501/SV300B	1001/SV200	1001/SV300B
RUVAC		WSU 501	WSU 501	WSU 1001	WSU 1001
SOGEVAC		SV 200	SV 300 B	SV 200	SV 300 B
Pumping speed @ 0.1 Torr	cfm (m ³ x h ⁻¹)	277 (470)	285 (483)	504 (855)	545 (925)
Ultimate total pressure	Torr (mbar)	< 8 x 10 ⁻³ (< 1 x 10 ⁻²)	< 8 x 10 ⁻³ (< 1 x 10 ⁻²)	< 8 x 10 ⁻³ (< 1 x 10 ⁻²)	< 8 x 10 ⁻³ (< 1 x 10 ⁻²)
Connecting flanges					
Inlet port WSU	DN	3" ANSI	3" ANSI	4" ANSI	4" ANSI
Exhaust port SOGEVAC	DN	2" NPT	2" NPT	2" NPT	2" NPT
Operating voltage	V	208/230/460	208/230/460	208/230/460	208/230/460
Phase / Frequency ¹⁾	- / Hz	3 / 60	3 / 60	3 / 60	3 / 60
Full load amps ²⁾					
RUVAC WSU		7.8/10.0/5.8	7.8/10.0/5.8	13.0/14.7/8.5	13.0/14.7/8.5
SOGEVAC		21.0/18.0/9.0	29.0/25.0/12.5	21.0/18.0/9.0	29.0/25.0/12.5
Displacement					
RUVAC	cfm (m ³ x h ⁻¹)	357 (606)	357 (606)	707 (1200)	707 (1200)
SOGEVAC	cfm (m ³ x h ⁻¹)	130 (606)	200 (340)	130 (606)	200 (340)
Oil capacity					
RUVAC WSU	qt (l)	1.10 (1.00)	1.10 (1.00)	2.10 (2.00)	2.10 (2.00)
SOGEVAC	qt (l)	5.30 (5.00)	9.00 (8.50)	5.30 (5.00)	9.00 (8.50)
Nominal rotation speed					
RUVAC WAU/WSU	rpm (min ⁻¹)	3600 (3600)	3600 (3600)	3600 (3600)	3600 (3600)
SOGEVAC	rpm (min ⁻¹)	1800 (1800)	1800 (1800)	1800 (1800)	1800 (1800)
Motor power					
RUVAC WSU	hp (kW)	3.3 (2.4)	3.3 (2.4)	6.0 (4.4)	6.0 (4.4)
SOGEVAC	hp (kW)	7.5 (5.5)	10.0 (7.4)	7.5 (5.5)	10.0 (7.4)

Ordering Information

HTS Close-Coupled Systems

		501/SV200	501/SV300B	1001/SV200	1001/SV300B
		Part. No.			
HTS - close-coupled systems		Ordering Information see right page			

¹⁾ For 50 Hz systems, consult the factory

²⁾ Determined by operating voltage

Technical Data

HTS Close-Coupled Systems

1001/SV630B

2001/SV630B

RUVAC		1001	2001
SOGEVAC		SV 630 B	SV 630 B
Pumping speed @ 0.1 Torr	cfm (m ³ x h ⁻¹)	610 (1035)	1186 (2031)
Ultimate total pressure	Torr (mbar)	< 8 x 10 ⁻³ (< 1 x 10 ⁻²)	< 8 x 10 ⁻³ (< 1 x 10 ⁻²)
Connecting flanges			
Inlet port WSU	DN	4" ANSI	6" ANSI
Outlet port	DN	4" ANSI	4" ANSI
Operating voltage	V	460	460
Phase / Frequency ¹⁾	- / Hz	3 / 60	3 / 60
Full load amps ²⁾			
RUVAC WSU		8.5	5.0
SOGEVAC		29.5	29.5
Displacement			
RUVAC	cfm (m ³ x h ⁻¹)	707 (1200)	1449 (2460)
SOGEVAC	cfm (m ³ x h ⁻¹)	495 (840)	495 (840)
Oil capacity			
RUVAC WSU	qt (l)	2.10 (2.0)	4.20 (4.0)
SOGEVAC	qt (l)	37.0 (35.0)	37.0 (35.0)
Nominal rotation speed			
RUVAC WSU	rpm (min ⁻¹)	3600 (3600)	3600 (3600)
SOGEVAC	rpm (min ⁻¹)	1170 (1170)	1170 (1170)
Motor power			
RUVAC WSU	hp (kW)	6.1 (4.5)	11.4 (8.4)
SOGEVAC	hp (kW)	25.0 (13.4)	25.0 (13.4)

Ordering Information

	Part No. 180036V-
Blower / TRIVAC pump WSU 501 / SV 200 WSU 501 / SV 300 B WSU 1001 / SV 200 WSU 1001 / SV 300 B WSU 1001 / SV 630 B WSU 2001 / SV 630 B	52 53 12 13 16 26
Casters & Levelers (SV 200 & SV 300 only) None Casters & Levelers Casters only Levelers only	0 1 2 3
Electrical Control Panel None 208 V (SV 200 & SV 300 only) 230 V (SV 200 & SV 300 only) 460 V	0 1 2 3

Central Vacuum Supply Systems with SOGEVAC Pumps

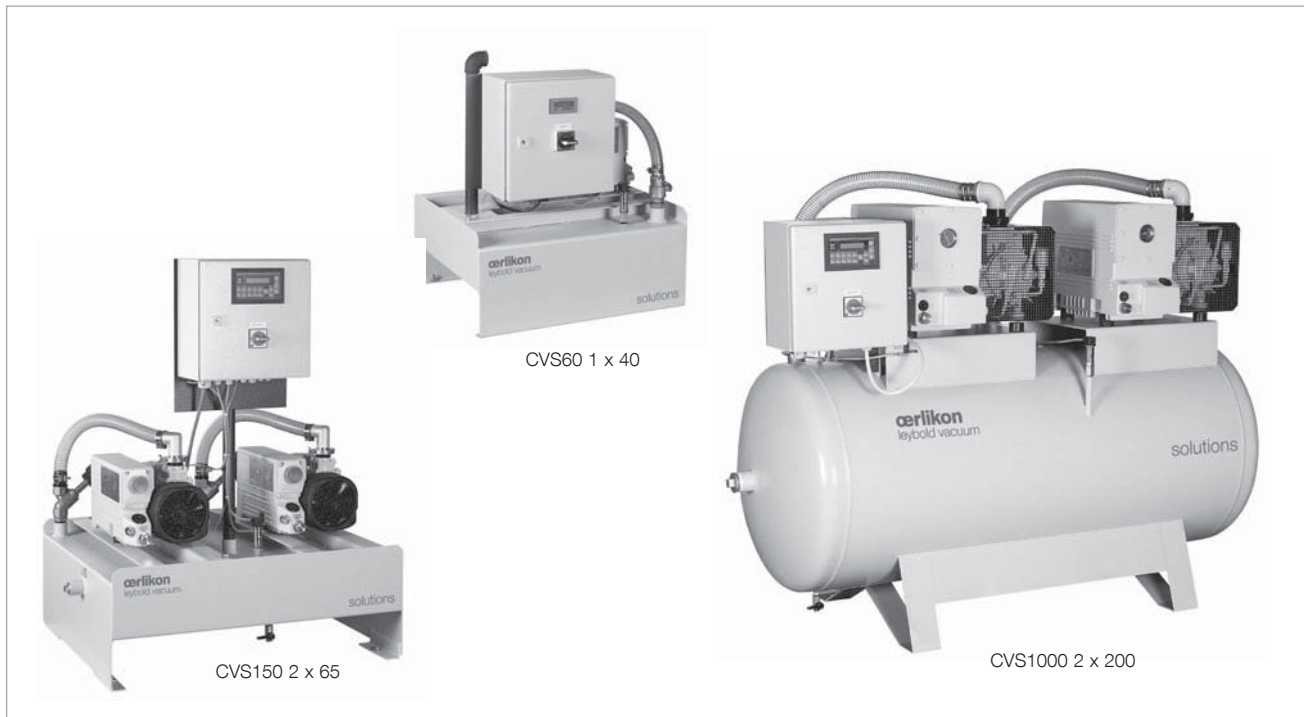

Pictures of various central vacuum supply systems (the right of technical changes is reserved)

Central vacuum supply systems are frequently used in those cases where a large number of minor requirements for vacuum need to be economically covered. Moreover, the systems serve the purpose of compensating for large variations in the number of vacuum consumers and increase the availability of the vacuum service.

A typical central vacuum supply system from Oerlikon Leybold Vacuum consists chiefly of one or more SOGEVAC rotary vane vacuum pumps, a buffer vessel, an electrical cabinet with controller as well as the corresponding connection components. The systems are supplied by us fully assembled, tested as plug and play units.

Technical Data and Ordering Information

Designation	Vessel volume (l)	Nominal pumping speed (m ³ x h ⁻¹)	Connection (G or NPT)	Electrical power rating ¹⁾ (kW)	Type of controller	Part No.
CVS60 1 x 25	60	25	1 1/4"	0.8	BASIC	501 792
CVS60 1 x 40	60	40	1 1/4"	1.1	BASIC	501 793
CVS60 1 x 65	60	65	1 1/4"	1.5	BASIC	501 796
CVS150 1 x 40	150	40	1 1/4"	1.1	BASIC	501 800
CVS150 1 x 65	150	65	1 1/4"	1.5	BASIC	501 803
CVS300 1 x 40	300	40	2"	1.1	BASIC	501 820
CVS300 1 x 65	300	65	2"	1.5	BASIC	501 823
CVS300 1 x 100	300	100	2"	2.5	BASIC	501 826
CVS300 2 x 65	300	130	2"	3.0	FF	501 832
CVS300 2 x 100	300	200	2"	5.0	FF	501 835
CVS500 1 x 100	500	100	2"	2.5	BASIC	501 846
CVS500 1 x 200	500	200	2"	4.0	FF	501 849
CVS500 1 x 300B	500	280	2"	5.5	FF	503 174 V001
CVS500 2 x 40	500	80	2"	2.2	FF	501 855
CVS500 2 x 65	500	130	2"	3.0	FF	501 858
CVS500 2 x 100	500	200	2"	5.0	FF	501 861
CVS500 2 x 200	500	360	2"	8.0	FF	501 864
CVS1000 2 x 100	1000	200	2"	5.0	FF	501 879
CVS1000 2 x 200	1000	360	2"	8.0	FF	501 882
CVS1000 2 x 300B	1000	560	2"	11.0	FF	503 175 V001

¹⁾ At a mains voltage of 400 V / 50 Hz, 3-ph.

Beyond the equipment which is supplied as standard (see list), the modular design of the central vacuum supply systems from Oerlikon Leybold Vacuum allows for customization according to your specific requirements.

Optionally available are, for example:

- Higher pumping speeds and larger buffer volumes
- Electropneumatic or solenoid blocking valves
- Mobile construction on castors
- Other mains voltages
- Additional pumps, filters, fittings etc.

Controller Types for the Central Vacuum Supply Systems from Oerlikon Leybold Vacuum

Generally a difference is made between the controller types **BASIC** and **FF** (Full Featured).

Differing custom solutions are available upon request.

BASIC Controller

The Basic controller provides for two freely selectable switching thresholds, through which an individual vacuum pump or alternatively a blocking valve (optional) can be driven.

Moreover, the controller includes an electronic pressure display and an operating hours counter.

This type of controller is suited for systems equipped with a single pump up to a nominal pumping speed of 100 m³/h (58.9 cfm).

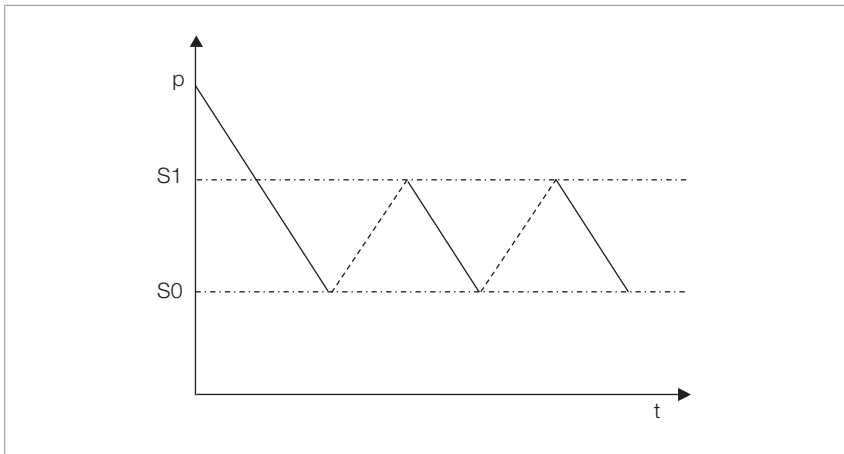

Basic control with one pump

Operating Principle of the BASIC Controller

Starting at atmospheric pressure, the central vacuum supply system is evacuated down to the intended “lower operating pressure” S0. As soon as the pressure has attained the level of S0, the vacuum pump is switched off automatically, respectively the optional blocking valve is closed.

When switching on the consumers, the pressure in the system rises again until the “upper operating pressure” is reached thereby tripping the switch-on threshold S1 of the pump, respectively attaining the opening pressure of the valve.

Provided pumping speed of the pump and vacuum consumption are balanced, the operating pressure will change between S0 and S1. At reduced consumption, the system pressure will reduce until the switching threshold S0 is reached again causing the pump to switch off, respectively the valve to close etc.

FF Controller

Basically the FF controller provides for four freely selectable switching thresholds and has thus been designed to operate two pumps running in parallel. Depending on the design rating and current demand, the base load or master pump will operate alone or jointly together with the spare pump.

In order to spread the number of operating hours equally between the pumps, master pump and spare pump are interchanged in regular intervals. In case a pump fails, the controller effects an automatic change to the spare pump.

For operating vacuum pumps having a nominal pumping speed of over

100 m³/h (58.9 cfm), a delayed shut-down facility has been integrated which will restrict the number of switching cycles to 6 per hour.

Through the use of a Programmable Logic Controller (PLC), the FF controller permits flexible coverage of quite differing requirements.

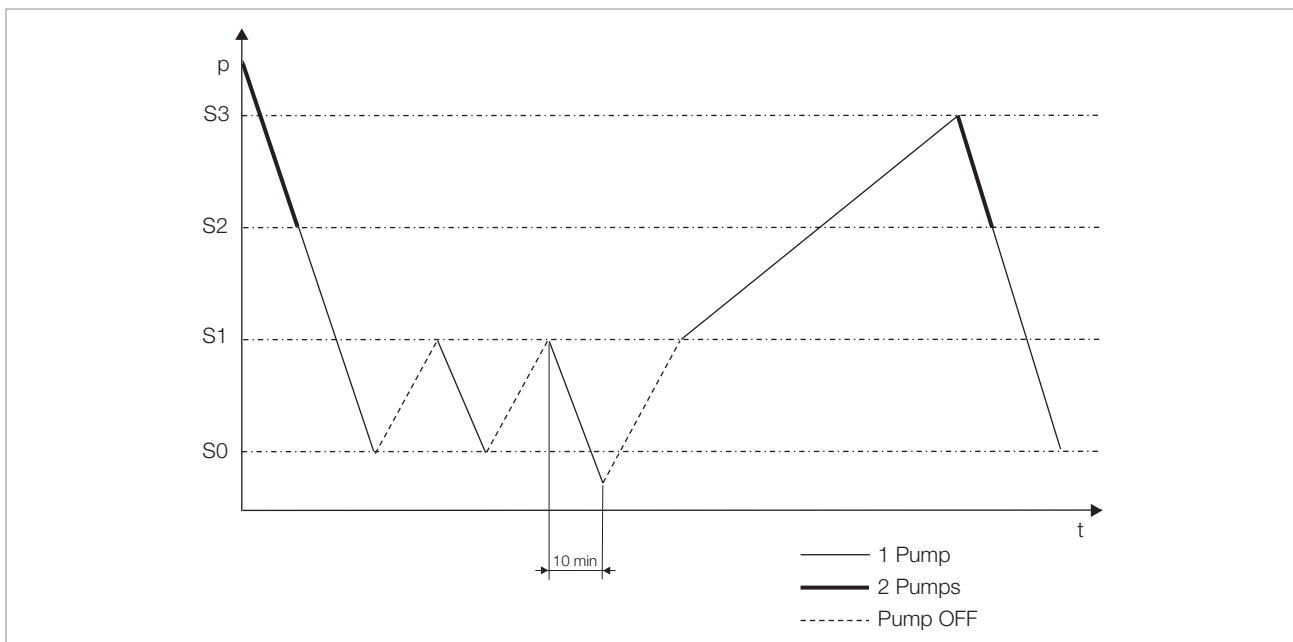

FF controller with two pumps and an example for delayed shutdown (pumps over 100 m³/h (58.9 cfm))

Operating Principle of the FF Controller

Just as for the Basic controller, the system is, upon switching on, evacuated down to the lower operating pressure S0. This is effected with both pumps running in parallel (master pump and spare pump) until the shutdown threshold for the spare pump S2 is reached. Thereafter, the master pump alone will ensure that the lower operating pressure is reached and is then also switched off. When the system pressure increases due to the number of consumers or leaks to the level of S1, then the master pump will be switched on automatically etc.

In the case of vacuum pumps having a pumping speed of over 100 m³/h (58.9 cfm) and a running time of the pump of less than 10 minutes, then the standard switch off delay can be responsible for the pressure to drop below S0. This will prevent too frequent switching on and off of the pumps.

If for process reasons the pressure is not allowed to drop below the lower operating pressure, we recommend

the use of electropneumatic or solenoid blocking valves.

If the current vacuum demand cannot be met by the master pump alone, the system pressure will increase to the upper switching pressure S3 upon which the spare pump is automatically started.

With both pumps running in parallel, the system is then again evacuated until the switch off threshold S2 for the spare pump is reached again etc.

Only available for purchase in North and South America

Central Vacuum Supply Systems

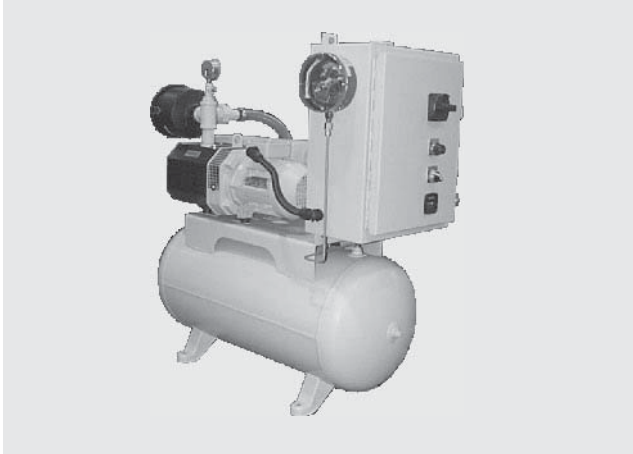

Central vacuum supply system, simplex

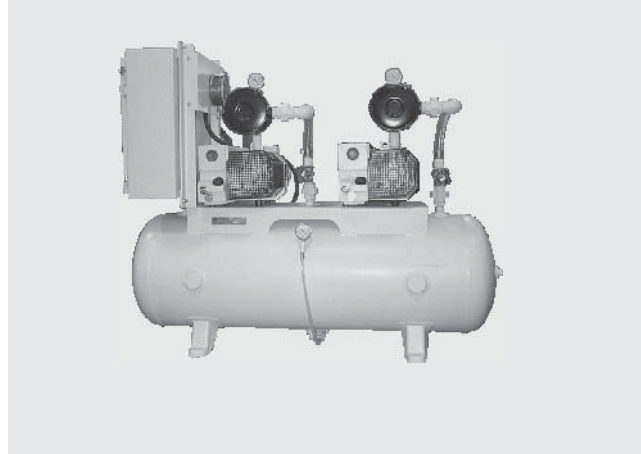

Central vacuum supply system, duplex

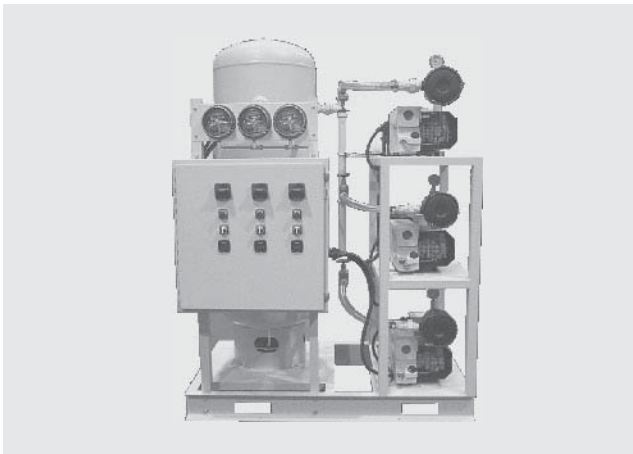

Central vacuum system, triplex

Standard Equipment

- ASME® rated receiver tank
- Flexible configurations for one, two, or three SOGEVAC pumps
- Manual isolation valves
- Simple operation, high reliability, easy maintenance
- Complete package with gauges and NEMA12 controls
- Standard "ON/OFF/AUTO" switch
- Elapsed time meters
- Inlet particulate filters
- Lead/Lag or continuous operation of pumps
- Adjustable pressure switch for control of vacuum level
- Air-cooled SOGEVAC pumps with built-in "anti-suckback" valves

Options

- Tank or stack mounted pumps
- Larger receiver tank
- Special inlet filters
- Automatic isolation valves
- Special design controls per customer specification

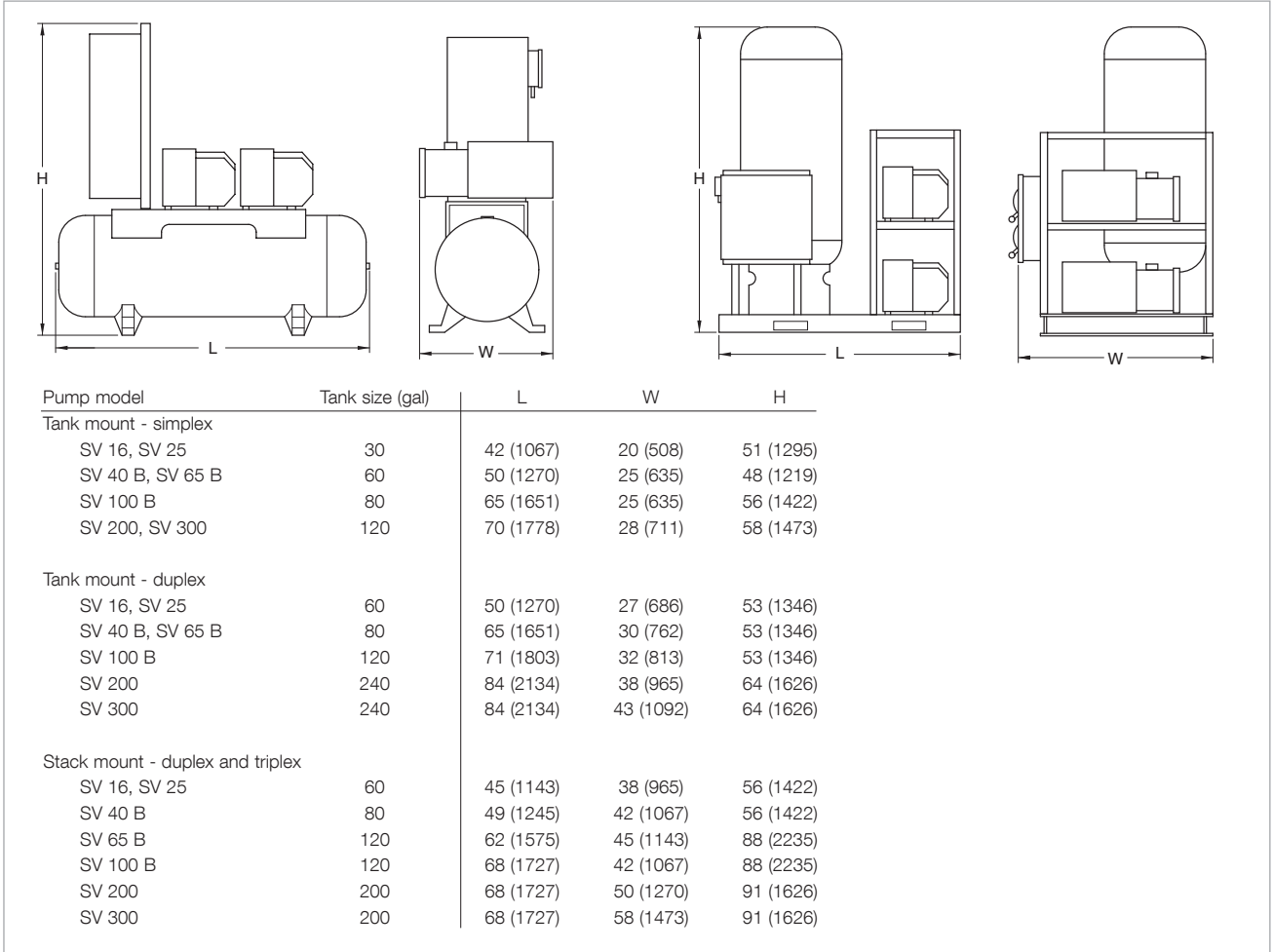

Central vacuum supply systems, tank mounted [left] and stack mounted [right]; dimensions in inch, dimensions in brackets () are in mm

Technical Data

Performance Characteristics

		SV 16	SV 25	SV 40 B	SV 65 B	SV 100 B	SV 200	SV 300
Free air displacement	cfm (m ³ x h ⁻¹)	11 (18.6)	17.0 (29.0)	31.2 (53.0)	41.8 (71.0)	68.9 (117.0)	129.5 (219.8)	200.3 (340.0)
Actual pumping speed	cfm (m ³ x h ⁻¹)	10 (16.9)	15 (25.5)	27.7 (47.0)	37.7 (64.0)	61.8 (105.0)	117.8 (200.0)	170.8 (289.9)
Guaranteed base pressure	Torr	0.4	0.4	0.4	0.4	0.4	0.06	0.06
Base pressure with gas ballast	Torr	1.1	1.1	1.1	1.1	1.0	0.5	0.5
Water vapor tolerance	Torr	30.0	30.0	22.5	22.5	22.5	30.0	30.0
Water vapor pumping with gas ballast	qt/hr	0.32	0.48	0.95	1.32	1.8	5.7	7.8
Noise level at 3 feet with 1 pump running without gas ballast	dB(A)	56	56	63	64	64	73	74
Motor	hp	1.0	1.5	2.0	2.5	4.0	7.5	10.0
Pump rotational speed	rpm	1750	1500	1750	1750	1750	1750	1750
Oil capacity	qt	2.0	2.0	1.05	2.1	2.1	5.5	9.0
Inlet / exhaust - NPT	in.	1/2 / 1/2	1/2 / 1/2	1-1/4 / 1-1/4	1-1/4 / 1-1/4	1-1/4 / 1-1/4	2 / 2	2 / 2
Pump weight	lbs	50.7	52.9	99.3	114.8	194.3	341.8	430.0

Technical Data

	Tank size (gal)	Tank Mount	Tank Mount	Stack Mount
		Simplex	Duplex	Duplex and Simplex
SV 16, SV 25	Tank size (gal)	30	60	60
SV 40 B	Tank size (gal)	60	80	80
SV 65 B	Tank size (gal)	60	120	120
SV 100 B	Tank size (gal)	80	120	120
SV 200	Tank size (gal)	120	240	200
SV 300	Tank size (gal)	120	240	200

Ordering Information

	Part No.	C	-						XX	
System										
Simplex	S									
Duplex	D									
Triplex	T									
Pumps										
SV 16 (1 hp)	016									
SV 25 (1.5 hp)	025									
SV 40 B (2.5 hp)	040									
SV 65 B (3 hp)	065									
SV 100 B (4 hp)	100									
SV 200 (7.5 hp)	200									
SV 300 (10 hp)	300									
Mounting										
Tank mount	T									
Stack mount	S									
Voltage										
460/3/60	A									
230/3/60	B									
230/1/60 (available for SV 16/SV 25 only)	C									
208/3/60 (available for SV 25 only)	D									
115/1/60 (available for SV 16 only)	E									
Duty										
Continuous	C									
Demand Start/Stop	D									

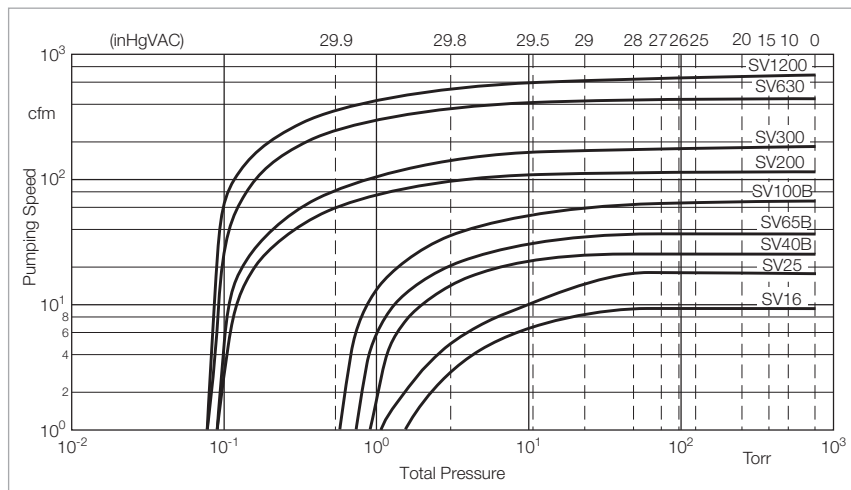

Pumping speed characteristics for the central vacuum supply systems at 60 Hz

Only available for purchase in North and South America

Tank Mounted Medical Vacuum Systems

NFPA 99C compliant and designed for use in medical applications - hospitals, out-patient surgical and other medical facilities



Tank mounted medical vacuum system

Oerlikon Leybold Vacuum tank mounted systems are completely assembled with interconnecting piping, are factory tested and leak-checked prior to shipment.

Some items may be disassembled for protection during shipment.

Required mechanical re-assembly requirements will be clearly noted, as well as needed electrical connections, and are the responsibility of the installer.

System Features

Key features for these duplex systems include two SOGEVAC series oil sealed rotary vane vacuum pumps with displacements up to 69 cfm each, an ultimate vacuum of better than 29.95" Hg, and automatic oil recirculation system with integral coalescing exhaust demisters as standard. ASME rated receiver tanks, NEMA12 / UL listed electrical enclosure and inter-connecting hardware. Each turn-key system is fully assembled and tested at Oerlikon Leybold Vacuum's factory and includes an operation manual and 12 month warranty.

Other System Features

Vacuum pumps and systems:

- Direct-coupled TEFC, IP 55 rated motors
- Integral gas ballast
- Anti suck back valve
- Air-cooled design
- NPT type inlet and exhaust connections
- Inlet protection
 - particulate filters rated for 10 micron retention
 - Isolation ball valves
 - Pump check valves
- Vacuum gauge, 0 - 30" Hg
- Vertical receiver, ASME coded, manual drain valve and tank bypass

Local duplex motor control center:

- 2x magnetic motor starters with overload protection
- Main fused disconnect switch
- 2x through the door disconnect switches
- 2x individual control transformers
- 2x elapsed time meters
- 2x hand-off-auto switches
- Lag pump audible alarm with indicator light
- Automatic alternation
 - Lead / Lag operation
- 2x dual set-point vacuum switches
- Emergency stop
- NEMA12, UL listed enclosure
- System wired for either 208/230/460 V, 3 phase, 60 Hz operation

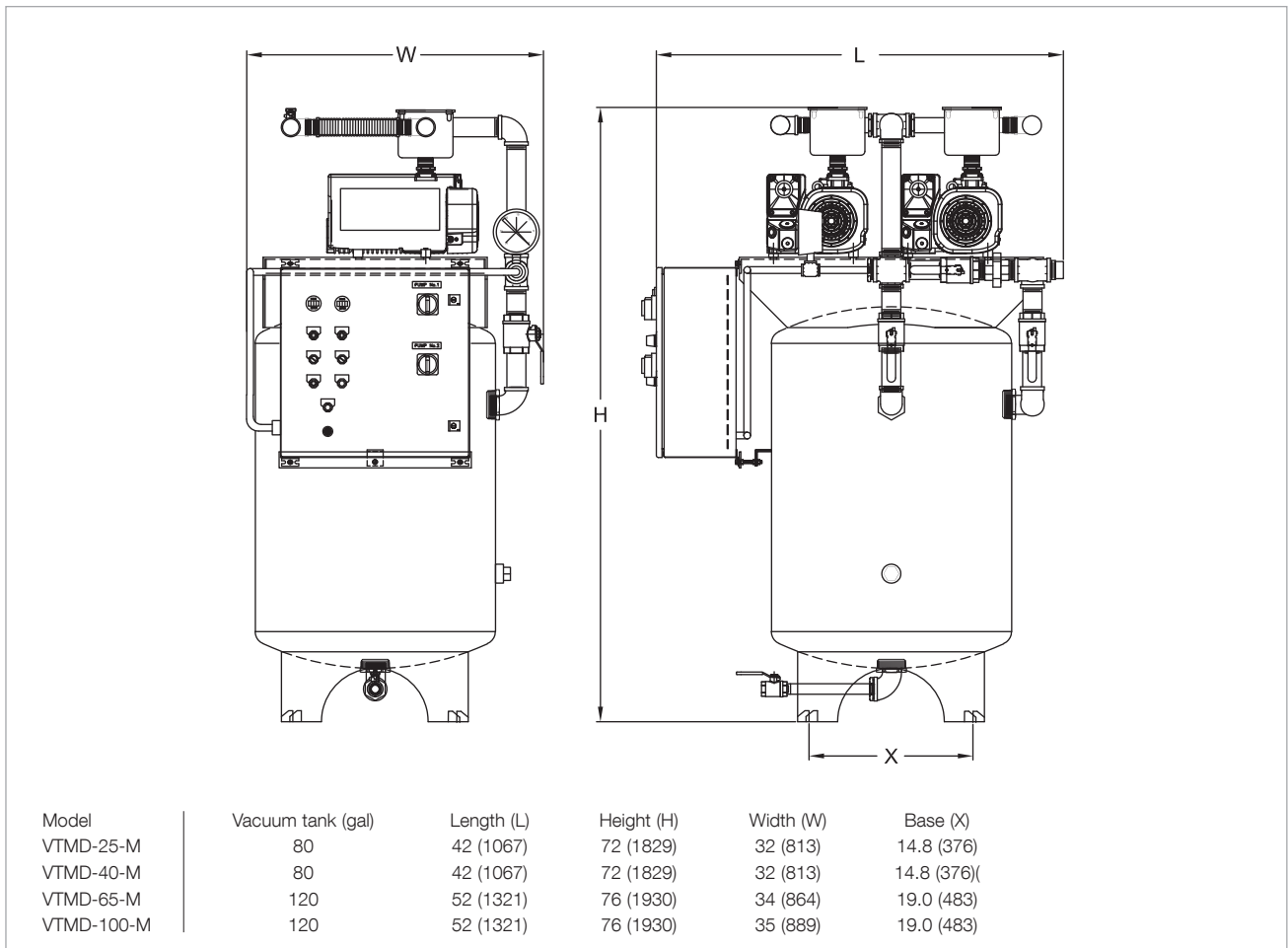

Tank mounted medical vacuum systems; dimensions in inch, dimensions in brackets () are in mm

Technical Data

VTMD-25-M

VTMD-40-M

VTMD-65-M

VTMD-100-M

		VTMD-25-M	VTMD-40-M	VTMD-65-M	VTMD-100-M
Displacement (per pump)	cfm	18.3	31.2	41.8	69.0
Capacity 19" HG (VAC) (per pump)	scfm	6.7	11.4	15.3	25.1
Motor (per pump)	hp (W)	1.5 (2.0)	2.0 (2.7)	3.0 (4.1)	5.0 (6.8)
Vacuum tank	gal	80	80	120	120
Vacuum inlet	NPT	1.5"	1.5"	1.5"	1.5"
Vacuum outlet ¹⁾	NPT	1.25"	1.25"	1.25"	1.25"
Weight	lbs (kg)	700 (305)	750 (340)	1125 (510)	1300 (589)

Ordering Information

VTMD-25-M

VTMD-40-M

VTMD-65-M

VTMD-100-M

	Part. No.	Part. No.	Part. No.	Part. No.
Tank mounted medical vacuum system				
208 V, 3 phase, 60 Hz	S 170 530	S 170 533	S 170 499	S 170 490
230 V, 3 phase, 60 Hz	S 170 531	S 170 534	S 170 536	S 170 538
460 V, 3 phase, 60 Hz	S 170 532	S 170 535	S 170 537	S 170 539

¹⁾ System consists of two outlet flanges

Dry Compressing Vacuum Pump System RUTA with SCREWLINE Backing Pump, Adaptor Version, without palette

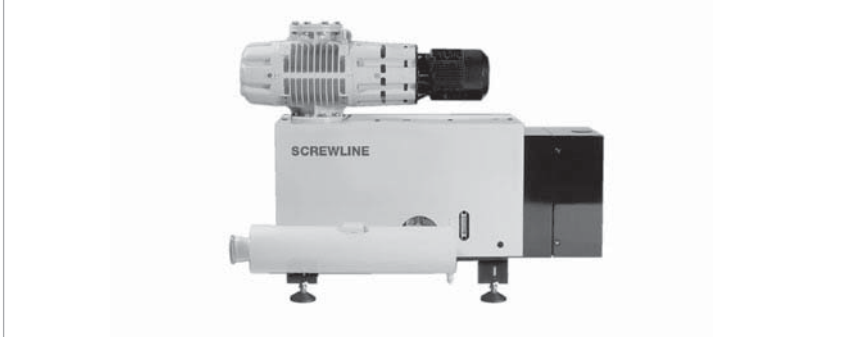

RUTA WAU2001/SP630/A

Standard Equipment

- RUVAC WAU with air cooling
- RUVAC WH with water cooling
- Silencer
- SP-GUARD
- Manually operated gas ballast
- Gear oil collecting pan integrated within the screw pump
- Gear oil supplied with the pump
- Screw pump SCREWLINE SP 630 F with water cooling
- Screw pump SCREWLINE SP 250 with air cooling
- RUVAC WH including external frequency converter (frequency converter permits pumping speed control)
- CE approval
- Condensate drain valve at the silencer
- Sound proofing box
- Vibration absorbers
- Castors
- Different types of floor mounts
- Oil drain valve on each pump
- Electric control systems
- Non-return valve
- Screw pump SCREWLINE SP 630 with air cooling

Options

- Frequency converter for controlling the speed of the Roots pump (only RUVAC WA/WS)

Type	RUTA	501/SP250/A	1001/SP250/A	2001/SP630F/A	700/SP250/A
RUVAC WA/WAU/WS/WSU	P2	501	1001	2001	-
RUVAC WH	P2	-	-	-	700
Backing pump SCREWLINE	P1	SP 250	SP 250	SP 630 F	SP 250
	DN ₁	63 ISO-K	100 ISO-K	160 ISO-K	100 ISO-K
	DN ₂	63 ISO-K	63 ISO-K	100 ISO-K	63 ISO-K
	l	1350 (53.15)	1409 (55.47)	1804 (71.02)	1350 (53.15)
	l ₁	239 (9.41)	298 (11.73)	367 (14.45)	258 (10.16)
	l ₂	533 (20.98)	592 (23.31)	882 (34.72)	552 (21.73)
	l ₃	160 (6.30)	219 (8.62)	336 (13.23)	179 (7.05)
	l ₄	880 (34.65)	880 (34.65)	880 (34.65)	880 (34.65)
	b	761 (29.96)	828 (32.60)	1059 (41.69)	648 (25.51)
	b ₁	260 (10.24)	306 (12.05)	403 (15.87)	260 (10.24)
	b ₂	438 (17.24)	438 (17.24)	546 (21.50)	438 (17.24)
	b ₄	783 (30.83)	783 (30.83)	783 (30.83)	783 (30.83)
	b ₅	470 (18.50)	470 (18.50)	470 (18.50)	470 (18.50)
	h	1213 (47.76)	1239 (48.78)	1342 (52.84)	1158 (45.59)
	h ₁	954 (37.56)	954 (37.56)	1221 (48.07)	949 (37.36)

Dimensional drawing of the pump systems with dry compressing SCREWLINE SP backing pump, adaptor version, without palette. Left with WAU pumps, right with WH pump. Dimensions in brackets () are in inch

Technical Data, 50 Hz

RUTA

		WAU 501/SP250/A	WAU 1001/SP250/A	WAU 2001/SP630(F)/A	WH 700/SP250/A
RUVAC (WA/WAU/WS/WSU possible)	P2	501	1001	2001	–
RUVAC WH	P2	–	–	–	700
Backing pump SCREWLINE	P1	SP 250	SP 250	SP 630 (F)	SP 250
Pumping speed, 50 Hz at 10^{-1} mbar (7.5×10^{-2} Torr)	$\text{m}^3 \times \text{h}^{-1}$ (cfm)	445.0 (262.1)	830.0 (488.9)	1745.0 (1027.8)	635 (374)
Ultimate total pressure without gas ballast	mbar (Torr)	$< 1 \times 10^{-3}$ ($< 7.5 \times 10^{-4}$)	$< 1 \times 10^{-3}$ ($< 7.5 \times 10^{-4}$)	$< 1 \times 10^{-3}$ ($< 7.5 \times 10^{-4}$)	$< 1 \times 10^{-3}$ ($< 7.5 \times 10^{-4}$)
Installed motor power 400 V, 50 Hz	kW (hp)	9.7 (13.0)	11.5 (15.6)	22.5 (30.6)	9.7 (13.0)
Electrical power consumption at 10^{-1} mbar (7.5×10^{-2} Torr)	kW (hp)	6.3 (8.6)	6.7 (9.1)	12.0 (16.3)	6.6 (8.9)
Noise level with silencer at 10^{-1} mbar (7.5×10^{-2} Torr)	dB(A)	75	77	79	75
Total weight with palette, approx.	kg (lbs)	720 (1187)	850 (1876)	1100 (2428)	720 (1587)
Connecting flange					
Inlet port	DN ₁	63 ISO-K	100 ISO-K	160 ISO-K	100 ISO-K
Outlet port	DN ₂	63 ISO-K	63 ISO-K	100 ISO-K	63 ISO-K

Ordering Information

RUTA

		WAU 501/SP250/A	WAU 1001/SP250/A	WAU 2001/SP630(F)/A	WH 700/SP250/A
	Part No.				
RUVAC (WA/WAU/WS/WSU possible)	P2	WAU 501	WAU 1001	WAU 2001	–
RUVAC WH	P2		–	–	WH 700
Backing pump SCREWLINE	P1	SP 250	SP 250	SP 630 (F)	SP 250
Pump system, complete (adaptor version), Without pallet with water-cooled SCREWLINE		502 465 V001	502 467 V001	502 471 V001	503 153 V001 ¹⁾
Frequency converter RUVATRONIC (see description in Chapter “Accessories”)		RT 5/501 500 001 382	RT 5/1001 500 001 383	RT 5/2001 500 001 384	– –

¹⁾ Including external frequency converter

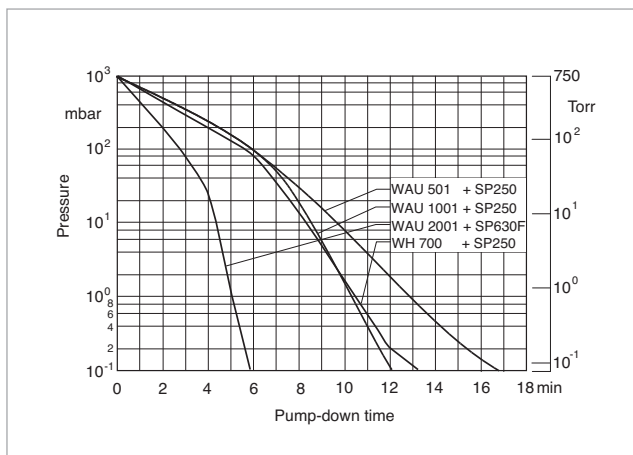

Pump-down time diagram for a 10 m^3 tank at 50 Hz

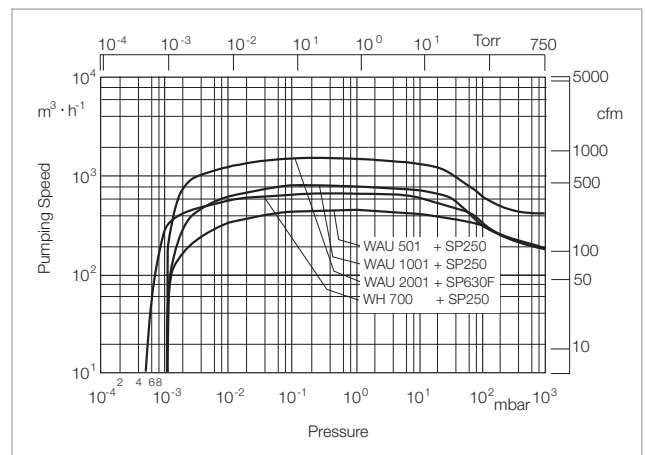

Pumping speed diagram at 50 Hz

Dry Compressing Vacuum Pump System RUTA with SCREWLINE Backing Pump, Adaptor Version, with palette

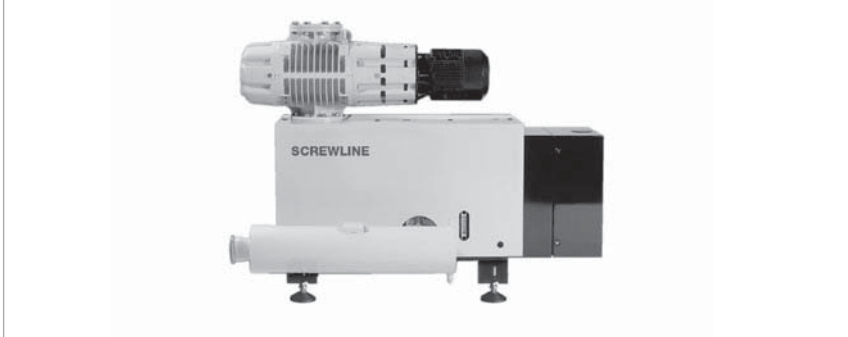

RUTA WAU2001/SP630/A

Standard Equipment

- RUVAC WAU with air cooling
- Silencer
- SP-GUARD
- Manually operated gas ballast
- Gear oil collecting pan integrated within the screw pump
- Gear oil supplied with the pump
- Screw pump SCREWLINE SP 630 F with water cooling

- Screw pump SCREWLINE SP 250 with air cooling
- CE approval

- Castors
- Different types of floor mounts
- Oil drain valve on each pump
- Electric control systems

Options

- Condensate drain valve at the silencer
- Sound proofing box
- Vibration absorbers

- Non-return valve
- Screw pump SCREWLINE SP 630 with air cooling

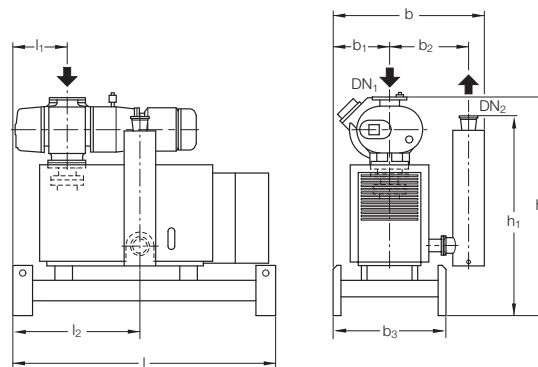

Type	with palette			
	RUTA	501/SP250/A	1001/SP250/A	2001/SP630F/A
RUVAC WA/WAU/WS/WSU	P2	501	1001	2001
Backing pump SCREWLINE	P1	SP 250	SP 250	SP 630 F
	DN ₁	63 ISO-K	100 ISO-K	160 ISO-K
	DN ₂	63 ISO-K	63 ISO-K	100 ISO-K
	l	1448 (57.01)	1488 (58.58)	1850 (72.84)
	l ₁	287 (11.30)	327 (12.87)	379 (14.92)
	l ₂	581 (22.87)	621 (24.45)	894 (35.20)
	b	923 (36.34)	923 (36.34)	1056 (41.58)
	b ₁	400 (15.75)	400 (15.75)	400 (15.75)
	b ₂	438 (17.24)	438 (17.24)	546 (21.50)
	b ₃	800 (31.50)	800 (31.50)	800 (31.50)
	h	1377 (54.21)	1403 (55.24)	1509 (59.41)
	h ¹	1121 (44.13)	1121 (44.13)	1388 (54.65)

Dimensional drawing of the pump systems with dry compressing SCREWLINE SP backing pump, adaptor version; left and middle with palette, right on castors
Dimensions in brackets () are in inch

Technical Data, 50 Hz

RUTA WAU

		501/SP250/A	1001/SP250/A	2001/SP630(F)/A
RUVAC (WA/WAU/WS/WSU possible)	P2	501	1001	2001
Backing pump SCREWLINE	P1	SP 250	SP 250	SP 630 (F)
Pumping speed, 50 Hz at 10^{-1} mbar (7.5×10^{-2} Torr)	$\text{m}^3 \times \text{h}^{-1}$ (cfm)	445.0 (262.1)	830.0 (488.9)	1745.0 (1027.8)
Ultimate total pressure without gas ballast	mbar (Torr)	$< 1 \times 10^{-3}$ ($< 7.5 \times 10^{-4}$)	$< 1 \times 10^{-3}$ ($< 7.5 \times 10^{-4}$)	$< 1 \times 10^{-3}$ ($< 7.5 \times 10^{-4}$)
Installed motor power 400 V, 50 Hz	kW (hp)	9.7 (13.2)	11.5 (15.6)	22.5 (30.6)
Electrical power consumption at 10^{-1} mbar (7.5×10^{-2} Torr)	kW (hp)	6.3 (8.6)	6.7 (9.1)	12.0 (16.3)
Noise level with silencer at 10^{-1} mbar (7.5×10^{-2} Torr)	dB(A)	75	77	79
Total weight with palette, approx.	kg (lbs)	720.0 (1589.4)	850.0 (1876.4)	1100.0 (2428.3)
Connecting flange				
Inlet port	DN ₁	63 ISO-K	100 ISO-K	160 ISO-K
Outlet port	DN ₂	63 ISO-K	63 ISO-K	100 ISO-K

Ordering Information

RUTA WAU

		501/SP250/A	1001/SP250/A	2001/SP630(F)/A
		Part No.	Part No.	Part No.
RUVAC (WA/WAU/WS/WSU possible)	P2	WAU 501	WAU 1001	WAU 2001
Backing pump SCREWLINE	P1	SP 250	SP 250	SP 630 (F)
Pump system, complete (adaptor version), pallet mounted, with water-cooled SCREWLINE		-	-	502 472 V002
with air-cooled SCREWLINE		502 466 V001	502 468 V001	502 472 V003
Frequency converter RUVATRONIC (see description in Chapter "Accessories")		RT 5/501 500 001 382	RT 5/1001 500 001 383	RT 5/2001 500 001 384

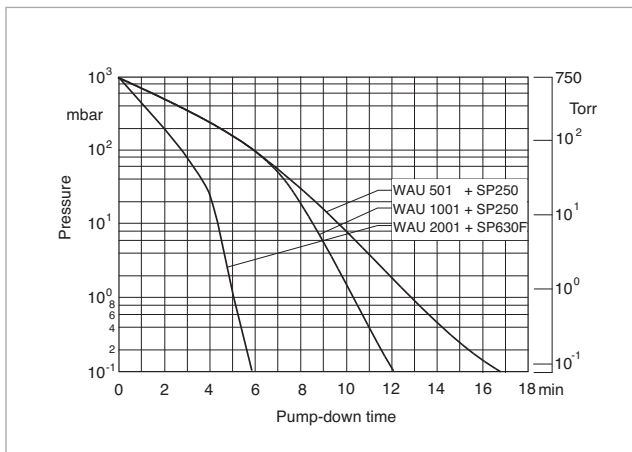

Pump-down time diagram for a 10 m^3 tank at 50 Hz

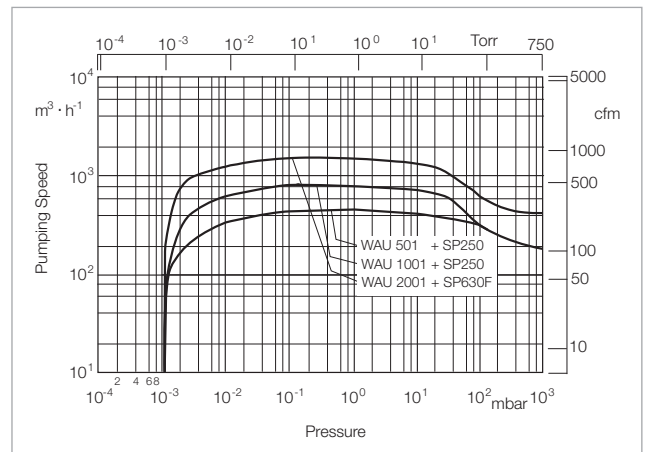

Pumping speed diagram at 50 Hz

Dry Compressing Vacuum Pump System RUTA with SCREWLINE Backing Pump, Adaptor Version, with palette

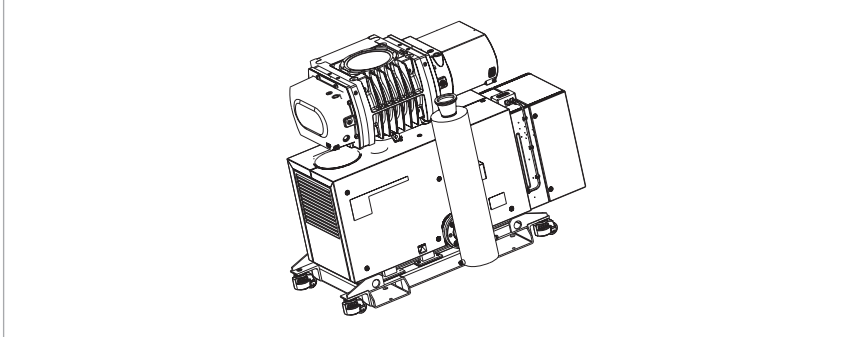

RUTA WH4400/SP630F/A on castors

Standard Equipment

- RUVAC WH with water cooling
- Silencer
- SP-GUARD
- Manually operated gas ballast
- Gear oil collecting pan integrated within the screw pump
- Gear oil supplied with the pump
- Screw pump SCREWLINE SP 630 F with water cooling
- RUVAC WH including external frequency converter (frequency converter permits pumping speed control)
- CE approval
- Sound proofing box
- Vibration absorbers
- Castors
- Different types of floor mounts
- Oil drain valve on each pump
- Electric control systems
- Non-return valve
- Screw pump SCREWLINE SP 630 with air cooling

Options

- Condensate drain valve at the silencer

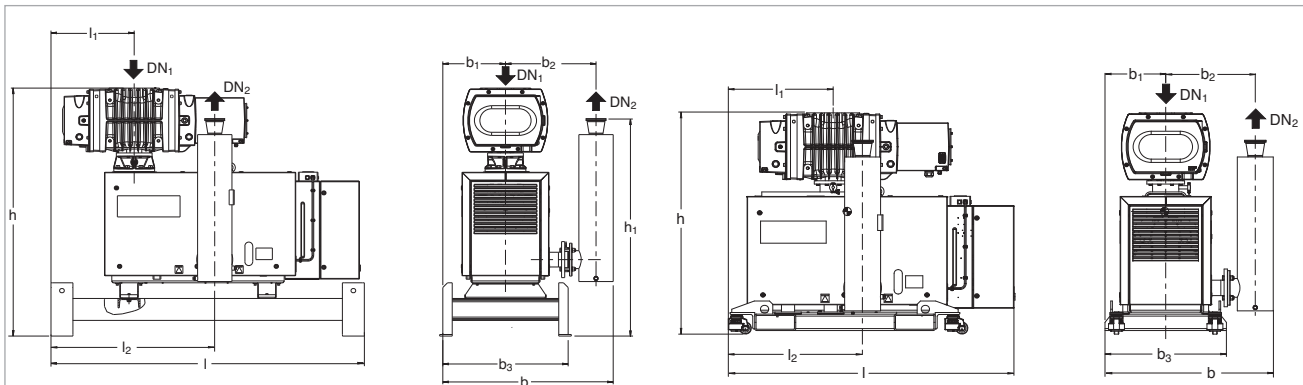

Type		with palette	on castors
RUTA	P2	4400/SP630F/A	4400/SP630F/A
RUVAC WH	P2	4400	4400
Backing pump SCREWLINE	P1	SP 630 F	SP 630 F
	DN ₁	250 ISO-K	250 ISO-K
	DN ₂	100 ISO-K	100 ISO-K
	l	2000 (78.74)	1748 (68.82)
	l ₁	531 (20.91)	639 (25.16)
	l ₂	1045 (41.14)	819 (32.24)
	b	1088 (42.84)	1026 (40.39)
	b ₁	400 (15.75)	370 (14.57)
	b ₂	578 (22.76)	546 (21.50)
	b ₃	800 (31.50)	740 (21.13)
	h	1583 (62.32)	1354 (53.31)
	h ₁	1388 (54.65)	1182 (46.54)

Dimensional drawing of the pump systems with dry compressing SCREWLINE SP backing pump, adaptor version; left with palette, right on castors. Dimensions in brackets () are in inch

Technical Data, 50 Hz

RUTA WH 4400/SP630F/A

RUVAC WH	P2	4400
Backing pump SCREWLINE	P1	SP 630 F
Pumping speed, 50 Hz at 10^{-1} mbar (7.5×10^{-2} Torr)	$\text{m}^3 \times \text{h}^{-1}$ (cfm)	3380 (1990)
Ultimate total pressure without gas ballast	mbar (Torr)	$< 1 \times 10^{-3}$ ($< 7.5 \times 10^{-4}$)
Installed motor power 400 V, 50 Hz	kW (hp)	26.0 (34.9)
Electrical power consumption at 10^{-1} mbar (7.5×10^{-2} Torr)	kW (hp)	12.93 (17.34)
Noise level with silencer at 10^{-1} mbar (7.5×10^{-2} Torr)	dB(A)	73
Total weight with palette, approx.	kg (lbs)	1350 (2932)
on castors, approx.	kg (lbs)	1980 (4365)
Connecting flange		
Inlet port	DN ₁	250 ISO-K
Outlet port	DN ₂	100 ISO-K

Ordering Information

RUTA WH 4400/SP630F/A

		Part No.
RUVAC WH	P2	4400
Backing pump SCREWLINE	P1	SP 630 F
Pump system, complete (adaptor version), with water-cooled SCREWLINE pallet mounted		503 162 V001 ¹⁾
castor mounted		502 873 V001 ¹⁾

¹⁾ Including external frequency converter

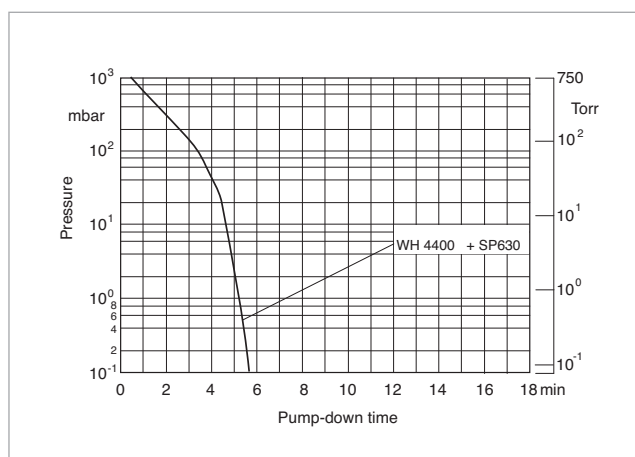

Pump-down time diagram for a 10 m^3 tank at 50 Hz

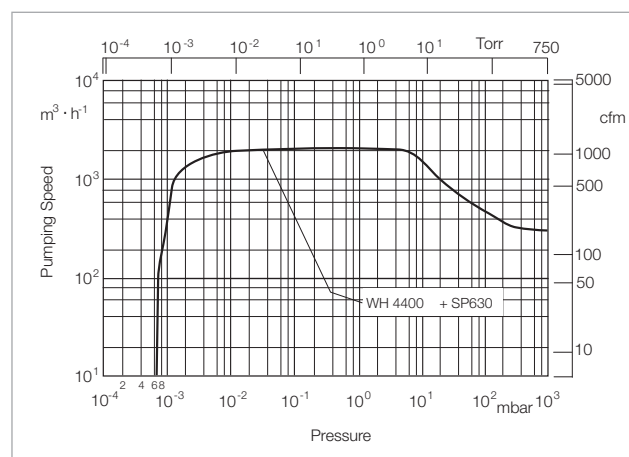

Pumping speed diagram at 50 Hz

Dry Compressing Vacuum Pump System RUTA with SCREWLINE SP 250 Backing Pump, Frame Version

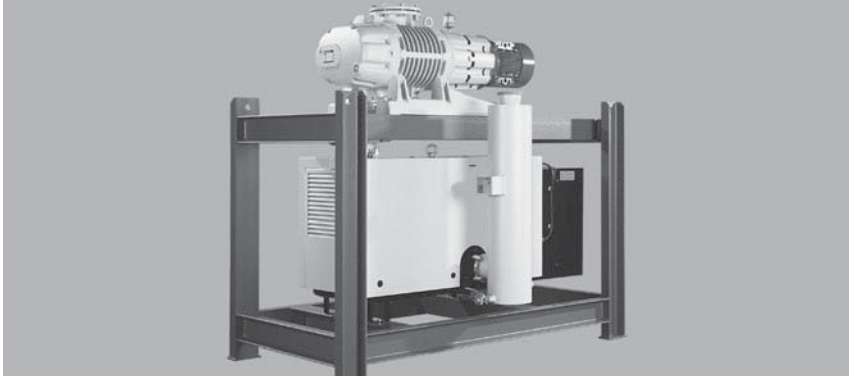

RUTA WAU2001/SP630/G

Standard Equipment

- RUVAC WH with water cooling
- RUVAC WAU with air cooling
- SCREWLINE SP 250 with air cooling
- Silencer
- SP-GUARD
- Manually operated gas ballast
- SECUVAC valve 24 V DC
- Gear oil collecting pan integrated within the screw pump

- Crane eyes on the frame
- Floor mounting
- Gear oil supplied with the pump
- Screw pump with air cooling
- RUVAC WH including external frequency converter (frequency converter permits pumping speed control)
- CE approval

Options

- Condensate drain valve at the silencer
- Sound proofing box
- Vibration absorbers
- Castors
- Different types of floor mounts
- Oil drain valve on each pump
- Electric control systems
- Non-return valve

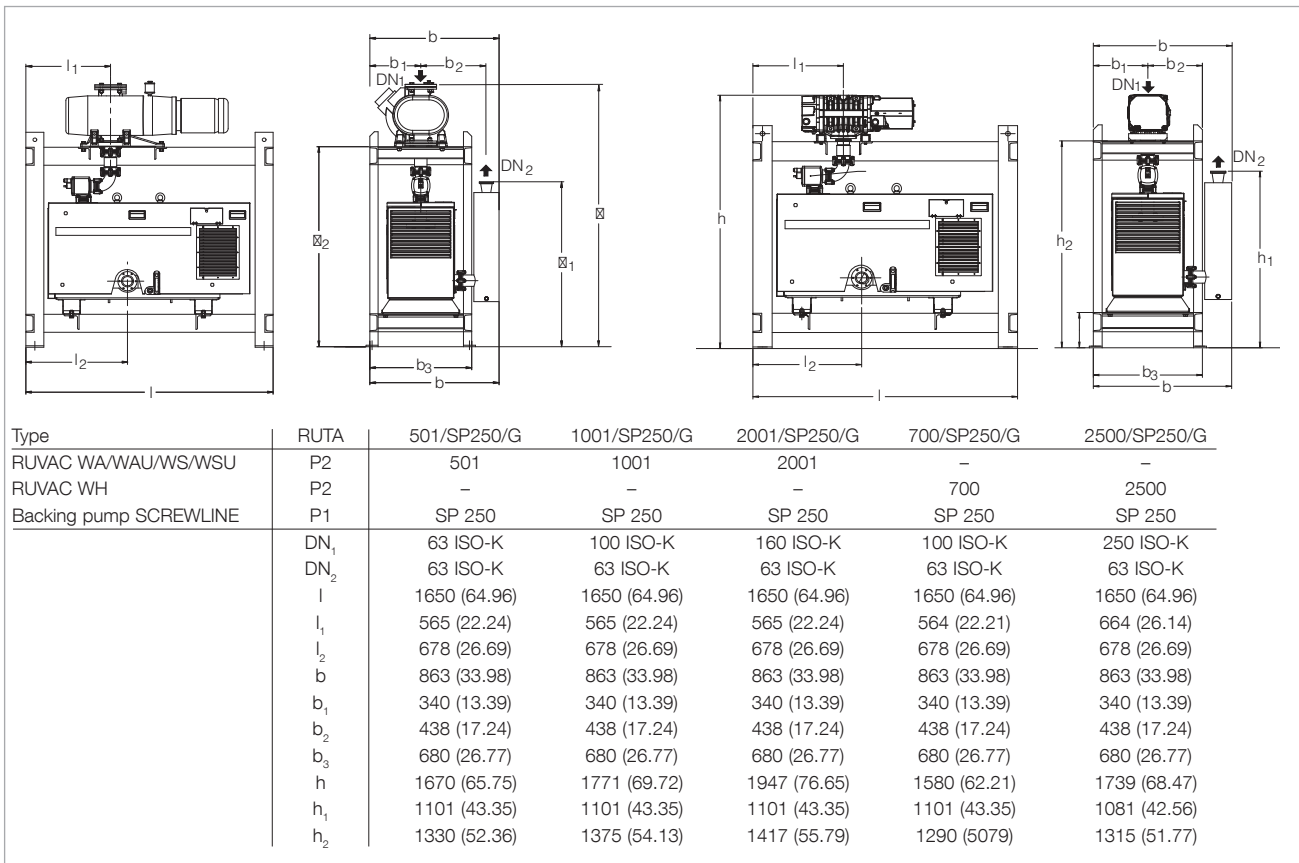

Dimensional drawing of the pump systems with dry compressing SCREWLINE SP 250 backing pump, frame version; dimensions in brackets () are in inch

Technical Data, 50 Hz

		WAU 501/ SP250/G	WAU 1001/ SP250/G	RUTA WAU 2001/ SP250/G	WH 700/ SP250/G	WH 2500/ SP250/G
RUVAC (WA/WAU/WS/WSU possible)	P2	501	1001	2001	–	–
RUVAC WH	P2	–	–	–	700	2500
Backing pump SCREWLINE	P1	SP 250	SP 250	SP 250	SP 250	SP 250
Pumping speed, 50 Hz at 10 ⁻¹ mbar (7.5 x 10 ⁻² Torr)	m ³ x h ⁻¹ (cfm)	445 (262)	830.0 (489)	1530 (901)	635 (374)	1680 (988)
Ultimate total pressure without gas ballast	mbar (Torr)	< 1 x 10 ⁻³ (< 0.75 x 10 ⁻³)	< 1 x 10 ⁻³ (< 0.75 x 10 ⁻³)	< 1 x 10 ⁻³ (< 0.75 x 10 ⁻³)	< 1 x 10 ⁻³ (< 0.75 x 10 ⁻³)	< 3 x 10 ⁻³ (< 2.2 x 10 ⁻³)
Installed motor power 400 V, 50 Hz	kW (hp)	9.7 (13.2)	11.5 (15.6)	15.0 (20.4)	9.7 (13.2)	13.5 (18.1)
Electrical power consumption at 10 ⁻¹ mbar (7.5 x 10 ⁻² Torr)	kW (hp)	6.3 (8.6)	6.7 (9.1)	7.6 (10.3)	6.6 (8.9)	7.3 (9.8)
Noise level with silencer at 10 ⁻¹ mbar (7.5 x 10 ⁻² Torr)	dB(A)	74	77	80	75	70
Weight, total, approx.	kg (lbs)	860 (1896)	950 (2097)	1140 (2517)	860 (1896)	1000 (2205)
Connecting flange Inlet port	DN ₁	63 ISO-K	100 ISO-K	160 ISO-K	100 ISO-K	250 ISO-K
Outlet port	DN ₂	63 ISO-K	63 ISO-K	63 ISO-K	63 ISO-K	63 ISO-K

Ordering Information

		WAU 501/ SP250/G	WAU 1001/ SP250/G	RUTA WAU 2001/ SP250/G	WH 700/ SP250/G	WH 2500/ SP250/G
		Part No.	Part No.	Part No.	Part No.	Part No.
RUVAC (WA/WAU/WS/WSU possible)	P2	WAU 501	WAU 1001	WAU 2001	–	–
RUVAC WH	P2	–	–	–	700	2500
Backing pump SCREWLINE	P1	SP 250	SP 250	SP 250	SP 250	SP 250
Pump system, complete (adaptor version), frame mounted, with Roots vacuum pump RUVAC WAU RUVAC WH		502 531 V001 –	502 532 V001 –	502 533 V001 –	– 503 154 V001 ¹⁾	– 503 158 V001 ^{1, 2)}
Frequency converter RUVATRONIC (see description in Chapter “Accessories”)		RT 5/501 500 001 382	RT 5/1001 500 001 383 ²⁾	RT 5/2001 500 001 384 ²⁾	– –	– –

¹⁾ Including external frequency converter

²⁾ With this combination, continuous operation of the Roots pump is not possible at atmospheric pressure

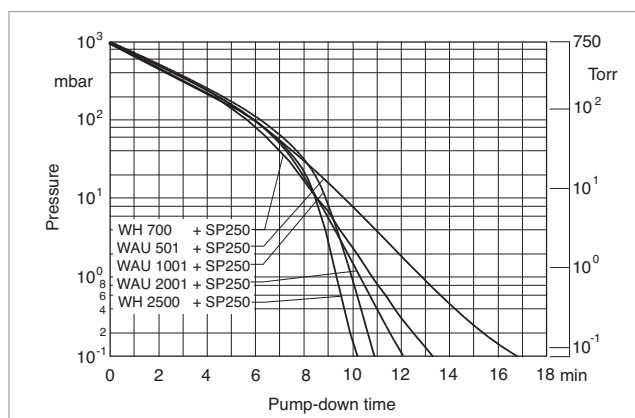

Pump-down time diagram for a 10 m³ tank at 50 Hz

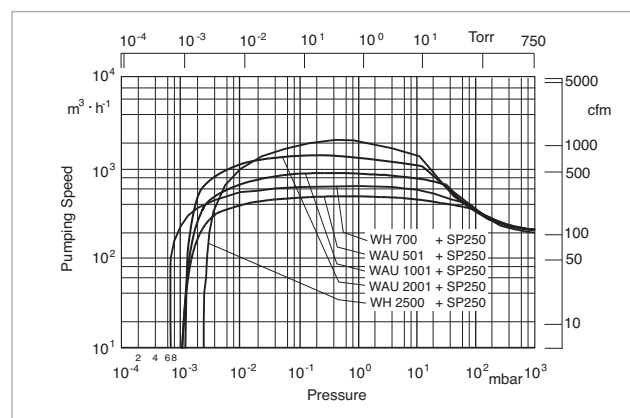

Pumping speed diagram at 50 Hz

Dry Compressing Vacuum Pump System RUTA with SCREWLINE SP 630 F Backing Pump, Frame Version

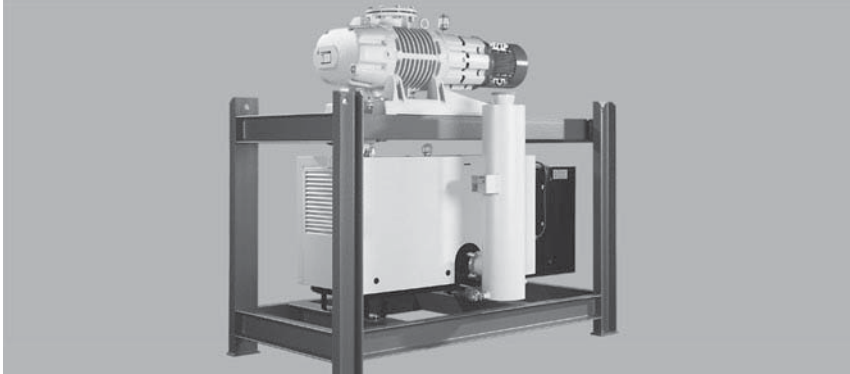

RUTA WAU2001/SP630F/G

Standard Equipment

- RUVAC RA with water cooling
- SCREWLINE SP 630 F with water cooling
- Silencer
- SP-GUARD
- Manually operated gas ballast
- SECUVAC valve 24 V DC
- Gear oil collecting pan integrated within the screw pump
- Crane eyes on the frame

- Floor mounting
- Gear oil supplied with the pump
- CE approval

Options

- Frequency converter RUVATRONIC RT for controlling the speed of the Roots pump
- Condensate drain valve at the silencer

- Sound proofing box
- Vibration absorbers
- Castors
- Different types of floor mounts
- Oil drain valve on each pump
- Electric control systems
- Non-return valve
- Screw pump with air cooling

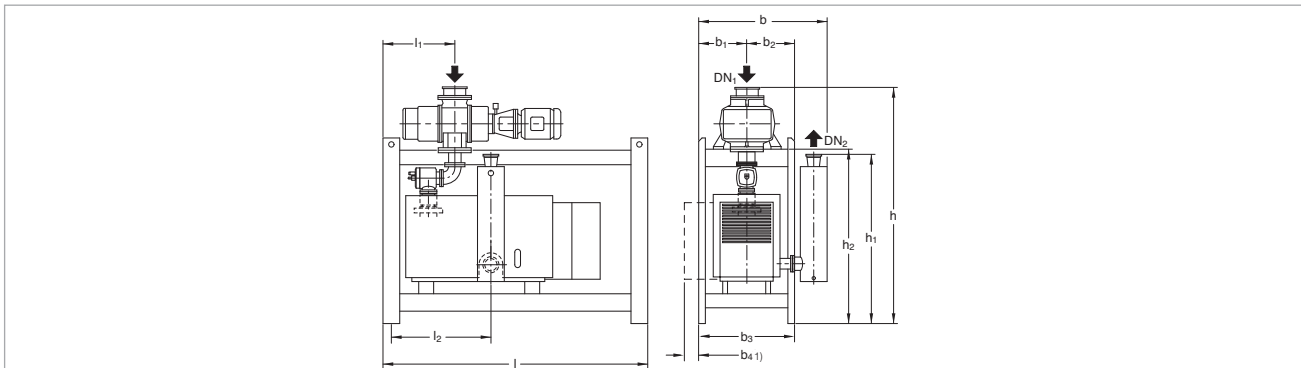

Type	RUTA	3001/SP630F/G	5001/SP630F/G	7001/SP630F/G	9001/SP630F/G
RUVAC RA	P2	3001	5001	7001	9001
Backing pump SCREWLINE	P1	SP 630 F	SP 630 F	SP 630 F	SP 630 F
	DN ₁	250 ISO-K	250 ISO-K	250 ISO-K	320 ISO-K
	DN ₂	100 ISO-K	100 ISO-K	100 ISO-K	100 ISO-K
	l	1960 (77.17)	2400 (94.49)	1960 (77.17)	2340 (92.13)
	l ₁	600 (23.62)	701 (27.60)	600 (23.62)	727 (28.62)
	l ₂	895 (35.24)	995 (39.17)	895 (35.24)	1021 (40.20)
	b	1056 (41.58)	1116 (43.94)	1116 (43.94)	1171 (46.10)
	b ₁	400 (15.75)	460 (18.11)	460 (18.11)	515 (20.28)
	b ₂	546 (21.50)	546 (21.50)	546 (21.50)	546 (21.50)
	b ₃	800 (31.50)	930 (36.61)	920 (36.22)	1030 (40.55)
	h	2025 (79.72)	2215 (87.21)	2156 (84.88)	2235 (87.99)
	h ₁	1388 (54.65)	1388 (54.65)	1388 (54.65)	1388 (54.65)
	h ₂	1411 (55.55)	1411 (55.55)	1411 (55.55)	1411 (55.55)

Dimensional drawing of the pump systems RUTA with dry compressing SCREWLINE SP 630 F backing pump, frame version; dimensions in brackets () are in inch

Technical Data, 50 Hz

RUTA RA

3001/SP630F/G 5001/SP630F/G 7001/SP630F/G 9001/SP630F/G

RUVAC RA	P2	3001	5001	7001	9001
Backing pump SCREWLINE	P1	SP 630 F	SP 630 F	SP 630 F	SP 630 F
Pumping speed, 50 Hz at 10^{-1} mbar (7.5×10^{-2} Torr)	$\text{m}^3 \times \text{h}^{-1}$ (cfm)	3050 (1797)	4040.0 (2379.6)	5030 (2963)	6000 (3534)
Ultimate total pressure without gas ballast	mbar (Torr)	$< 1 \times 10^{-3}$ ($< 0.75 \times 10^{-3}$)	$< 1 \times 10^{-3}$ ($< 0.75 \times 10^{-3}$)	$< 1 \times 10^{-3}$ ($< 0.75 \times 10^{-3}$)	$< 1 \times 10^{-3}$ ($< 0.75 \times 10^{-3}$)
Installed motor power 400 V, 50 Hz	kW (hp)	26.0 (35.0)	30.0 (40.0)	33.5 (45.0)	37.0 (50.0)
Electrical power consumption at 10^{-1} mbar (7.5×10^{-2} Torr)	kW (hp)	13.4 (18.2)	13.5 (18.4)	13.6 (18.5)	13.2 (18.0)
Noise level with silencer at 10^{-1} mbar (7.5×10^{-2} Torr)	dB(A)	82	79	82	80
Weight, total, approx.	kg (lbs)	1550 (3420)	1900 (4190)	2000 (4410)	2630 (5800)
Connecting flange					
Inlet port	DN ₁	250 ISO-K	250 ISO-K	250 ISO-K	320 ISO-K
Outlet port	DN ₂	100 ISO-K	100 ISO-K	100 ISO-K	100 ISO-K

Ordering Information

RUTA RA

3001/SP630F/G 5001/SP630F/G 7001/SP630F/G 9001/SP630F/G

		Part No.	Part No.	Part No.	Part No.
RUVAC	P2	RA 3001	RA 5001	RA 7001	RA 9001
Backing pump SCREWLINE	P1	SP 630 F	SP 630 F	SP 630 F	SP 630 F
Pump system, complete (adaptor version), frame mounted, with Roots vacuum pump RUVAC RA with air-cooled vacuum pump Screw pump SCREWLINE SP 630		502 512 V001	502 513 V001	502 514 V001	502 515 V001
Frequency converter RUVATRONIC (see description in Chapter "Accessories")		RT 5/3001 500 001 385 ¹⁾	RT 5/5001 500 001 386 ¹⁾	RT 5/7001 500 001 387 ¹⁾	RT 5/9001 500 001 388 ¹⁾

¹⁾ With this combination, continuous operation of the Roots pump is not possible at atmospheric pressure

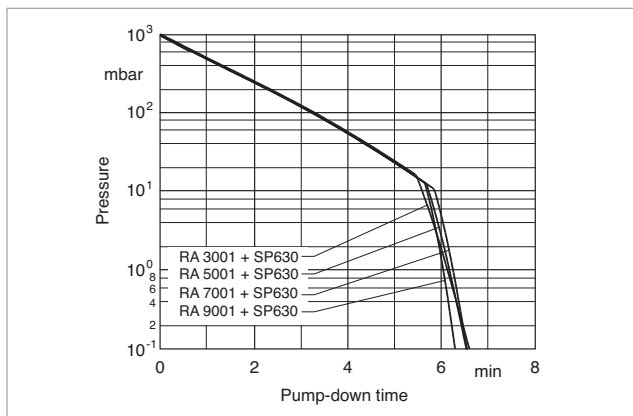

Pump-down time diagram for a 10 m³ tank at 50 Hz

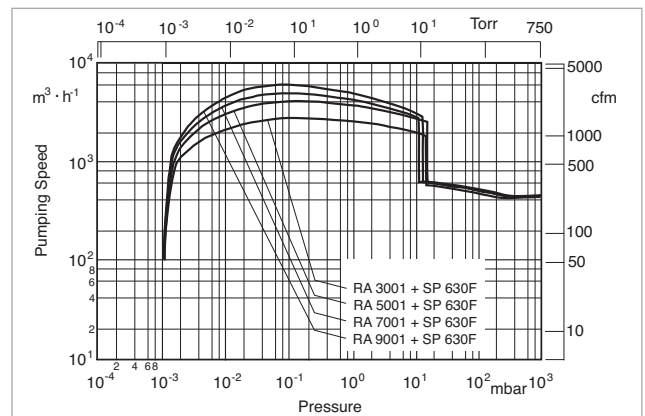

Pumping speed diagram at 50 Hz

Dry Compressing Vacuum Pump System RUTA with SCREWLINE SP 630 F Backing Pump, Frame Version

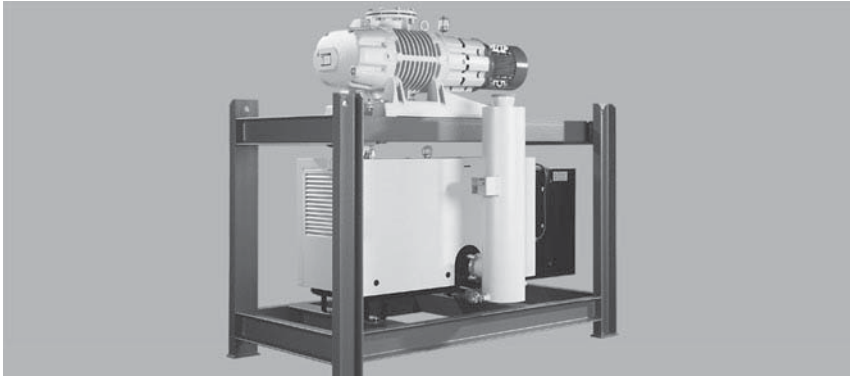

RUTA WAU2001/SP630F/G

Standard Equipment

- RUVAC WH with water cooling
- RUVAC WAU with air cooling
- SCREWLINE SP 630 F with water cooling
- Silencer
- SP-GUARD
- Manually operated gas ballast
- SECUVAC valve 24 V DC
- Gear oil collecting pan integrated within the screw pump
- Crane eyes on the frame
- Floor mounting
- Gear oil supplied with the pump
- RUVAC WH including external frequency converter (frequency converter permits pumping speed control)
- CE approval
- Condensate drain valve at the silencer
- Sound proofing box
- Vibration absorbers
- Different types of floor mounts
- Oil drain valve on each pump
- Electric control systems
- Non-return valve
- Screw pump with air cooling

Options

- Frequency converter for controlling the speed of the Roots pump (only RUVAC RA/WA/WS)

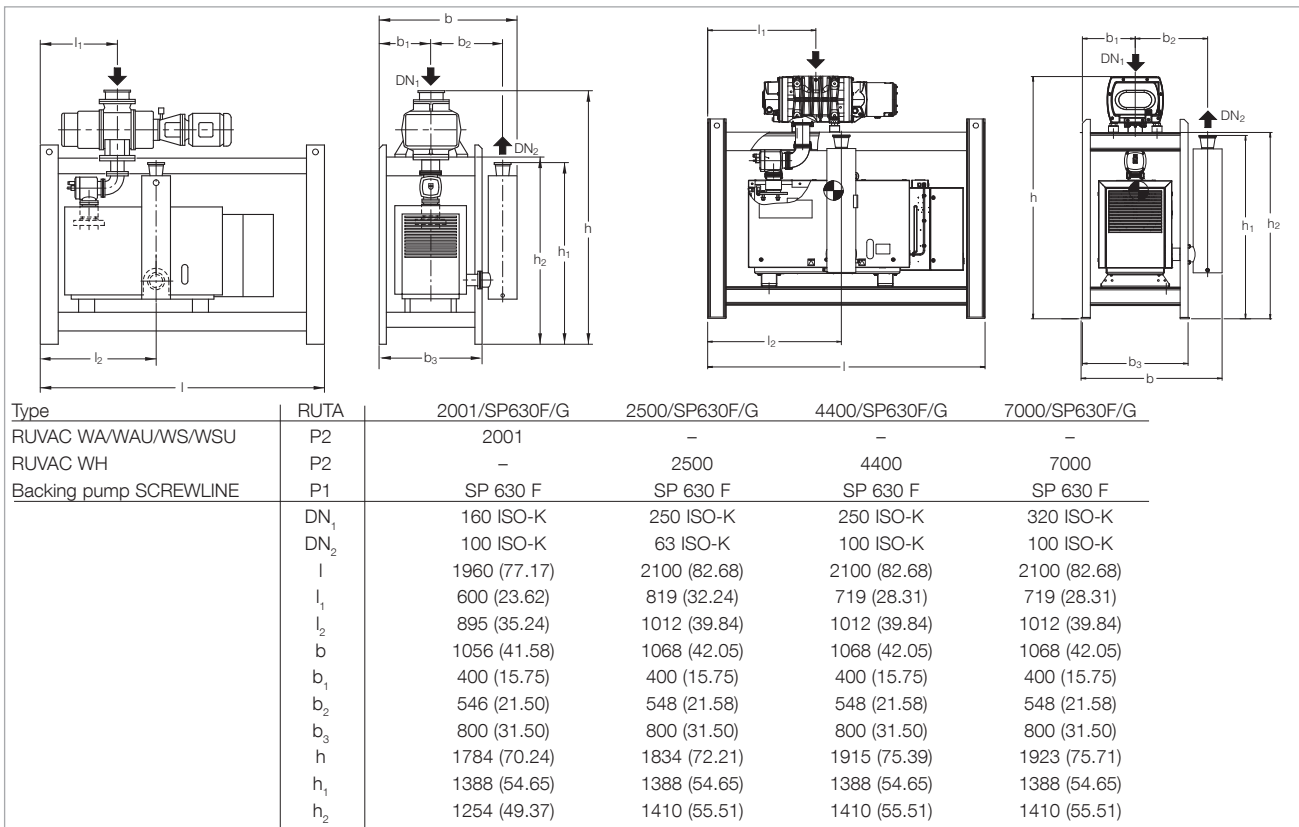

Dimensional drawing of the pump systems RUTA with dry compressing SCREWLINE SP 630 F backing pump, frame version; dimensions in brackets () are in inch

Technical Data, 50 Hz

RUTA

		WAU 2001/SP630F/G	WH 2500/SP630F/G	WH 4400/SP630F/G	WH 7000/SP630F/G
RUVAC (WA/WAU/WS/WSU possible)	P2	2001	–	–	–
RUVAC WH	P2	–	2500	4400	7000
Backing pump SCREWLINE	P1	SP 630 F	SP 630 F	SP 630 F	SP 630 F
Pumping speed, 50 Hz at 10 ⁻¹ mbar (7.5 x 10 ⁻² Torr)	m ³ x h ⁻¹ (cfm)	1745 (1028)	1956 (1151)	3380 (1990)	5093 (2998)
Ultimate total pressure without gas ballast	mbar (Torr)	< 1 x 10 ⁻³ (< 0.75 x 10 ⁻³)	< 5 · 10 ⁻³ (< 3.7 x 10 ⁻³)	< 1 x 10 ⁻³ (< 0.75 x 10 ⁻³)	< 1 x 10 ⁻³ (< 0.75 x 10 ⁻³)
Installed motor power 400 V, 50 Hz	kW (hp)	22.5 (30.0)	21.5 (28.8)	26.0 (34.9)	26.0 (34.9)
Electrical power consumption at 10 ⁻¹ mbar (7.5 x 10 ⁻² Torr)	kW (hp)	12.0 (16.3)	11.7 (16.7)	12.93 (17.34)	13.11 (17.58)
Noise level with silencer at 10 ⁻¹ mbar (7.5 x 10 ⁻² Torr)	dB(A)	79	73	73	73
Weight, total, approx.	kg (lbs)	1300 (2866)	1300 (2866)	1550 (3417)	1600 (3527)
Connecting flange					
Inlet port	DN ₁	160 ISO-K	250 ISO-K	250 ISO-K	320 ISO-K
Outlet port	DN ₂	100 ISO-K	63 ISO-K	100 ISO-K	100 ISO-K

Ordering Information

RUTA

		WAU 2001/SP630F/G	WH 2500/SP630F/G	WH 4400/SP630F/G	WH 7000/SP630F/G
	Part No.	Part No.	Part No.	Part No.	Part No.
RUVAC (WA/WAU/WS/WSU possible)	P2	WAU 2001	–	–	–
RUVAC WH	P2	–	2500	4400	7000
Backing pump SCREWLINE	P1	SP 630 F	SP 630 F	SP 630 F	SP 630 F
Pump system, complete (adaptor version), frame mounted, with Roots vacuum pump RUVAC WAU		502 511 V001	–	–	–
with Roots vacuum pump RUVAC WH		–	503 159 V001 ^{1), 2)}	503 163 V001 ^{1), 2)}	503 168 V001 ^{1), 2)}
Frequency converter RUVATRONIC (see description in Chapter “Accessories”)		RT 5/2001 500 001 384	–	–	–

¹⁾ Including external frequency converter

²⁾ With this combination, continuous operation of the Roots pump is not possible at atmospheric pressure

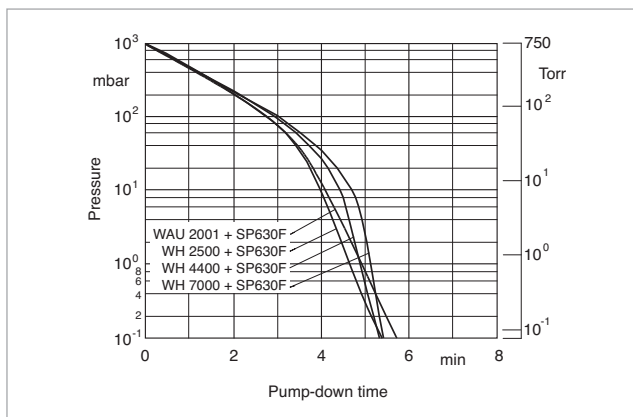

Pump-down time diagram for a 10 m³ tank at 50 Hz

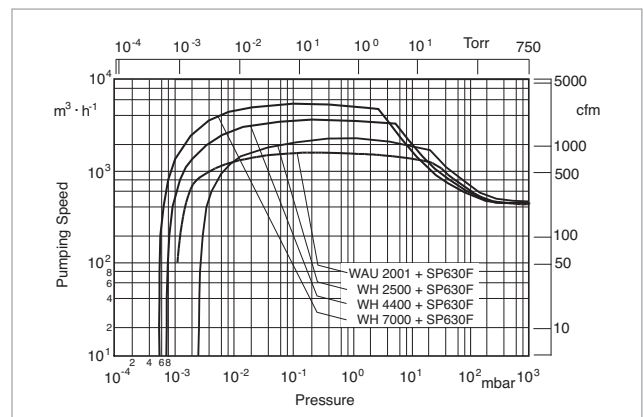

Pumping speed diagram at 50 Hz

Dry Compressing Vacuum Pump System RUTA with SCREWLINE SP 630 F Backing Pump, Adaptor Version

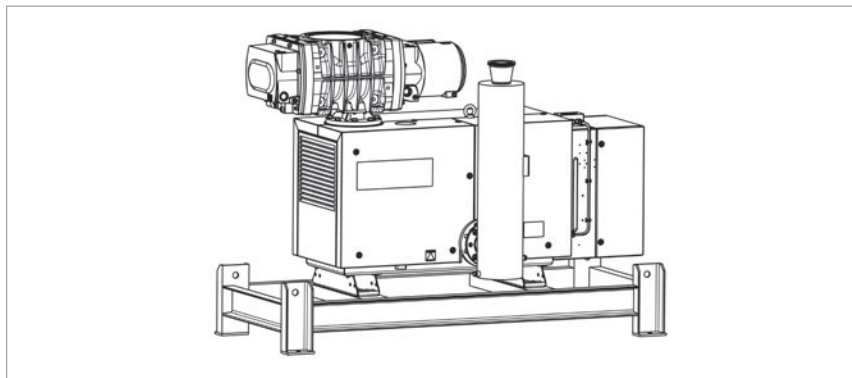

RUTA WH2500/SP630F/A

Standard Equipment

- RUVAC WH with water cooling
- SCREWLINE SP 630 F with water cooling
- Silencer
- SP-GUARD
- Manually operated gas ballast
- SECUVAC valve 24 V DC
- Gear oil collecting pan integrated within the screw pump
- Crane eyes on the frame
- Floor mounting
- Gear oil supplied with the pump
- RUVAC WH including external frequency converter (frequency converter permits pumping speed control)
- Sound proofing box
- Vibration absorbers
- Different types of floor mounts
- Oil drain valve on each pump
- Electric control systems
- Non-return valve
- Screw pump with air cooling

Options

- Condensate drain valve at the silencer

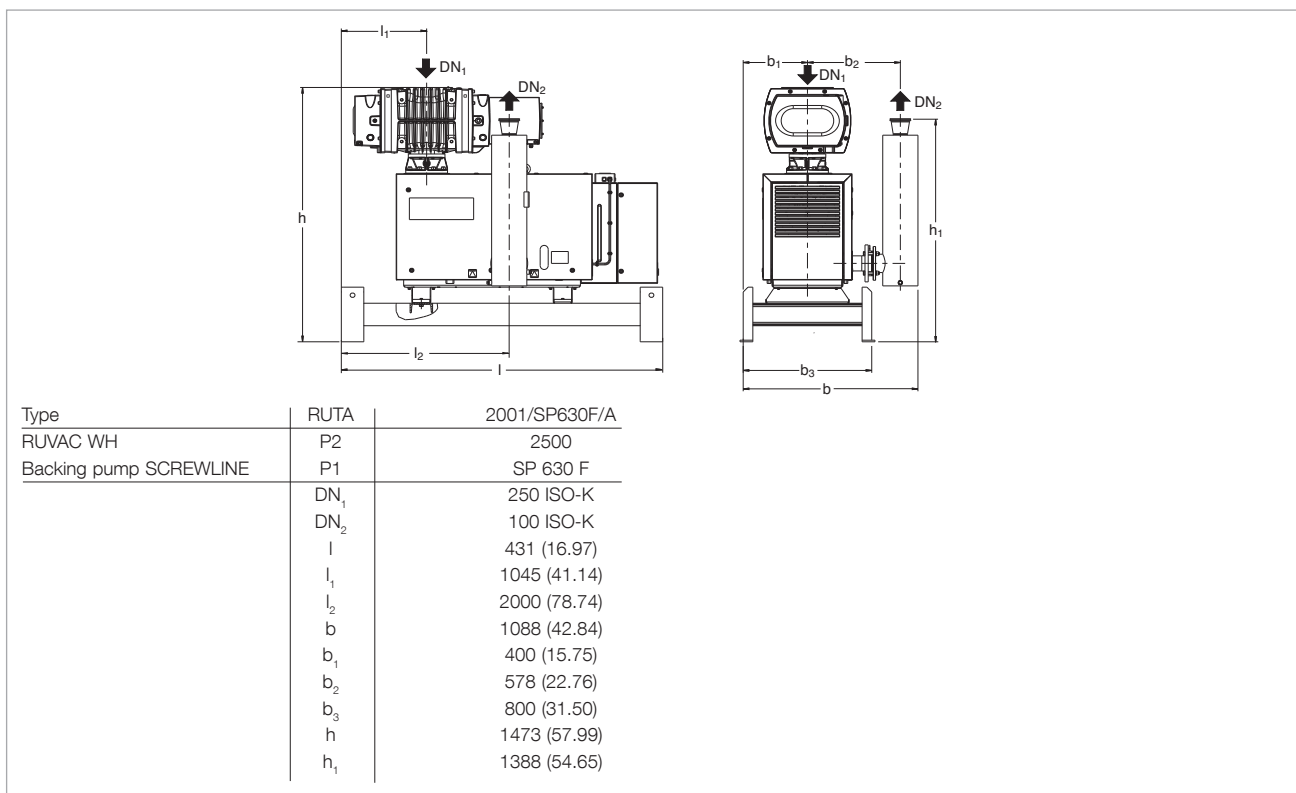

Dimensional drawing of the pump system with dry compressing SCREWLINE SP 630 F backing pump, adaptor version; dimensions in brackets () are in inch

Technical Data, 50 Hz

RUTA WH 2500/SP630F/A

RUVAC WH	P2	2500
Backing pump SCREWLINE	P1	SP 630 F
Pumping speed, 50 Hz at 10 ⁻¹ mbar (7.5 x 10 ⁻² Torr)	m ³ x h ⁻¹ (cfm)	1956 (1151)
Ultimate total pressure without gas ballast	mbar (Torr)	< 5 x 10 ⁻³ (< 3.7 x 10 ⁻³)
Installed motor power 400 V, 50 Hz	kW (hp)	21.5 (28.8)
Electrical power consumption at 10 ⁻¹ mbar (7.5 x 10 ⁻² Torr)	kW (hp)	11.7(16.7)
Noise level with silencer at 10 ⁻¹ mbar (7.5 x 10 ⁻² Torr)	dB(A)	73
Weight, total, approx.	kg (lbs)	1200 (2645)
Connecting flange		
Inlet port	DN ₁	250 ISO-K
Outlet port	DN ₂	100 ISO-K

Ordering Information

RUTA WH 2500/SP630F/A

	Part No.	
RUVAC WH	P2	2500
Backing pump SCREWLINE	P1	SP 630 F
Pump system, complete (adaptor version), pallet mounted, with Roots vacuum pump RUVAC WH		503 160 V001 ¹⁾

¹⁾ Including external frequency converter

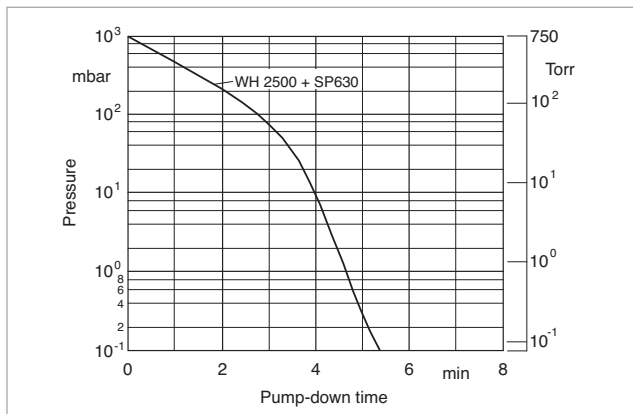

Pump-down time diagram for a 10 m³ tank at 50 Hz

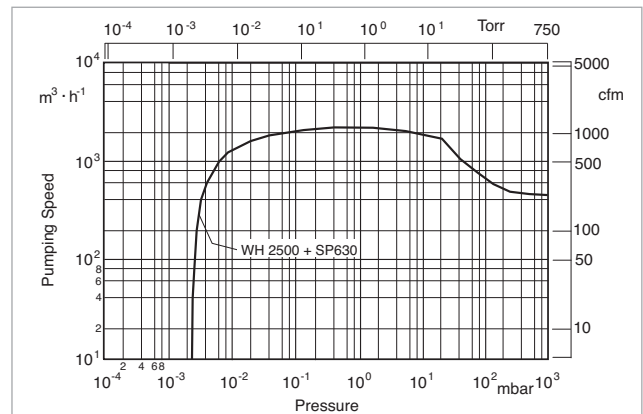

Pumping speed diagram at 50 Hz

Pump Systems (Only available for purchase in North and South America)

SP Close-Coupled Systems with SP Dry Compressing Backing Pumps

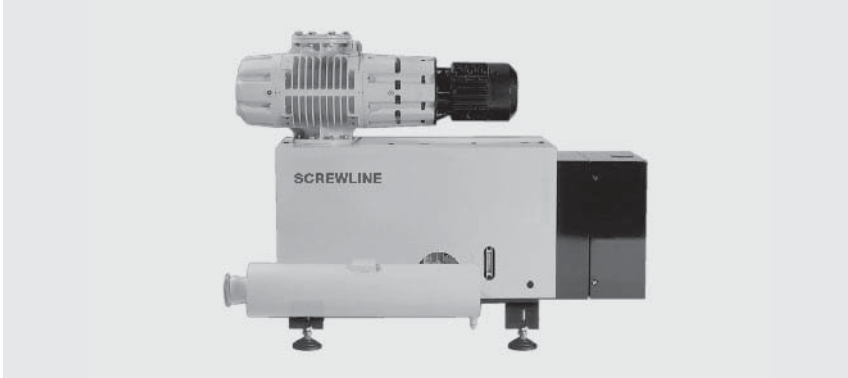

SP close-coupled system

Advantages to the User

- Reduced maintenance and lower operating costs
- Compact close-coupled design without frame
- Oil-free compression in multiple pump stages
- Optimum leak tightness with WSU boosters
- Air-cooled
- Assembled and tested

Standard Equipment

- SCREWLINE SP 630 / WSU 1001 close-coupled pump system offering 645 ACFM at 0.3 Torr vacuum
- SCREWLINE SP 630 / WSU2001 close-coupled pump system offering 1235 ACFM at 0.3 Torr vacuum

Options

- Electrical controls
- Exhaust silencer (loose)
- Inlet filter (loose)

The screw pump SCREWLINE SP 630 dry compressing screw-type vacuum pump is an environmentally friendly alternative to traditional oil sealed rotary piston and vane vacuum pumps. This innovative and robust vacuum pump produces a pumping speed of 371 cfm and better than 0.0075 Torr vacuum. SP 630 major advantages include improved environment, reduced maintenance, lower operating costs through less disposal and the elimination of expensive water cooling all with no oil contamination as the need for lubricating oil in the pumps' compression stage has been eliminated.

When used in conjunction with the Oerlikon Leybold Vacuum WSU booster pumps, pumping speeds can be significantly increased while achieving oil-free compression in multiple vacuum pump stages.

Oerlikon Leybold Vacuum WSU boosters offer a canned motor design, which eliminates the need for shaft seals and flanged-on motors. A vacuum tight can separates the motor rotor and stator coils. This unique Oerlikon Leybold Vacuum design provides the advantage of a more leak tight vacuum system. The WSU version booster incorporates a by-pass valve feature, which allows for automatic adjustment to varying pressure differentials between the inlet and outlet of the pump. The result is elimination of costly pressure switches/ amplifiers and faster pump down while starting at atmospheric pressure with the aforementioned SP 630 vacuum pump.

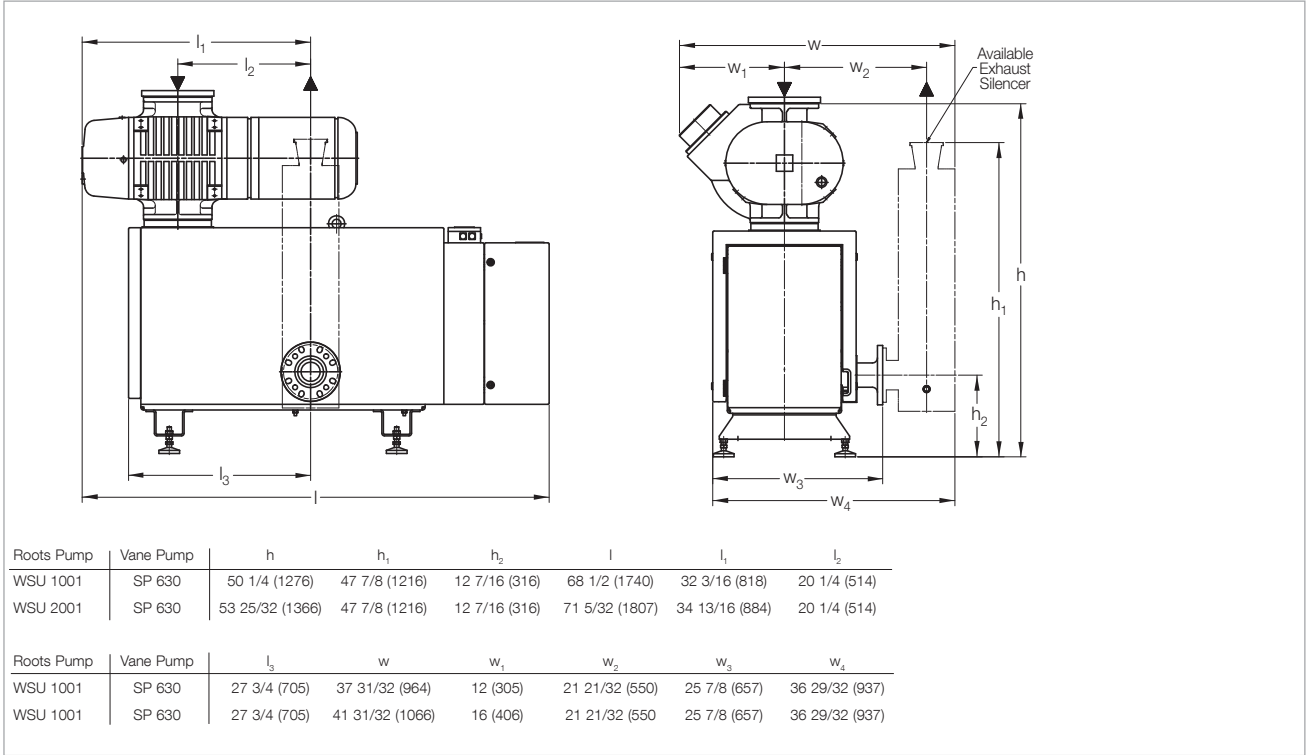

Dimensional drawing for the SP close-coupled system with SCREWLINE SP 630 dry compressing backing pumps; dimensions in brackets () are in mm

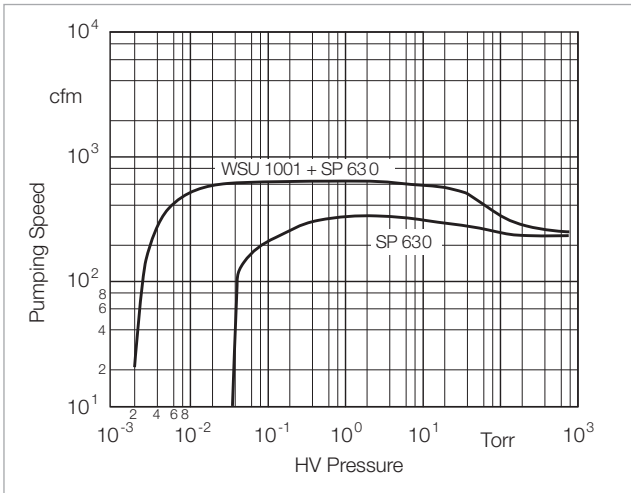

Pumping speed diagram for the SP close-coupled system with WSU 1001 Roots blower and SCREWLINE SP 630 at 60 Hz

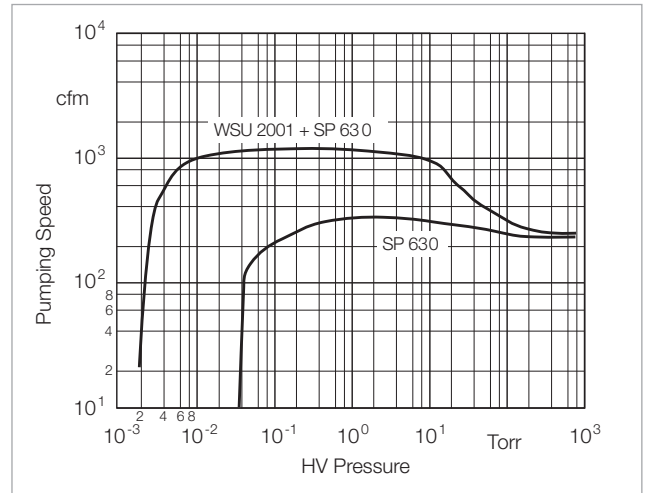

Pumping speed diagram for the SP close-coupled system with WSU 2001 Roots blower and SCREWLINE SP 630 at 60 Hz

Technical Data, 60 Hz

SP Close-Coupled Systems

1001/SP630

2001/SP630

RUVAC (WSU possible)	P2	1001	2001
Backing pump SCREWLINE	P1	SP 630	SP 630
Pumping speed 60 Hz at 0.3 Torr	m ³ x h ⁻¹ (cfm)	1.092 (643)	2.085 (1,227)
Ultimate total pressure without gas ballast	mbar (Torr)	< 1 x 10 ⁻³ (< 7.5 x 10 ⁻⁴)	< 1 x 10 ⁻³ (< 7.5 x 10 ⁻⁴)
Installed motor power	kW (hp)	16.2 (21.6)	22.5 (30.0)
Noise level with silencer at 10 ⁻¹ mbar (7.5 x 10 ⁻² Torr)	dB(A)	78	79
Weight, total, approx.	kg (lbs)	870 (1922)	1100 (2430)
Connecting flange Inlet port	DN ₁	160 ISO-K	160 ISO-K
Outlet port	DN ₂	100 ISO-K	100 ISO-K

Ordering Information

SP Close-Coupled Systems

1001/SP630

2001/SP630

		Part No.	Part No.
RUVAC (WA/WAU/WS/WSU possible)	P2	WSU 1001	WSU 2001
Backing pump SCREWLINE	P1	SP 630	SP 630
Pump system, complete (adaptor version), pallet mounted, with Roots vacuum pump RUVAC WAU		180 038 V1600	180 038 V2600

Further Products

Dry Compressing Vacuum Pump System RUTA with DRYVAC DV 650 Backing Pump, Adaptor Version

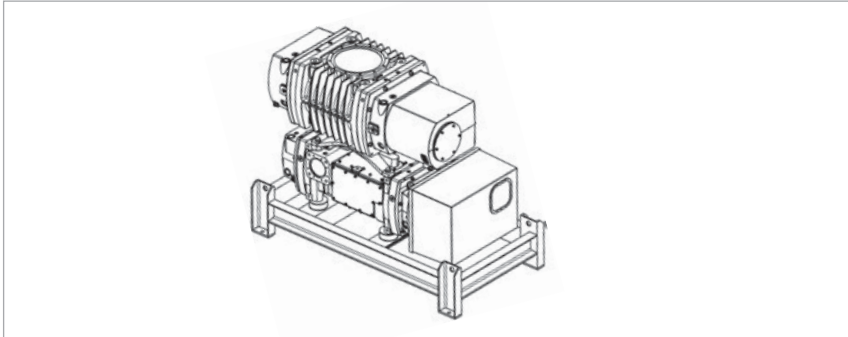

RUTA WH4400/DV650/A

Standard Equipment

- RUVAC WH and DRYVAC with water cooling
- DRYVAC DV with built-in frequency converter
- DRYVAC DV-r including external frequency converter
- RUVAC WH including external frequency converter (frequency converter permits pumping speed control)
- Hermetically sealed
- Integrated protection functions (discharge pressure, temperatures and current consumption)

- Innovative motor design with efficiency class IE2
- Gas ballast with manual valve
- Leak detection port
- Lubricant: synthetic oil (LVO 210)

Options

- Exhaust silencer
- Bus interface
- Non-return valve for DRYVAC

- Seal gas connection
- Gear chamber evacuation RUVAC WH
- Frequency converter for RUVAC pump
- Electrical controller
- Oil drain tap
- Cooling water monitoring
- Quick couplings for water connections, blocking on both sides
- Frame

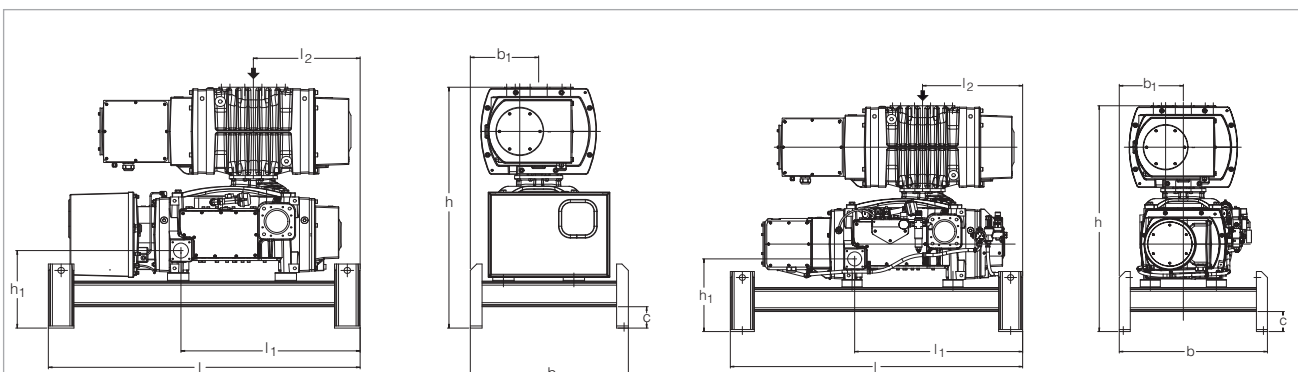

Type	RUTA	WH4400/DV650/A	WH4400/DV650-r/A
RUVAC WH	P2	4400	4400
Backing pump DRYVAC DV	P1	650	650-r
	DN ₁	250 ISO-K	250 ISO-K
	DN ₂	100 ISO-K	100 ISO-K
	l	1460 (57.48)	1460 (57.48)
	l ₁	839 (33.03)	839 (33.03)
	l ₂	500 (19.69)	500 (19.69)
	b	740 (29.13)	740 (29.13)
	b ₁	320 (12.60)	320 (12.60)
	c	100 (3.94)	100 (3.94)
	h	1128 (44.41)	1128 (44.41)
	h ₁	363 (14.29)	363 (14.29)

Dimensional drawing of the pump system with dry compressing DRYVAC DV 650 (left) and DV 650-r (right) backing pump, adaptor version; dimensions in brackets () are in inch

Technical Data, 50 Hz

RUTA WH

4400/DV650/A

4400/DV650-r/A

RUVAC WH	P2	4400	4400
Backing pump DRYVAC DV	P1	650	650-r
Pumping speed, 50 Hz at 10^{-1} mbar (7.5×10^{-2} Torr)	$\text{m}^3 \times \text{h}^{-1}$ (cfm)	3400 (2000)	3400 (2000)
Ultimate total pressure without gas ballast	mbar (Torr)	$< 5.0 \cdot 10^{-4}$ (3.8×10^{-4})	$< 5.0 \cdot 10^{-4}$ (3.8×10^{-4})
Installed motor power 400 V, 50 Hz	kW (hp)	26.0 (34.9)	26.0 (34.9)
Electrical power consumption at 10^{-1} mbar (7.5×10^{-2} Torr)	kW (hp)	9.3 (12.5)	9.3 (12.5)
Noise level with silencer at 10^{-1} mbar (7.5×10^{-2} Torr)	dB(A)	< 68	< 68
Weight, total, approx.	kg (lbs)	1550 (3417)	1550 (3417)
Connecting flange			
Inlet port	DN ₁	250 ISO-K	250 ISO-K
Outlet port	DN ₂	100 ISO-K	100 ISO-K

Ordering Information

RUTA WH

4400/DV650/A

4400/DV650-r/A

		Part No.	Part No.
RUVAC WH	P2	4400	4400
Backing pump DRYVAC DV	P1	650	650-r
Pump system, complete (adaptor version), pallet mounted, with Roots vacuum pump RUVAC WH		503 166 V001 ¹⁾	503 167 V001 ¹⁾

¹⁾ Including external frequency converter

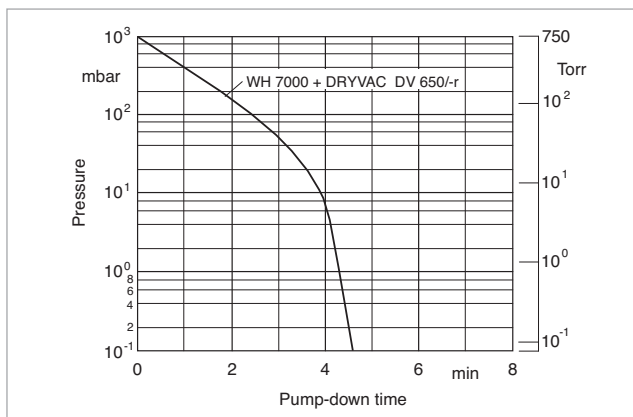

Pump-down time diagram for a 10 m^3 tank at 50 Hz

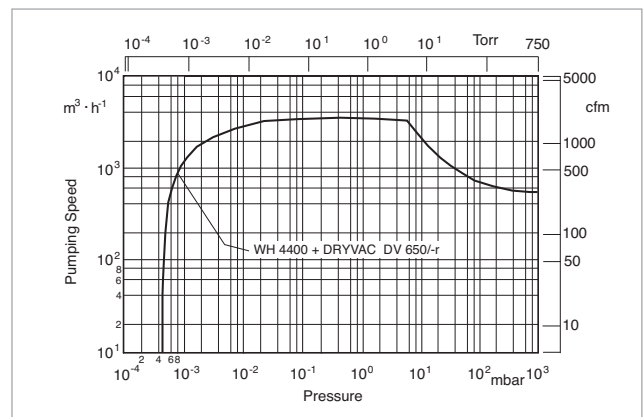

Pumping speed diagram at 50 Hz

Dry Compressing Vacuum Pump System RUTA with DRYVAC DV 650 Backing Pump, Frame Version

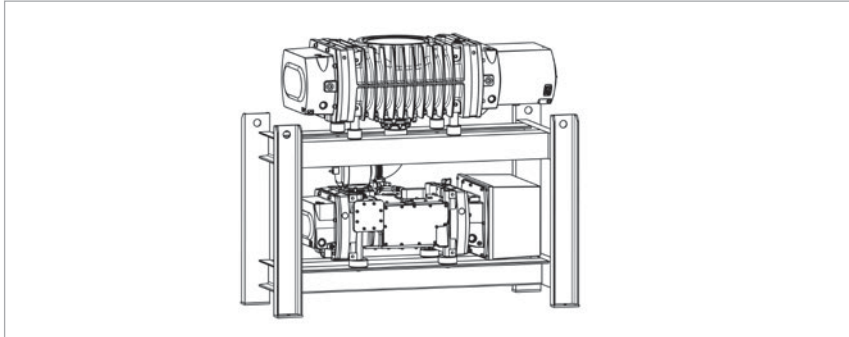

RUTA WH7000/DV650/G

Standard Equipment

- RUVAC WH and DRYVAC with water cooling
- DRYVAC DV with built-in frequency converter
- DRYVAC DV-r including external frequency converter
- RUVAC WH including external frequency converter (frequency converter permits pumping speed control)
- Hermetically sealed
- Integrated protection functions (discharge pressure, temperatures and current consumption)
- Innovative motor design with efficiency class IE2
- Gas ballast with manual valve
- Leak detection port
- Lubricant: synthetic oil (LVO 210)
- SECUVAC valve 24 V DC
- Gear chamber evacuation RUVAC WH
- Electrical controller
- Oil drain tap
- Cooling water monitoring
- Quick couplings for water connections, blocking on both sides

Options

- Exhaust silencer
- Bus interface
- Non-return valve for DRYVAC
- Seal gas connection

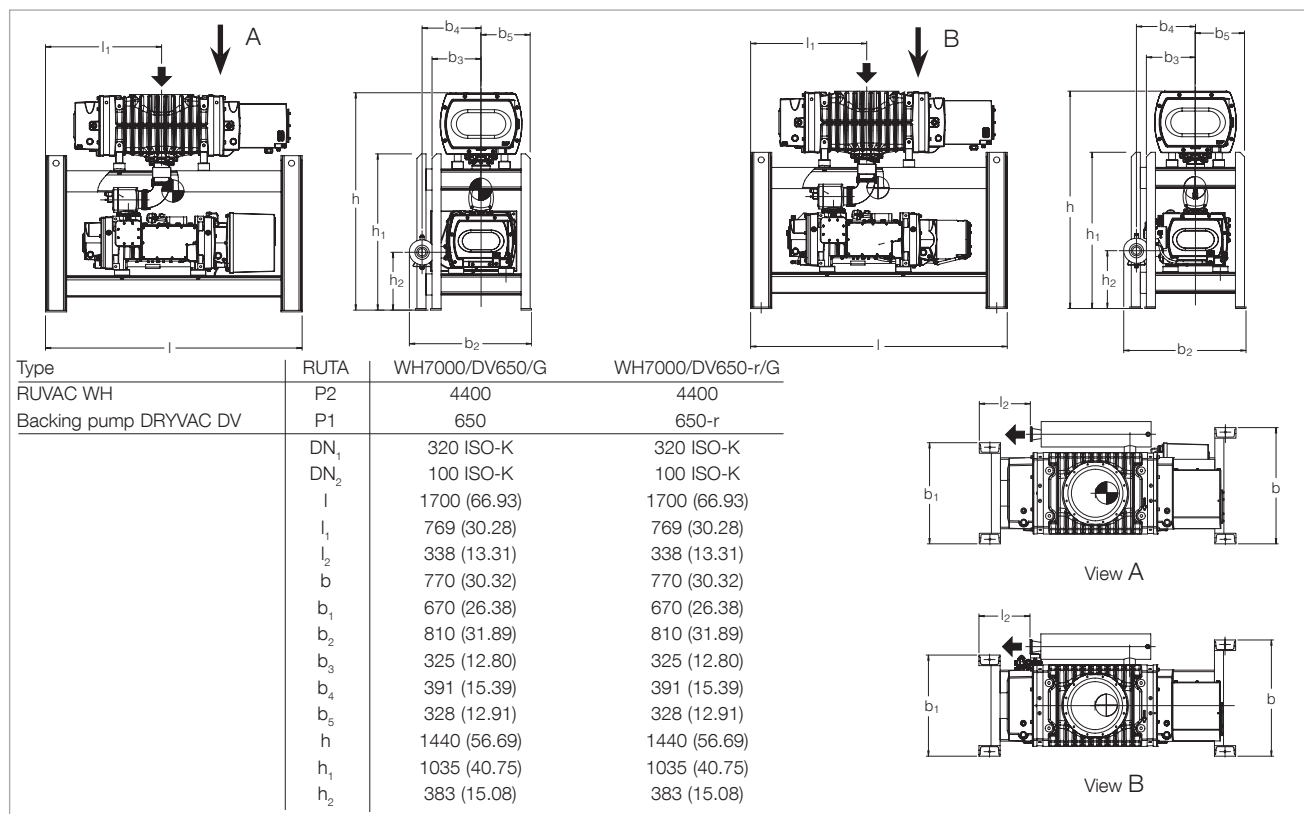

Dimensional drawing of the pump system with dry compressing DRYVAC DV 650 (left) and DV 650-r (right) backing pump, frame version; dimensions in brackets () are in inch; (shown with optional silencer)

Technical Data, 50 Hz

RUTA WH

7000/DV650/G

7000/DV650-r/G

RUVAC WH	P2	7000	7000
Backing pump DRYVAC DV	P1	650	650-r
Pumping speed, 50 Hz at 10^{-1} mbar (7.5×10^{-2} Torr)	$\text{m}^3 \times \text{h}^{-1}$ (cfm)	5100 (3001)	5100 (3001)
Ultimate total pressure without gas ballast	mbar (Torr)	$< 5.0 \cdot 10^{-4}$ (3.8×10^{-4})	$< 5.0 \cdot 10^{-4}$ (3.8×10^{-4})
Installed motor power 400 V, 50 Hz	kW (hp)	26.0 (34.9)	26.0 (34.9)
Electrical power consumption at 10^{-1} mbar (7.5×10^{-2} Torr)	kW (hp)	9.36 (12.56)	9.36 (12.56)
Noise level with silencer at 10^{-1} mbar (7.5×10^{-2} Torr)	dB(A)	< 68	< 68
Weight, total, approx.	kg (lbs)	1600 (3527)	1600 (3527)
Connecting flange			
Inlet port	DN ₁	320 ISO-K	320 ISO-K
Outlet port	DN ₂	100 ISO-K	100 ISO-K

Ordering Information

RUTA WH

7000/DV650/G

7000/DV650-r/G

		Part No.	Part No.
RUVAC WH	P2	7000	7000
Backing pump DRYVAC DV	P1	650	650-r
Pump system, complete (adaptor version), frame mounted, with Roots vacuum pump RUVAC WH		503 170 V001 ¹⁾	503 171 V001 ¹⁾

¹⁾ Including external frequency converter

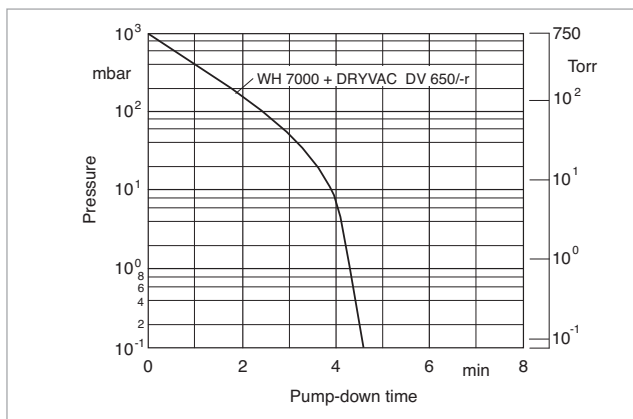

Pump-down time diagram for a 10 m^3 tank at 50 Hz

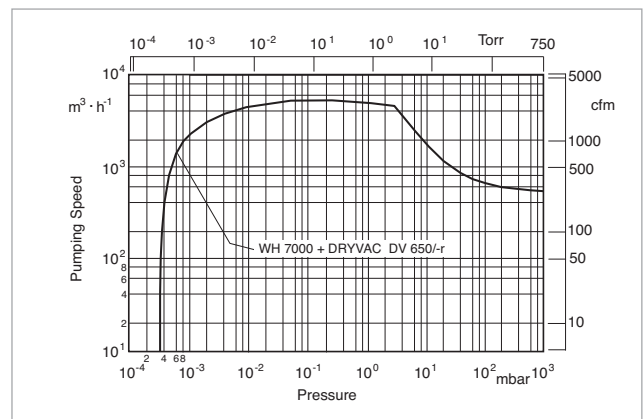

Pumping speed diagram at 50 Hz

Dry Compressing Vacuum Pump System RUTA with DRYVAC DV 1200 Backing Pump, Frame Version

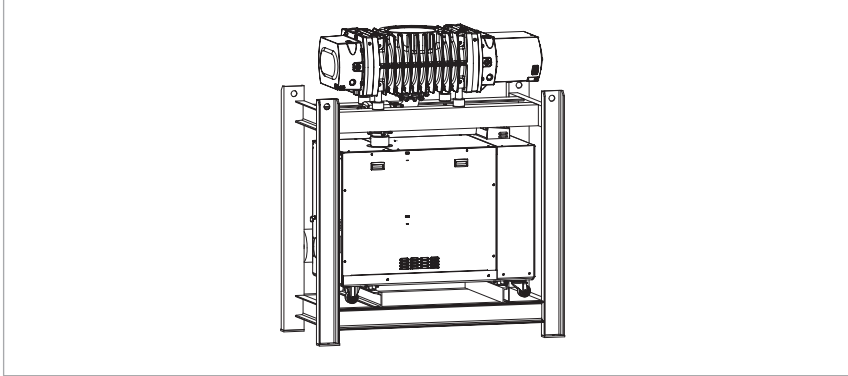

RUTA WH7000/DV1200/G

Standard Equipment

- RUVAC WH and DRYVAC with water cooling
- DRYVAC DV 1200 with built-in frequency converter
- RUVAC WH with water cooling and external frequency converter
- Hermetically sealed
- Integrated protection functions (discharge pressure, temperatures and current consumption)
- Innovative motor design with efficiency class IE2
- Gas ballast with electropneumatic valve 24 V DC
- Integrated valve 24 V DC for seal gas supply
- Leak detection port
- Control via Profibus (DRYVAC)
- Lubricant: synthetic oil (LVO 210)

Options

- Exhaust silencer
- Bus interface
- Non-return valve for DRYVAC
- Seal gas connection
- Gear chamber evacuation
- Electrical controller
- Oil drain tap
- Cooling water monitoring
- Quick couplings for water connections, blocking on both sides

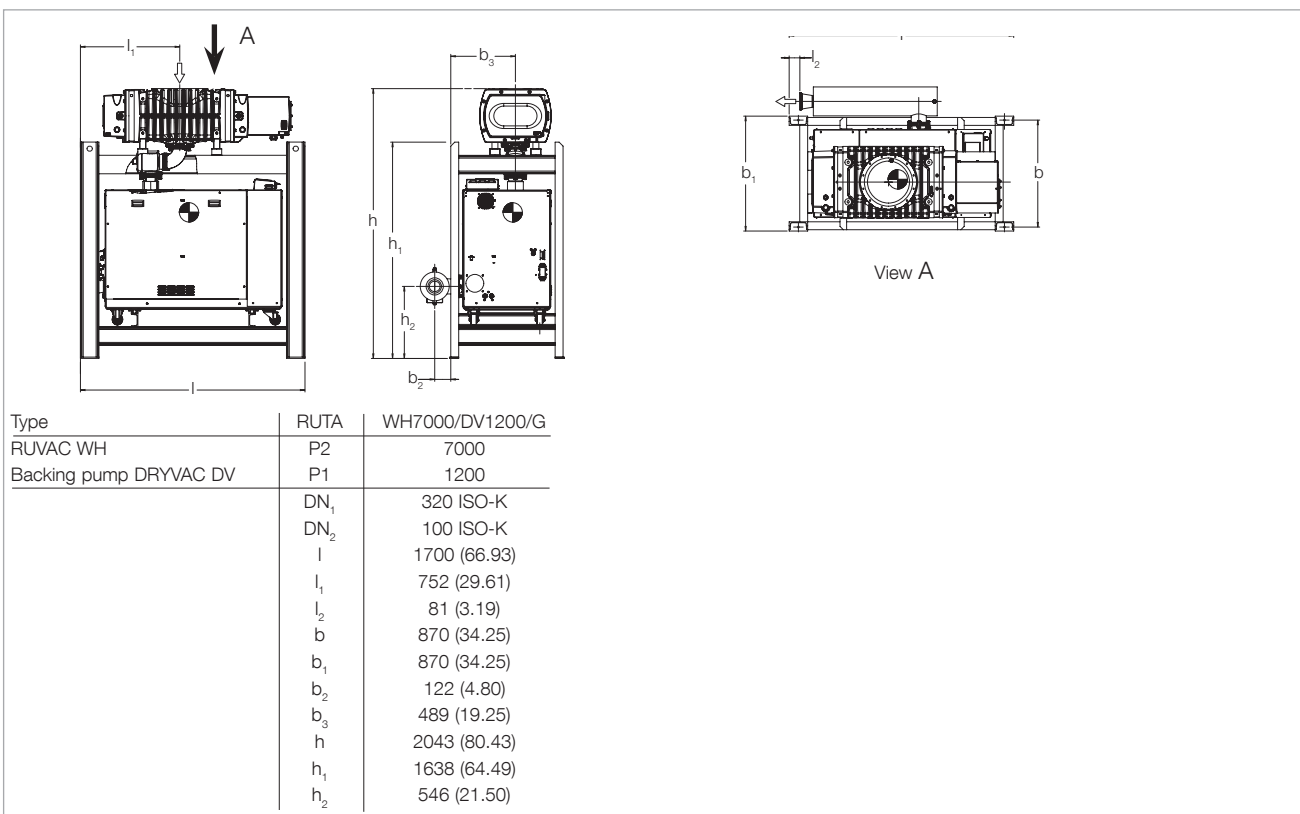

Dimensional drawing of the pump system with dry compressing DRYVAC DV 1200, frame version; dimensions in brackets () are in inch

Technical Data, 50 Hz

RUTA WH 7000/DV1200/G

RUVAC WH	P2	7000
Backing pump DRYVAC DV	P1	1200
Pumping speed, 50 Hz at 10^{-1} mbar (7.5×10^{-2} Torr)	$\text{m}^3 \times \text{h}^{-1}$ (cfm)	5537 (3259)
Ultimate total pressure without gas ballast	mbar (Torr)	$< 6.0 \times 10^{-4}$ (4.5×10^{-4})
Installed motor power 400 V, 50 Hz	kW (hp)	41.0 (55)
Electrical power consumption at 10^{-1} mbar (7.5×10^{-2} Torr)	kW (hp)	16.2 (21.7)
Noise level with silencer at 10^{-1} mbar (7.5×10^{-2} Torr)	dB(A)	< 68
Weight, total, approx.	kg (lbs)	2450 (5410)
Connecting flange		
Inlet port	DN ₁	320 ISO-K
Outlet port	DN ₂	100 ISO-K

Ordering Information

RUTA WH 7000/DV1200/G

		Part No.
RUVAC WH	P2	7000
Backing pump DRYVAC DV	P1	1200
Pump system, complete (adaptor version), frame mounted, with Roots vacuum pump RUVAC WH		503 172 V001 ¹⁾

¹⁾ Including external frequency converter

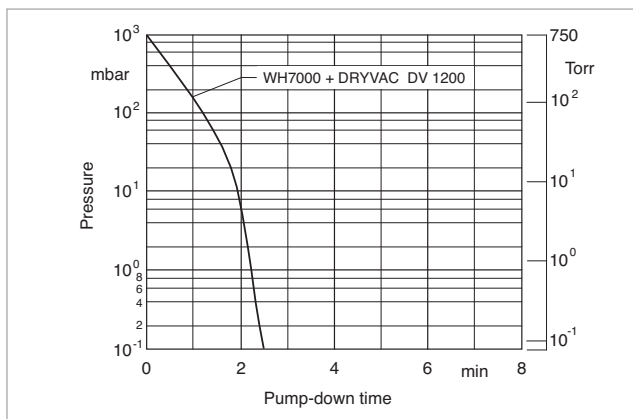

Pump-down time diagram for a 10 m^3 tank at 50 Hz

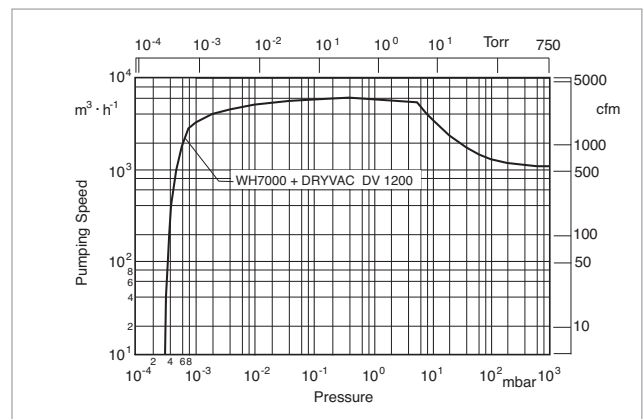

Pumping speed diagram at 50 Hz

DRYVAC Load Lock Pump Systems Adaptor Version

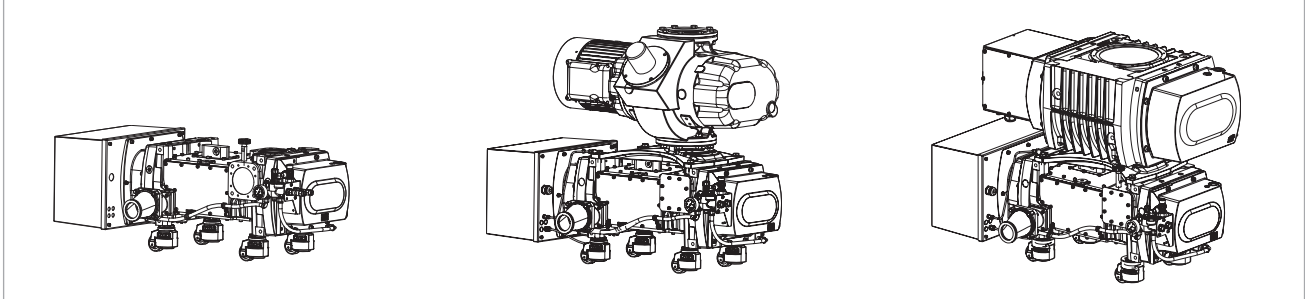

DRYVAC load lock pump system RUTA DV650S (left), RUTA WSU2001/DV650S/A (middle) and RUTA WHU4400/DV650S/A (right)

Standard Equipment

- DRYVAC DV S and RUVAC WHU with water cooling
- RUVAC WSU with air cooling
- Rollable pump system with locking foot
- Hermetically sealed
- Integrated protection functions (discharge pressure, temperatures and current consumption)
- Relay module (digital I/O)
- Non-return valve

- Leak detection port
- Lubricant: synthetic oil (LVO 400/410)

Options

- Exhaust silencer
- Bus interface
- Seal gas connection
- Gear chamber evacuation

- RUVAC WAU
- Frequency converter for RUVAC pump
- Electrical controller
- Oil drain valve
- Cooling water monitoring
- Quick couplings for water connections, blocking on both sides
- Frame

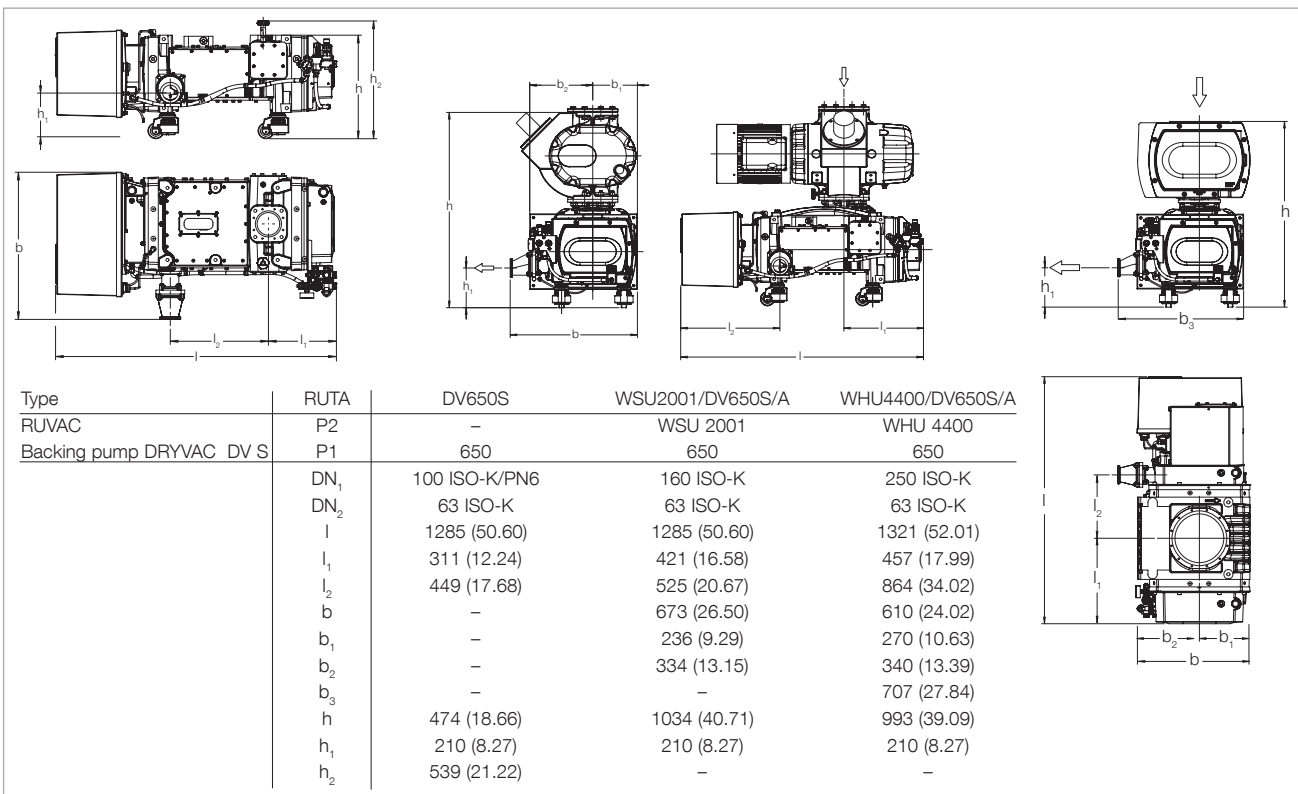

Dimensional drawing of the load lock pump systems with dry compressing DRYVAC backing pump, adaptor version: RUTA DV650S (left), RUTA WSU2001/DV650S/A (middle) and RUTA WHU4400/DV650S/A (right); dimensions in brackets () are in inch

Technical Data

RUTA

		DV650S	WSU2001/DV650S/A	WHU4400/DV650S/A
RUVAC WSU/WHU (WAU possible)	P2	–	WSU 2001	WHU 4400
Backing pump DRYVAC DV S on castors	P1	650	650	650
Pumping speed, 50 Hz at 10 ⁻¹ mbar (7.5 x 10 ⁻² Torr)	m ³ x h ⁻¹ (cfm)	520 (306)	1760 (1036)	3400 (2000)
Ultimate total pressure without gas ballast	mbar (Torr)	< 5.0 x 10 ⁻³ (3.75 x 10 ⁻⁴)	< 5.0 x 10 ⁻³ (3.75 x 10 ⁻⁴)	< 5.0 x 10 ⁻³ (3.75 x 10 ⁻⁴)
Installed motor power, 3-ph. 380-480 V, 50/60 Hz	kW (hp)	15.0 (20.4)	–	–
400-460 V, 50/60 Hz	kW (hp)	–	22.5 (30.6)	33.5 (45.6)
Electrical power consumption at 10 ⁻¹ mbar (7.5 x 10 ⁻² Torr)	kW (hp)	6.9 (9.4)	8.4 (11.4)	9.3 (12.6)
Noise level with permanently attached exhaust line at ultimate total pressure	dB(A)	65	70	70
Operating agent	LVO	410	400 / 410	400 / 410
Total oil filling, approx.	l (imp qt)	1.2 (1.05)	4.2 (3.0 / 1.2) 3.65 (2.6 / 1.05)	5.95 (4.75 / 1.2) 5.25 (4.2 / 1.05)
Total weight, approx.	kg (lbs)	590 (1300)	1100 (2425)	1350 (2976)
Permissible ambient temperature	°C	+5 to +50	+12 to +40	+10 to +40
Connecting flange				
Inlet port				
top	1 x DN ₁	100 ISO-K	160 ISO-K	250 ISO-K
side	2 x DN ₁	PN6	–	–
Outlet port	DN ₂	63 ISO-K	63 ISO-K	63 ISO-K

Ordering Information

RUTA

		DV650S	WSU2001/DV650S/A	WHU4400/DV650S/A
RUVAC WSU/WHU	P2	–	WSU 2001	WHU 4400
Backing pump DRYVAC DV S on castors	P1	650	650	650
Load lock pump system, complete (adaptor version) with Roots vacuum pump RUVAC		503 261 V001	503 255 V001	503 256 V001

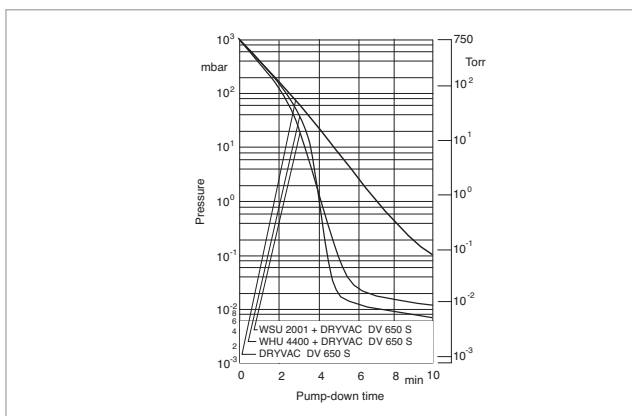

Pump-down time diagram for a 10 m³ tank at 50 Hz

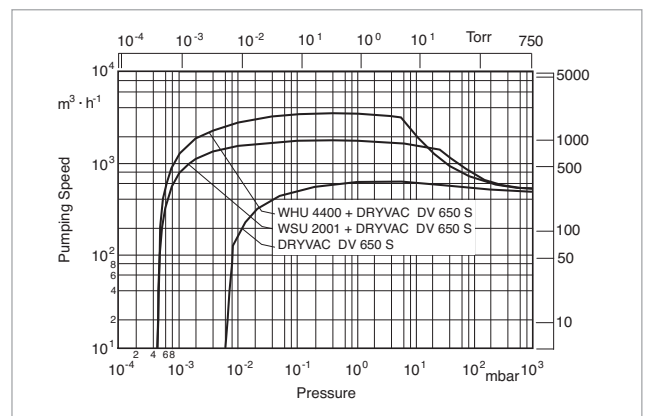

Pumping speed diagram at 50 Hz

DRYVAC Process Pump Systems Adaptor Version

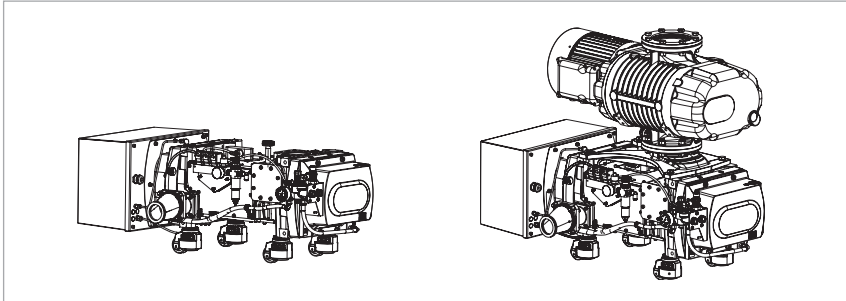

DRYVAC process pump system RUTA DV650C (left) and RUTA WS2001/DV650C/A (right)

Standard Equipment

- DRYVAC DV C with water cooling
- RUVAC WS with air cooling
- Rollable pump system with locking foot
- Hermetically sealed
- Seal gas module, threefold
- Integrated protection functions (discharge pressure, temperatures and current consumption)
- Relay module (digital I/O)
- Non-return valve
- Leak detection port
- Lubricant: synthetic oil (LVO 400/410)

Options

- Exhaust silencer
- Bus interface
- Gear chamber evacuation
- Electrical controller
- Oil drain valve
- Cooling water monitoring
- Quick couplings for water connections, blocking on both sides
- Frame

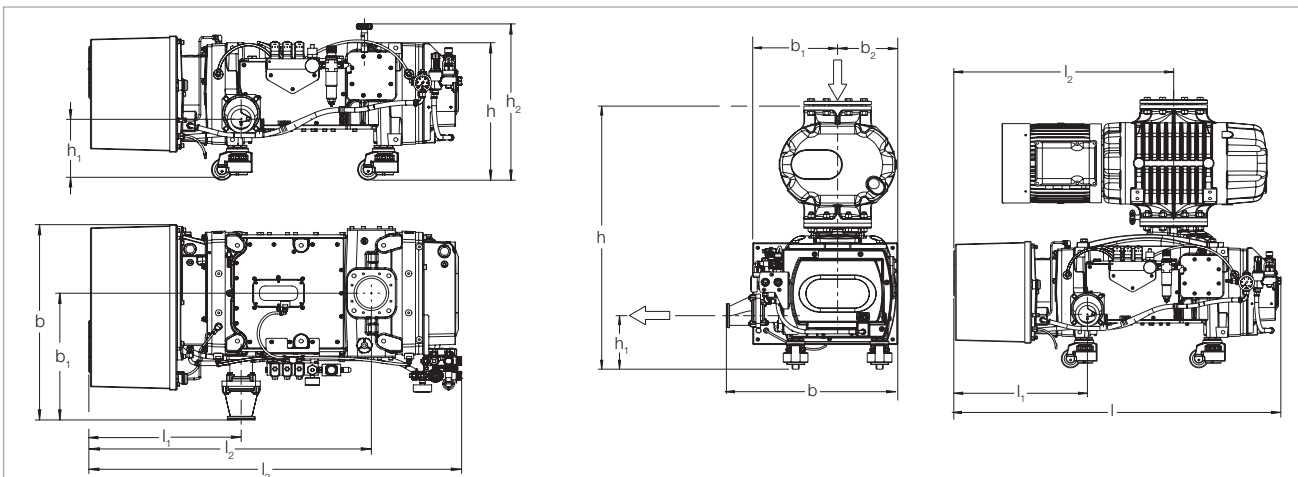

Type	RUTA	DV650C	WS2001/DV650C/A
RUVAC	P2	-	WS 2001
Backing pump DRYVAC DV C	P1	650	650
DN ₁		100 ISO-K/PN6	160 ISO-K
DN ₂		63 ISO-K	63 ISO-K
l		1285 (50.60)	1285 (50.60)
l ₁		525 (20.67)	864 (34.02)
l ₂		974 (38.35)	525 (20.67)
b		673 (26.50)	673 (26.50)
b ₁		437 (17.21)	133 (5.24)
b ₂		-	236 (9.29)
h		474 (18.66)	1034 (40.71)
h ₁		210 (8.27)	210 (8.27)
h ₂		539 (21.22)	-

Dimensional drawing of the process pump systems with dry compressing DRYVAC backing pump, adaptor version: RUTA DV650C (left) and RUTA WS2001/DV650C/A (right); dimensions in brackets () are in inch

Technical Data

RUTA

DV650C

WS2001/DV650C/A

RUVAC WS	P2	–	2001
Backing pump DRYVAC DV C on castors	P1	650	650
Pumping speed, 50 Hz at 10^{-1} mbar (7.5×10^{-2} Torr)	$\text{m}^3 \times \text{h}^{-1}$ (cfm)	520 (306)	1760 (1036)
Ultimate total pressure without gas ballast	mbar (Torr)	$< 5 \times 10^{-3}$ (3.75×10^{-3})	$< 5 \times 10^{-4}$ (3.75×10^{-4})
Installed motor power, 3-ph. 380-480 V, 50/60 Hz	kW (hp)	15.0 (20.4)	–
400-460 V, 50/60 Hz	kW (hp)	–	22.5 (30.6)
Electrical power consumption at 10^{-1} mbar (7.5×10^{-2} Torr)	kW (hp)	6.9 (9.4)	8.4 (11.4)
Noise level with permanently attached exhaust line at ultimate total pressure	dB(A)	65	70
Operating agent	LVO	410	400/410
Total oil filling, approx.	l (imp qt)	1.2 (1.05)	4.2 (3.0/1.2) 3.65 (2.6 / 1.05)
Total weight, approx.	kg (lbs)	590 (1300)	1100 (2425)
Permissible ambient temperature	°C	+5 to +50	+12 to +40
Connecting flange Inlet port			
top	1 x DN ₁	100 ISO-K	160 ISO-K
side	2 x DN ₁	PN6	–
Outlet port	DN ₂	63 ISO-K	63 ISO-K

Ordering Information

RUTA

DV650C

WS2001/DV650C/A

		Part No.	Part No.
RUVAC WS	P2	–	2001
Backing pump DRYVAC DV C on castors	P1	650	650
Process pump system, complete (adaptor version) with Roots vacuum pump RUVAC		503 262 V001	503 263 V001

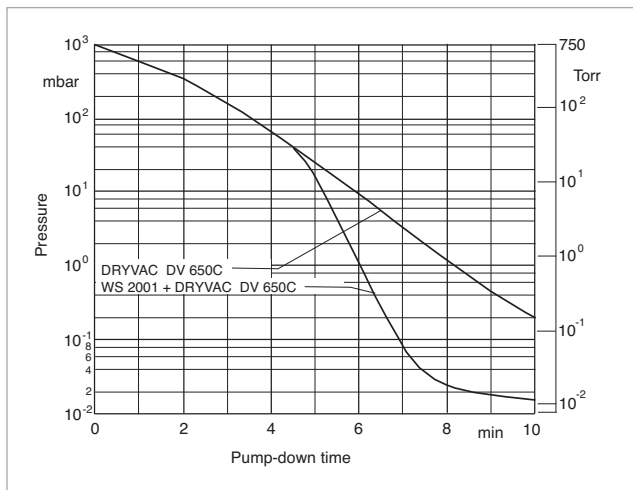

Pump-down time diagram for a 10 m³ tank at 50 Hz

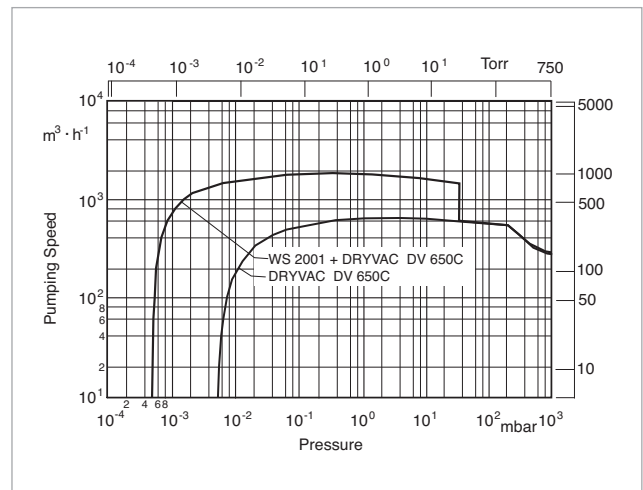

Pumping speed diagram at 50 Hz

DRYVAC Process Pump Systems with RUVAC WH Backing Pump Adaptor Version

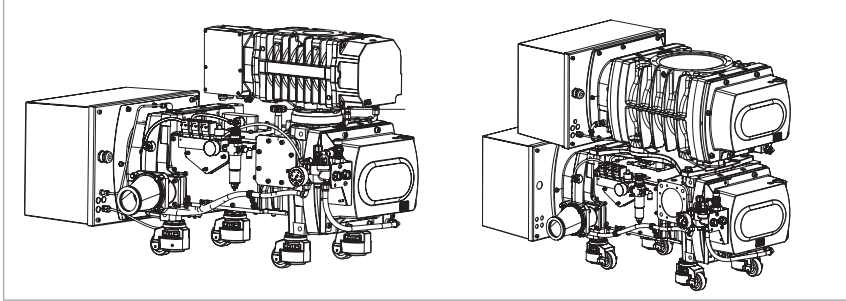

DRYVAC process pump system RUTA WH700FU/DV650C/A (left) and RUTA WH2500/DV650C/A (right)

Standard Equipment

- DRYVAC DV C and RUVAC WH with water cooling
- Rollable pump system with locking foot
- Hermetically sealed
- Seal gas module, threefold
- Integrated protection functions (discharge pressure, temperatures and current consumption)

- Relay module (digital I/O)
- Non-return valve
- Leak detection port
- Lubricant: synthetic oil (LVO 400/410)

Options

- Exhaust silencer
- Bus interface
- Gear chamber evacuation
- Electrical controller
- Oil drain valve
- Cooling water monitoring
- Quick couplings for water connections, blocking on both sides
- Frame

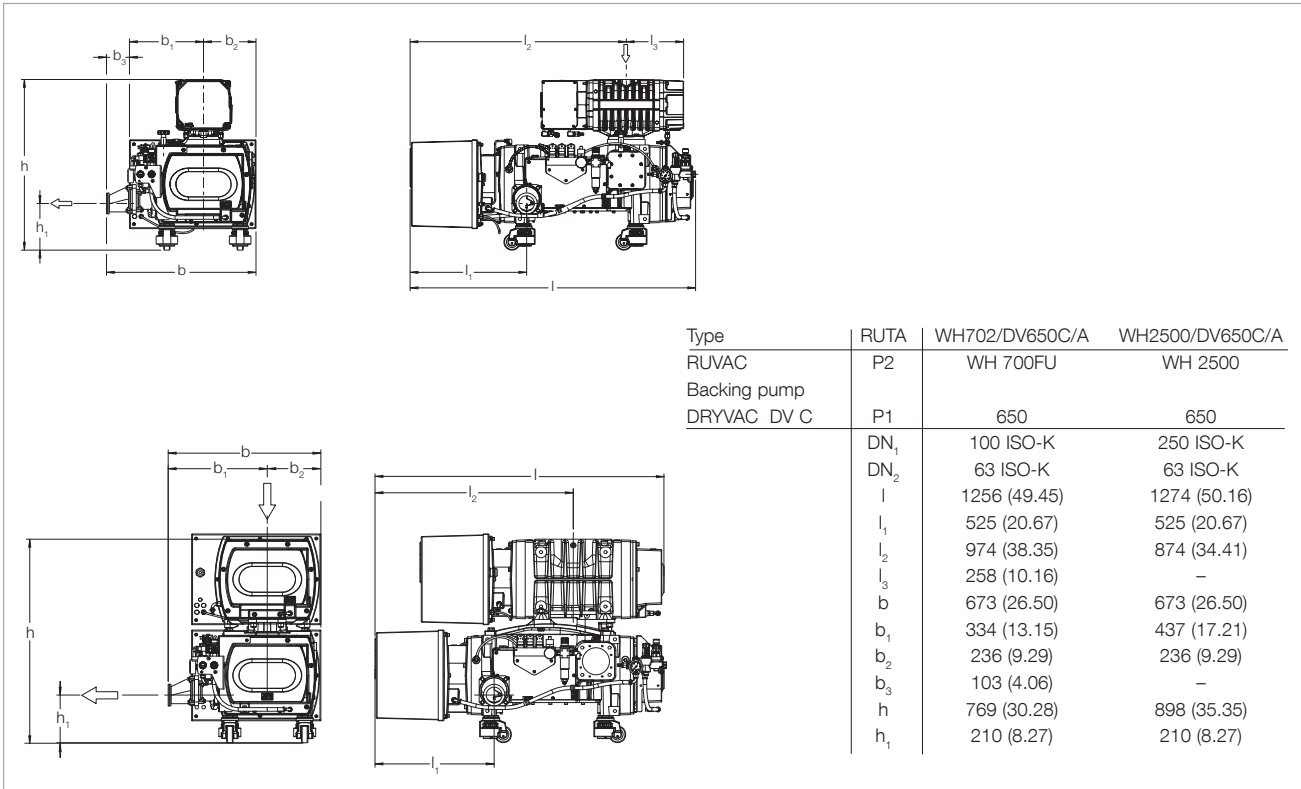

Dimensional drawing of the process pump systems with dry compressing DRYVAC backing pump, adaptor version: RUTA WH700FU/DV650C/A (top) and RUTA WH2500/DV650C/A (below); dimensions in brackets () are in inch

Technical Data

RUTA WH

700FU/DV650C/A

2500/DV650C/A

RUVAC WH	P2	700FU	2500
Backing pump DRYVAC DV C on castors	P1	650	650
Pumping speed, 50 Hz at 10^{-1} mbar (7.5×10^{-2} Torr)	$\text{m}^3 \times \text{h}^{-1}$ (cfm)	1220 (718)	3115 (1834)
Ultimate total pressure without gas ballast	mbar (Torr)	$< 6 \times 10^{-4}$ (4.5×10^{-4})	$< 5 \times 10^{-4}$ (3.75×10^{-4})
Installed motor power, 3-ph. 380-480 V, 50/60 Hz	kW (hp)	17.2 (23.4)	–
400-460 V, 50/60 Hz	kW (hp)	–	21.2 (28.8)
Electrical power consumption at 10^{-1} mbar (7.5×10^{-2} Torr)	kW (hp)	7.4 (10.1)	8.6 (11.7)
Noise level with permanently attached exhaust line at ultimate total pressure	dB(A)	70	70
Operating agent	LVO	400/410	410
Total oil filling, approx.	l (imp qt)	2.1 (0.9/1.2) 1.9 (0.8/11)	2.4 (1.2/1.2) 2.1 (1.05/1.05)
Total weight, approx.	kg (lbs)	800 (1764)	1100 (2425)
Permissible ambient temperature	°C	+12 to +50	+10 to +50
Connecting flange Inlet port			
top	1 x DN ₁	100 ISO-K	250 ISO-K
side	2 x DN ₁	–	–
Outlet port	DN ₂	63 ISO-K	63 ISO-K

Ordering Information

RUTA WH

700FU/DV650C/A

2500/DV650C/A

		Part No.	Part No.
RUVAC WH	P2	700FU	2500
Backing pump DRYVAC DV C on castors	P1	650	650
Process pump system, complete (adaptor version) with Roots vacuum pump RUVAC		503 257 V001	503 258 V001

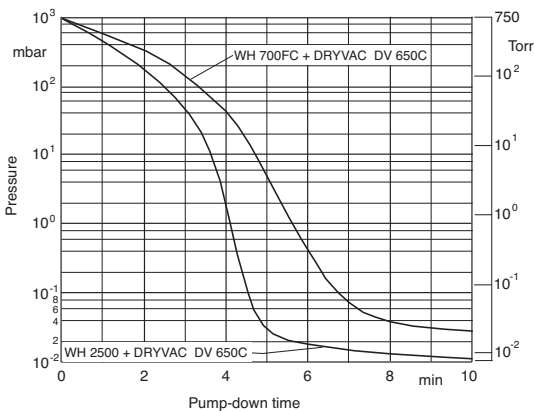

Pump-down time diagram for a 10 m³ tank at 50 Hz

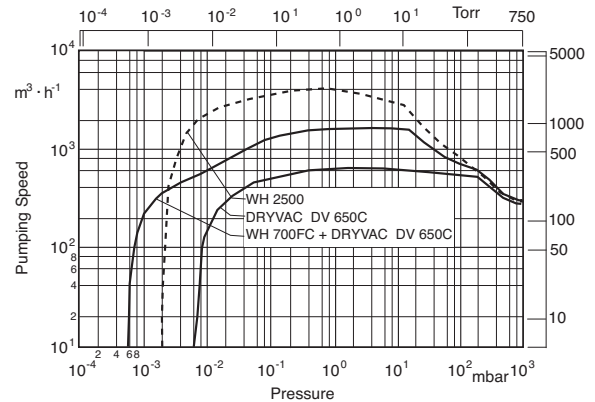

Pumping speed diagram at 50 Hz

DRYVAC Pump Systems, enclosed Adaptor Version

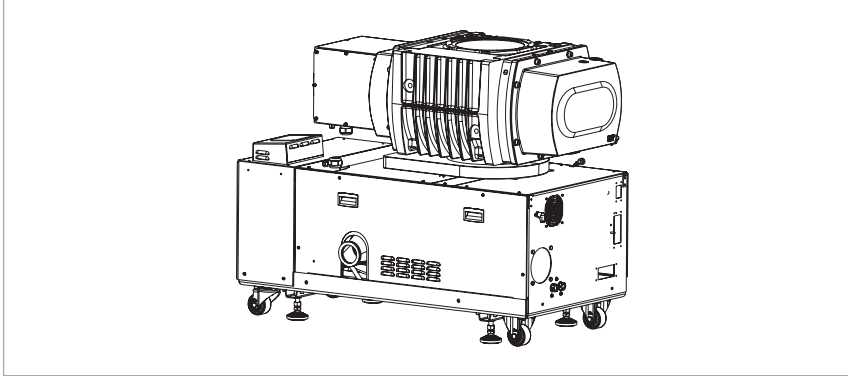

RUTA WHU4400/DV650S-i/A/E

Standard Equipment

- DRYVAC DV S and RUVAC WHU with water cooling
- Pump system partly enclosed and electrically prewired
- With integrated PLC (Part No. 503259V001)
- Pumps independently electrically controllable (Part No. 503260V001)
- Hermetically sealed
- Integrated protection functions (discharge pressure, temperatures and current consumption)

- Relay module (digital I/O)
- Non-return valve
- Leak detection port
- Lubricant: synthetic oil (LVO 400/410)

Options

- RUVAC WS / WSU / WH
- Exhaust silencer
- Bus interface

- Seal gas connection
- Gear chamber evacuation
- Frequency converter for RUVAC pump
- Oil drain valve
- Cooling water monitoring
- Quick couplings for water connections, blocking on both sides
- Housing suction facility

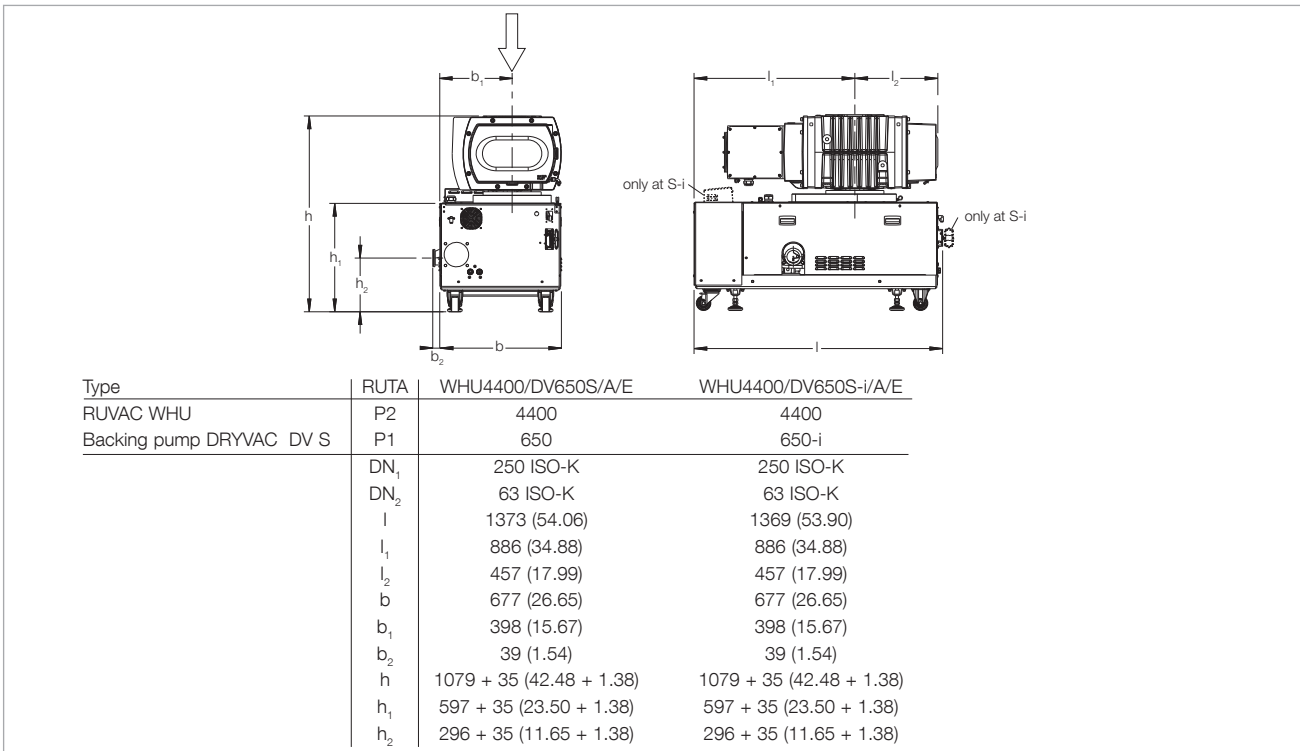

Dimensional drawing of the enclosed pump systems with DRYVAC DV650S(-i) backing pumps; dimensions in brackets () are in inch

Technical Data

RUTA WHU

4400/DV650S/A/E

4400/DV650S-i/A/E

RUVAC WHU (WH possible)	P2	4400	4400
Backing pump DRYVAC DV S with enclosure, silencer, castors and additional PLC	P1 P1	650 -	- 650-i
Pumping speed, 50 Hz at 1×10^{-1} mbar (7.5×10^{-2} Torr)	$\text{m}^3 \times \text{h}^{-1}$ (cfm)	3400 (2000)	3400 (2000)
Ultimate total pressure without gas ballast	mbar (Torr)	$< 5.0 \times 10^{-3}$ (3.75×10^{-3})	$< 5.0 \times 10^{-3}$ (3.75×10^{-3})
Installed motor power, 3-ph. 400-460 V, 50/60 Hz	kW (hp)	33.5 (45.6)	33.5 (45.6)
Electrical power consumption at 1×10^{-1} mbar (7.5×10^{-2} Torr)	kW (hp)	9.3 (12.6)	9.3 (12.6)
Noise level with permanently attached exhaust line at ultimate total pressure	dB(A)	70	70
Operating agent	LVO	400/410	400/410
Total oil filling, approx.	l (imp qt)	5.95 (4.75/1.2) 5.25 (4.2/1.05)	5.95 (4.75/1.2) 5.25 (4.2/1.05)
Total weight, approx.	kg (lbs)	1350 (2976)	1350 (2976)
Permissible ambient temperature	°C	+10 to +40	+10 to +40
Connecting flange Inlet port Outlet port	DN ₁ DN ₂	250 ISO-K 63 ISO-K	250 ISO-K 63 ISO-K

Ordering Information

RUTA WHU

4400/DV650S/A/E

4400/DV650S-i/A/E

		Part No.	Part No.
RUVAC WHU (WH possible)	P2	4400	4400
Backing pump DRYVAC DV S	P1	650	650-i
Enclosed pump system, complete (adaptor version) with Roots vacuum pump RUVAC		503 260 V001	503 259 V001

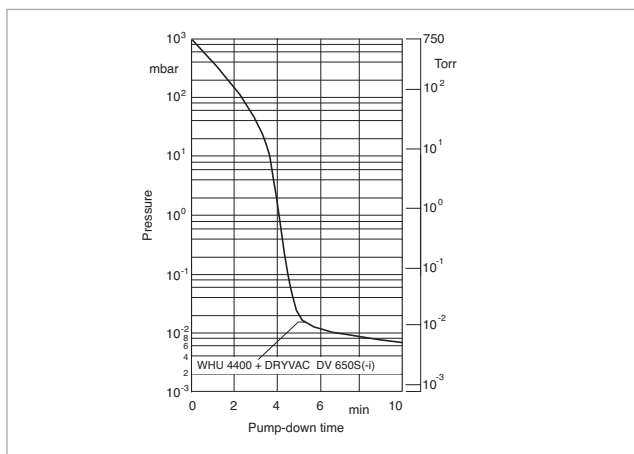

Pump-down time diagram for a 10 m³ tank at 50 Hz

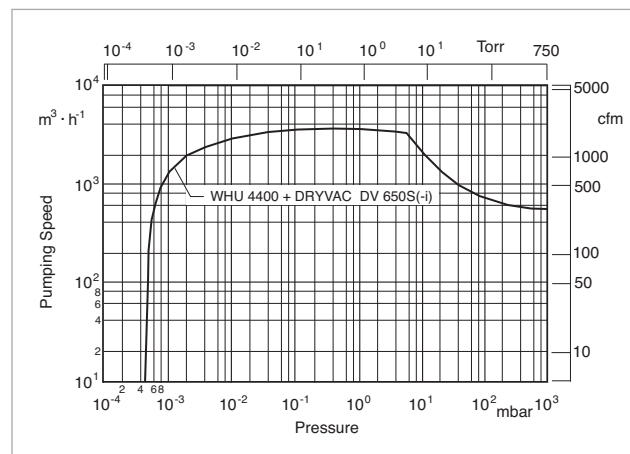

Pumping speed diagram at 50 Hz

RUVAC RAV Roots Vacuum Pumps with Pre-Admission Cooling

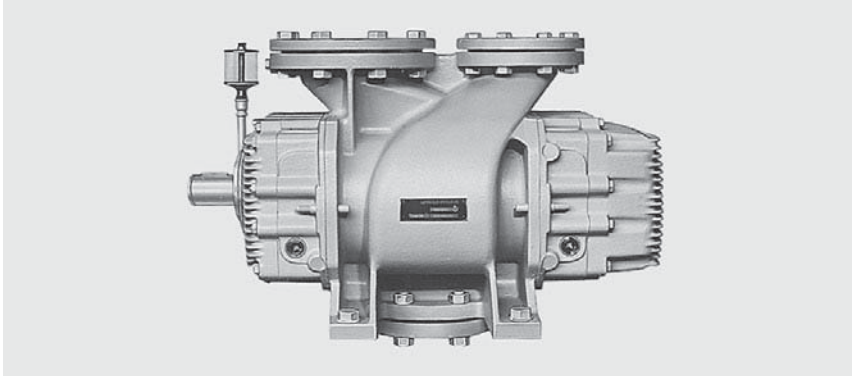

Typical Applications

- Short pump-down cycles on large volumes
- Oil-free compression of high volume flows of gases and vapors against atmospheric pressure
- Single-stage (G) or in combination with RAV F as backing pump
- Operating pressures in the rough vacuum range
- CE approval

Advantages to the User

- **RUVAC RAV G**
Operating pressure range of 150 mbar (112.5 Torr) against atmospheric pressure; total leak rate $< 10^{-1}$ mbar x l x s⁻¹ (7.5×10^{-2} Torr x l x s⁻¹)
- **RUVAC RAV F**
In combination with backing pumps the attainable operating pressures extend down into the medium vacuum range;
- leak rate $< 10^{-2}$ mbar x l x s⁻¹ (7.5×10^{-3} Torr x l x s⁻¹)
- When series-connected the operating pressures extend down into the medium vacuum range:
 - two-stages to 25 mbar (18.75 Torr)
 - multiple stage to 10^{-3} mbar (7.5×10^{-4} Torr)
- Motors for special supply voltages and frequencies or protected types are available
- Pre-admission silencer and filter for the cooling gas inlet as well as silencers for the exhaust side (option/single-stage)
- Downstream gas cooler (option/multistage)
- C version (chemical version/option)
- Special materials (option)
- Pressure burst resistant version (option)

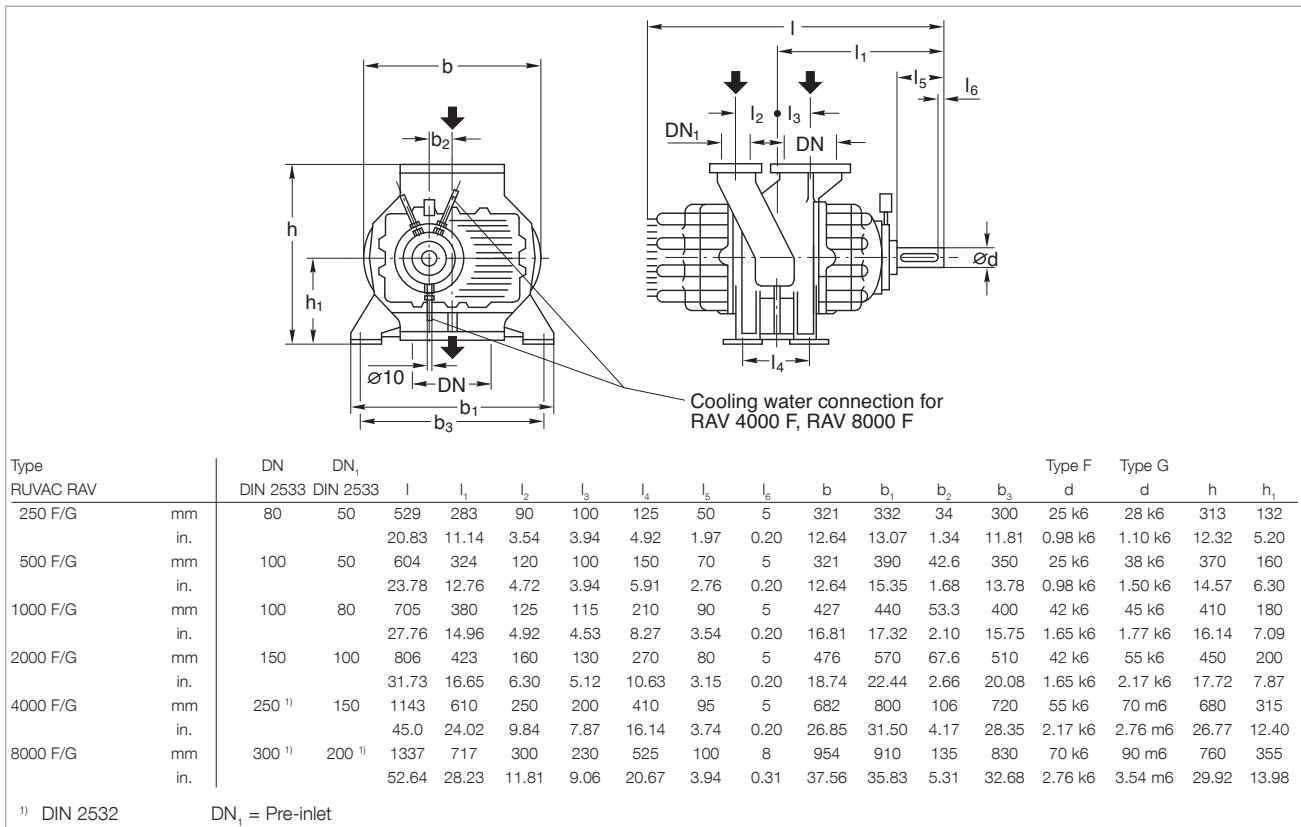

Dimensional drawing for the RUVAC RAV pumps

Technical Data, 50 Hz

		RUVAC RAV					
		250 G	500 G	1000 G	2000 G	4000 G	8000 G
Pumping speed ¹⁾	m ³ x h ⁻¹ (cfm)	250 (147)	500 (295)	1000 (589)	2000 (1178)	3700 (2179)	8100 (4771)
Nominal speed	min ⁻¹ (rpm)	3000 (3000)	3000 (3000)	3000 (3000)	3000 (3000)	1500 (1500)	1500 (1500)
Max. permissible pressure difference ²⁾	mbar (Torr)	850 (637)	850 (637)	850 (637)	850 (637)	850 (637)	850 (637)
Connecting flange	DN	80	100	100	150	250	300
Max. permissible motor power	for direct drive						
	for belt drive						
	kW (hp)	11.0 (15.0)	18.5 (25.2)	30.0 (40.8)	55.0 (74.8)	95.0 (129.3)	200.0 (272.1)
	kW (hp)	11.0 (15.0)	18.5 (25.2)	30.0 (40.8)	55.0 (74.8)	95.0 (129.3)	200.0 (272.1)
Weight	kg (lbs)	95 (210)	160 (353)	225 (496)	310 (684)	720 (1588)	1230 (2712)

Ordering Information

		RUVAC RAV					
		250 G	500 G	1000 G	2000 G	4000 G	8000 G
		Part No.	Part No.	Part No.	Part No.	Part No.	Part No.
Roots vacuum pump RUVAC RAV G		upon request	upon request	upon request	upon request	upon request	upon request

Technical Data, 50 Hz

		RUVAC RAV					
		250 F	500 F	1000 F	2000 F	4000 F	8000 F
Pumping speed ¹⁾	m ³ x h ⁻¹ (cfm)	250 (147)	500 (295)	1000 (589)	2000 (1178)	3700 (2179)	8100 (4771)
Nominal speed	min ⁻¹ (rpm)	3000 (3000)	3000 (3000)	3000 (3000)	3000 (3000)	1500 (1500)	1500 (1500)
Max. permissible pressure difference ²⁾	mbar (Torr)	850 (637)	850 (637)	850 (637)	850 (637)	850 (637)	850 (637)
Connecting flange	DN	80	100	100	150	250	300
Max. permissible motor power	for direct drive						
	for belt drive						
	kW (hp)	11.0 (15.0)	18.5 (25.2)	30.0 (40.8)	55.0 (74.8)	95.0 (129.3)	200.0 (272.1)
	kW (hp)	4.0 (5.4)	4.0 (5.4)	7.5 (10.2)	15.0 (20.4)	37.0 (50.3)	75 (102.0)
Gear oil, approx.	l (qt)	0.9 (0.95)	1.1 (1.6)	1.5 (1.59)	2.5 (2.64)	12.0 (12.68)	11.0 (11.63)
Weight, approx.	kg (lbs)	95 (210)	160 (353)	225 (496)	310 (684)	720 (1588)	1230 (2712)
Cooling water connection, fitting for tube		-	-	-	-	10 x 1	10 x 1
Cooling water requirement, approx.	l x h ⁻¹	-	-	-	-	60	60

Ordering Information

		RUVAC RAV					
		250 F	500 F	1000 F	2000 F	4000 F	8000 F
		Part No.	Part No.	Part No.	Part No.	Part No.	Part No.
Roots vacuum pump RUVAC RAV F		upon request	upon request	upon request	upon request	upon request	upon request

¹⁾ To DIN 28 400 and following numbers

²⁾ RUVAC RAV G and RAV F with direct drive

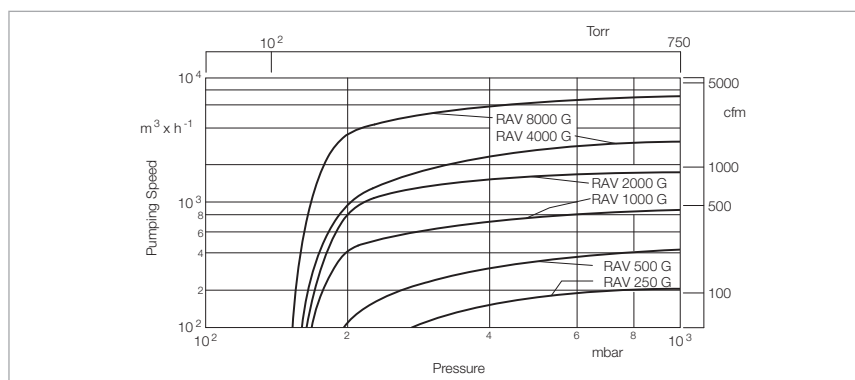

Pumping speed diagram of RUVAC RAV at 50 Hz

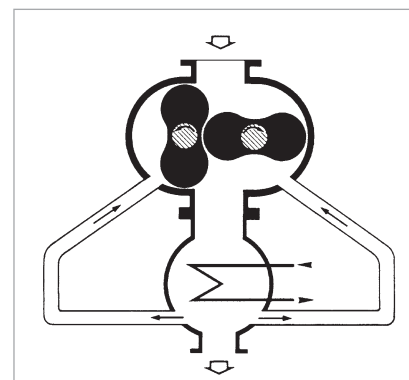

Operating diagram of RUVAC RAV vacuum pumps with pre-admission cooling

TVD Pump Systems for Drying, Evaporation and Distillation Applications

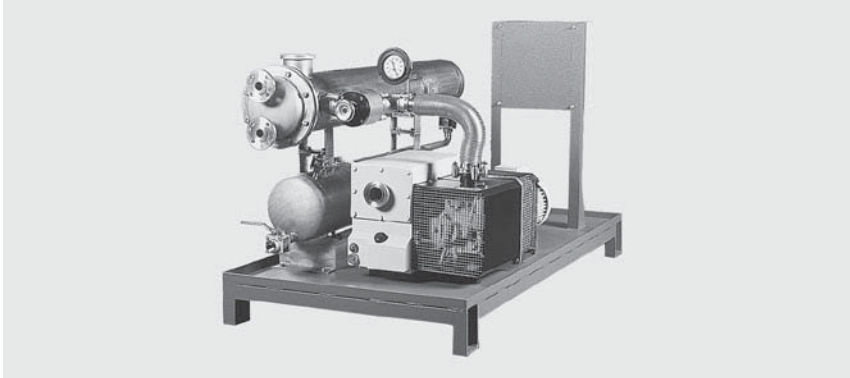

TVD 200

Advantages to the User

- Operating agent may be reused, for example by returning cleaned water to the process
- Reduction of the quantities which need to be disposed of by 80%
- Low temperature distillation/drying
- Condensate may be drained during vacuum operation
- CE approval

Typical Applications

- Drying of powders and solids, for example
- Cleaning of waste water
- Vacuum distillation

Standard Equipment

- Condenser at the intake side
- Receiver with condensate level indicator
- Manually operated valves on the receiver
- SOGEVAC rotary vane vacuum pump with integrated exhaust filters, anti-suckback valve and gas ballast valve

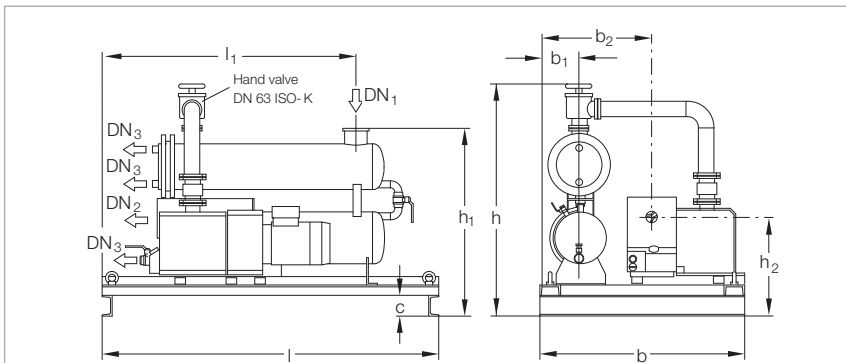

Type	DN ₁	DN ₂	DN ₃	l	l ₁	b	b ₁	b ₂	h	h ₁	h ₂	c
TVD 40 mm	63 ISO-K	1 1/4"	1"	1000	590	700	160	445	1000	785	341	100
in.			1"	39.37	23.23	27.56	6.30	17.52	39.37	30.91	13.43	3.94
TVD 65 mm	63 ISO-K	1 1/4"	1"	1280	755	700	160	445	1165	950	341	100
in.			1"	50.39	29.72	27.56	6.30	17.52	45.87	33.46	13.43	3.94
TVD 100 mm	100 ISO-K	2"	1"	1400	755	940	160	561	1165	950	345	100
in.			1"	55.12	29.72	37.01	6.30	22.09	45.87	33.46	13.58	3.94
TVD 200 mm	100 ISO-K	2"	1"	1800	765	940	150	501	1175	960	473	100
in.			1"	70.87	30.12	37.01	6.30	19.72	46.25	37.80	18.62	3.94

Dimensional drawing for the TVD pump systems

Options

- Valve between condenser and rotary vane vacuum pump
- Pressure gauge for checking the condensate pressure
- Solenoid valves at the receiver
- Receiver with proximity switch for monitoring the condensate level
- Electric control for automatic operation of the pump system
- Mobile pallet with castors
- Cold water replacement for mobile applications

Technical Data, 50 Hz
TVD 40
TVD 65
TVD 100
TVD 200

Condenser, effective surface area, approx.	m ²	1	2	3	5
Receiver, usable volume	l (qt)	30.0 (31.71)	50.0 (52.85)	50.0 (52.85)	50.0 (52.85)
Rotary vane vacuum pump	SOGEVAC	SV 40	SV 65	SV 100	SV 200
Nominal pumping speed	m ³ x h ⁻¹ (cfm)	46.0 (27.1)	65.0 (38.3)	100.0 (58.9)	180.0 (106.0)
Pumping speed at 50 Hz for air	m ³ x h ⁻¹ (cfm)	46.0 (27.1)	53.0 (31.2)	94.0 (55.4)	170.0 (100.1)
for water vapor at 50 mbar (37.5 Torr)	m ³ x h ⁻¹ (cfm)	280.0 (165.0)	560.0 (330.0)	840.0 (495.0)	1400.0 (825.0)
Ultimate total pressure with standard gas ballast	mbar (Torr)	< 1.5 (< 1.1)	< 1.5 (< 1.1)	< 1.5 (< 1.1)	< 0.7 (< 0.53)
Noise level ¹⁾	dB(A)	63	64	70	69
Condensing capacity for water	l x h ⁻¹	10	20	30	50
Installed motor power 400 V, 50 Hz	kW (hp)	1.1 (1.5)	1.5 (2.0)	2.2 (3.0)	4.0 (4.2)

¹⁾ Operating at ultimate pressure with gas ballast

Technical Data, 50 Hz
SV 40
SV 65
SV 100
SV 200

Weight (with oil filling), approx.	kg (lbs)	125 (276)	150 (331)	200 (441)	300 (662)
Oil filling	l (qt)	2.0 (2.11)	2.0 (2.11)	3.5 (3.70)	5.0 (5.29)
Connecting flanges					
Inlet port	DN ₁	63 ISO-K	63 ISO-K	100 ISO-K	100 ISO-K
Outlet port	DN ₂	1 1/4"	1 1/4"	2"	2"

Ordering Information
TVD 40
TVD 65
TVD 100
TVD 200

	Part No.	Part No.	Part No.	Part No.
Pump system	021 01	021 02	021 03	021 04

Accessories for oil sealed and dry compressing Pump Systems

Sound Proofing

A sound proofing box is available as an optional extra so as to reduce the noise down to the permissible level.

Depending on the size of the pumping system, noise reductions between 15 and 20 dB(A) are obtained using our standard sound proofing arrangements.

Custom designs of the sound proofing box allow the noise level to be reduced by up to 35 dB(A).



RUTA RA 3001/S630F/G with sound proofing box

The maintenance side is designed as a door component. A window insert may be provided in the door or in the side walls to facilitate checking of the oil levels.

Ventilation is performed by means of an electric fan, the fresh air and exhaust ducts are located within the sound proofing box. Further optional extras which may be fitted include closed air circulation with integrated, water-cooled heat exchanger and a connection port for a central exhaust system.

Isolation against Vibrations

RUTA vacuum pump systems produce only slight vibrations. To reduce these vibrations even further, vibration absorbers can be fitted under the pump system.

Dust Separators

Vacuum processes where large amounts of particles or dusts are contributed by the process require special devices to protect the vacuum pumps.

Oerlikon Leybold Vacuum has developed – even for high flow rate applications – special dust separators, which can be installed ahead of the intake of the RUTA vacuum pump systems. The dust separators have two stages. The first stage is a cyclone that collects dust particles of coarse and medium size, the fine dust are trapped in filter elements. Dust separators are custom-designed for the specific process and the required pumping speed.

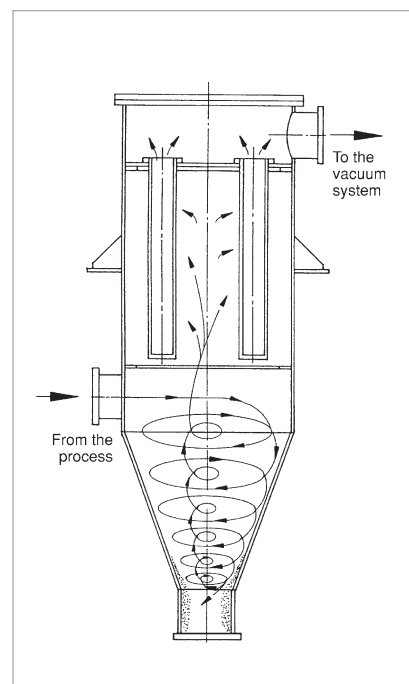

Diagrammatic section through a dust separator

Dust Filter without Cyclone

See further down in this chapter.

Filtering surface suitable for pumping speeds	m ²	0.2	0.5	1.0	2.0	3.0	5.0
min.	m ³ x h ⁻¹ (cfm)	100 (58.9)	300 (176.7)	600 (353.4)	1000 (589)	1500 (883.5)	3000 (1767)
max.	m ³ x h ⁻¹ (cfm)	300 (176.7)	800 (471.2)	1500 (883.5)	3000 (1767)	4000 (2356)	8000 (4712)
Reduction of pumping speed at							
≤ 1 mbar (< 0.75 Torr)	%	11	11	11	11	11	11
≤ 6 mbar (< 4.5 Torr)	%	9	9	9	9	9	9
≤ 20 mbar (< 15 Torr)	%	5	5	5	5	5	5

without dust load

Frequency converter RUVATRONIC RT 5

The electronic frequency inverters RUVATRONIC RT 5/251 to 5/16000 have been designed specially for use in connection with Oerlikon Leybold Vacuum Roots pumps of the RUVAC type.

For each Roots vacuum pump size, a matching frequency converter is available.

The main characteristics of the RUVATRONIC RT 5 are:

Simulation of a pressure equalization line

The software of the frequency inverters is adapted to each pump and ensures that the risk of mechanically overloading the pump can be excluded. In the case of too high pressure differences, the rotational speed will be decreased

automatically until the load is reduced to within the pump's limits.

RUVAC Roots vacuum pumps of the types WA, WS and RA (without pressure equalization line) can be switched on together with the forepump at atmospheric pressure. Through this, the pumpdown time can be reduced drastically.

The minimum pumping speed of the backing pump needs to be considered in this case.

Pump	Required pumping speed for the backing pump
WA/WS 251	50 m ³ /h (29 cfm)
WA/WS 501	100 m ³ /h (59 cfm)
WA/WS 1001	200 m ³ /h (118 cfm)
WA/WS 2001	410 m ³ /h (241 cfm)
RA 3001	650 m ³ /h (383 cfm)
RA 5001	930 m ³ /h (547 cfm)
RA 7001	1250 m ³ /h (736 cfm)
RA 9001	3240 m ³ /h (1907 cfm)

Operation at up to 3 predefined speeds

Via floating contacts, the pump can be operated at one of the 3 predefined speeds. Switching over to another pre-defined speed is possible during operation.

Operation at any rotational speed

With a 0 to 10 V signal, any speed can be pre-defined to operate the pump between the minimum and maximum rotational speed. The software reliably ensures that the rotational speed cannot drop below the minimum speed or exceed the maximum speed.

Increase in the pumping speed

By operating the Roots vacuum pumps at frequencies over 50 Hz, the nominal pumping speed of the pumps can be increased. Depending on the type of pump, an increase between 20 and 100% is possible.

Note

Please enquire about possible application limitations (process dependent).

Electric Controller

In order to drive all electrical appliances within the pump systems, the pump systems may be equipped with standard control cabinets which contain:

- Motor protection switch (rated for the pumps used in each case)
- Contactors
- Main switch interlocked in accordance with VDE 0113
- Relays for necessary control/sub-systems
- ON/OFF push-button for each pump
- Power supply for the installed monitoring facilities
- Fault indicators arranged on a lamp panel
- Switch-over (through an external contact) from local to remote operation.

The control cabinet may be fitted either to the frame of the pump system or it may be wallmounted.

Beside the standard systems, we manufacture control systems for much more complex systems:

- Remote control module as a 19" rack module (1/4 width, 3 HU). The start/stop push-buttons and the related indicators for operation and fault are located on the front panel
- Pre- and post-operation control
- Pressure dependant control
- Time-dependant control
- Program control
- Control for explosion hazard areas
- Combinations of the aforementioned versions
- Programmable control (PC)
- Vacuum gauge with pressure read-out in the control cabinet.

Pressure Control

Basically there are several ways in which to control the pressure.

The equipment which is supplied as standard for the **DOWNSTREAM** or **BYPASS** control systems selected by Oerlikon Leybold Vacuum consists of:

- Pressure measurement
- Controller with control unit
- Control valve with position indicator
- Engineering.

The Downstream Control System

throttles the pumping speed of the vacuum pump by changing the conductance of the valve.

The advantages offered by this arrangement are:

- No supply of other gases
- Closed system
- The intake pressure of the pump system is lower than its operating pressure (thus saving energy, among other things).

The second method is the **Bypass Control System**. Here the pressure is maintained at a constant level by admitting an additional quantity of gas.

The advantages offered by this arrangement are:

- Simple design
- Much smaller valve
- No reduction of the intermediate pressure within the pump.

In order to design a pressure control system we need the following information:

- Amount of gas
- Type of gas
- Pressure
- Length of the piping
- Type of auxiliary energy (electric/pneumatic)
- Explosion protection required yes/no.

Additional complex control arrangements are available, for example with:

- Adjustable pressure characteristic
- Adjustable timing
- Speed control
- Combination with other control facilities.

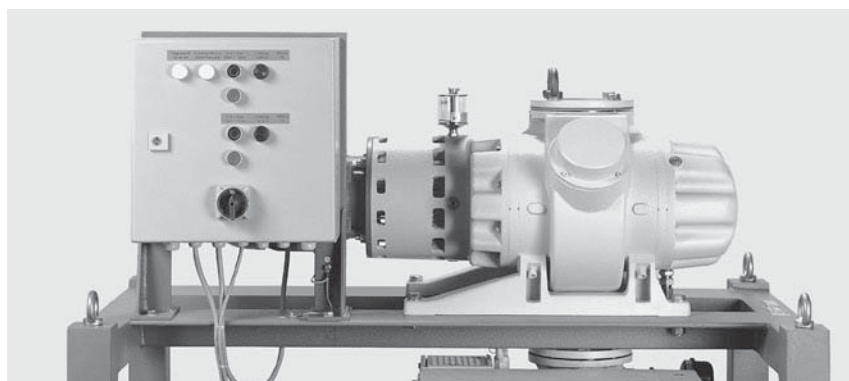

Control panel on RUTA WAU1001/SV200/G

Dust Filter F-xxx-C

The highly efficient dust filters F-xxx-C are fitted to the inlet of the RUVAC pumps. The filter protects the Roots vacuum pumps against the intake of dust.

The dust filters are equipped with an easy to replace filter element. In the case of the filters F-1001-C or larger, the gas enters into the housing above the filter element. Thus the likelihood of puncturing the filter is reduced.

In the case of the dust filter F-501-C, the filter element is protected by a baffle.

All vacuum dust filters are rated for pressures up to 1200 mbar (900 Torr) abs. max.

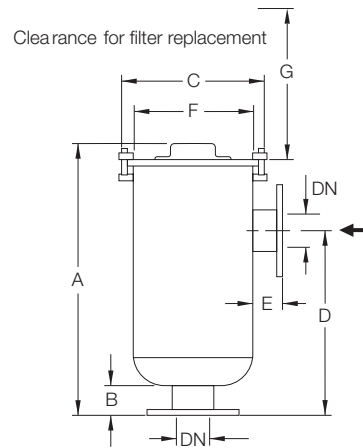

Type		DN	A	B	∅ C	D	E	F	G
F-501-C	mm	65 ¹⁾	312	76	222	185	76	195	235
	in.		12.28	2.99	8.74	7.28	2.99	7.68	9.25
F-1001-C	mm	100 ¹⁾	692	76	356	470	74	310	381
	in.		27.24	2.99	14.02	18.50	2.91	12.20	15.00
F-2001-C	mm	150 ¹⁾	740	102	470	521	102	406	254
	in.		29.13	4.02	18.50	20.51	4.02	15.98	10.00
F-2001-C plus	mm	150 ¹⁾	740	102	470	521	99	413	508
	in.		29.13	4.02	18.50	20.51	3.90	16.26	20.00
F-5001-C	mm	200 ²⁾	1031	102	572	648	103	505	508
	in.		40.59	4.02	22.52	25.51	4.02	19.88	20.00
F-7001-C	mm	250 ²⁾	1454	102	686	1143	99	616	838
	in.		57.24	4.02	27.01	45.00	3.90	24.33	32.99
F-9001-C	mm	300 ²⁾	1454	102	686	1143	99	616	838
	in.		57.24	4.02	27.01	45.00	3.90	24.33	32.99
F-13001-C	mm	300 ²⁾	1784	102	686	1448	99	616	635
	in.		70.24	4.02	27.01	57.01	3.90	24.33	25.00

¹⁾ The hole pattern corresponds to PN 6 and may be connected by using collar flanges to ISO-K components

²⁾ The hole pattern corresponds to PN 10

Dimensional drawing for the dust filters F-xxx-C

Technical Data

Dust Filter F-xxx-C

		Polyester filter cartridge	Paper filter cartridge
Separation at 10 µm	%	> 99.9	–
Separation at 5 µm	%	> 99	> 99.9
Separation at 2 µm	%	–	> 99
Temperature	°C (°F)	-25 to +100 (-13 to +212)	-25 to +100 (-13 to +212)
Dust filter for WA/WS/WAU/WSU 501 WA/WS/WAU/WSU 1001, WH 700 WA/WS/WAU/WSU 2001, WH 2500 RA 3001, RA 5001, WH 4400, WH 7000 RA 7001 RA 9001 RA 13000		F-501-C F-1001-C F-2001-C / F-2001-C plus F-5001-C F-7001-C F-9001-C F-13001-C	F-501-C F-1001-C F-2001-C / F-2001-C plus F-5001-C F-7001-C F-9001-C F-13001-C

Technical Data

Dust Filter

		F-501-C	F-1001-C	F-2001-C	F-2001-C plus
Surface area, approx.					
Polyester	m ²	0.4	1.0	1.5	2.6
Paper	m ²	1.3	3.0	4.0	6.3
Weight, approx.	kg (lbs)	7.0 (15.45)	29.0 (64.02)	50.0 (110.38)	51.0 (112.58)

Technical Data

Dust Filter

		F-5001-C	F-7001-C	F-9001-C	F-13001-C
Surface area, approx.					
Polyester	m ²	4.5	9.0	9.0	14.0
Paper	m ²	11.5	26.0	26.0	37.0
Weight, approx.	kg (lbs)	83.0 (138.22)	171.0 (377.48)	171.0 (377.48)	209.0 (461.37)

Ordering Information

Dust Filter F-xxx-C

	Part No.	Part No.
Dust Filter	Polyester filter element	Paper filter element
F-501-C	500 001 403	500 001 404
Replacement filter element FE-501-C	500 005 629	500 005 630
F-1001-C	500 000 301	500 000 302
Replacement filter element FE-1001-C	500 000 313	500 000 314
F-2001-C	500 000 303	500 000 304
Replacement filter element FE-2001-C	500 000 315	500 000 316
F-2001-C plus ¹⁾	500 001 367	500 001 368
Replacement filter element FE-2001-C plus	500 005 631	500 005 632
F-5001-C	500 000 305	500 000 306
Replacement filter element FE-5001-C	500 000 317	500 000 318
F-7001-C	500 000 307	500 000 308
Replacement filter element FE-7001/9001-C	500 000 319	500 000 320
		(2 pieces are required)
F-9001-C	500 000 309	500 000 310
Replacement filter element FE-7001/9001-C	500 000 319	500 000 320
		(2 pieces are required)
F-13001-C	500 000 311	500 000 312
Replacement filter element FE-13001-C	500 000 321	500 000 322
	(2 pieces are required)	(2 pieces are required)

¹⁾ For increased quantities of dust

Bellows with Vibration Absorbers



Bellows with vibration absorbers

The bellows serve the purpose of connecting pipes to vacuum pumps without introducing any mechanical tensions.

Technical Data

Bellows with Vibration Absorbers

KIT DN 63 ISO-K KIT DN 100 ISO-K KIT DN 160 ISO-K

		KIT DN 63 ISO-K	KIT DN 100 ISO-K	KIT DN 160 ISO-K
Length	mm (in.)	132 (5.20)	132 (5.20)	150 (5.91)
Lateral movement, max.	mm (in.)	7.5 (0.30)	9.5 (0.37)	3.5 (0.14)
Axial movement, max.	mm (in.)	20 (0.79)	28 (1.10)	22 (0.87)

Ordering Information

Bellows with Vibration Absorbers

KIT DN 63 ISO-K KIT DN 100 ISO-K KIT DN 160 ISO-K

		Part No.	Part No.	Part No.
Bellows with vibration absorbers		503 189 V001	503 189 V002	503 189 V003
consisting of				
Bellows	Quantity	1	1	1
Centering ring	Quantity	2	2	2
Clamp (set of 4 pieces)	Quantity	2	2	2
Support bracket	Quantity	4	8	8
Rubber/metal absorber	Quantity	2	4	4
Hexagon nut M 12	Quantity	12	24	24
Threaded rod M 12				
105 mm long	Quantity	4	8	8
Washer	Quantity	12	24	24

Technical Data

Bellows with Vibration Absorbers

KIT DN 200 ISO-K KIT DN 250 ISO-K KIT DN 320 ISO-K

		KIT DN 200 ISO-K	KIT DN 250 ISO-K	KIT DN 320 ISO-K
Length	mm (in.)	150 (5.91)	200 (7.87)	250 (9.84)
Lateral movement, max.	mm (in.)	3.5 (0.14)	4.5 (0.18)	4.5 (0.18)
Axial movement, max.	mm (in.)	20 (0.79)	30	50

Ordering Information

Bellows with Vibration Absorbers

KIT DN 200 ISO-K KIT DN 250 ISO-K KIT DN 320 ISO-K

		Part No.	Part No.	Part No.
Bellows with vibration absorbers		503 189 V004	503 189 V005	503 189 V006
consisting of				
Bellows	Quantity	1	1	1
Centering ring	Quantity	2	2	2
Clamp (set of 4 pieces)	Quantity	3	3	4
Support bracket	Quantity	12	12	16
Rubber/metal absorber	Quantity	6	6	8
Hexagon nut M 12	Quantity	36	36	48
Threaded rod M 12				
90 mm long	Quantity	12	12	–
105 mm long	Quantity	–	–	16
Washer	Quantity	36	36	48

Bus Interfaces for Monitoring

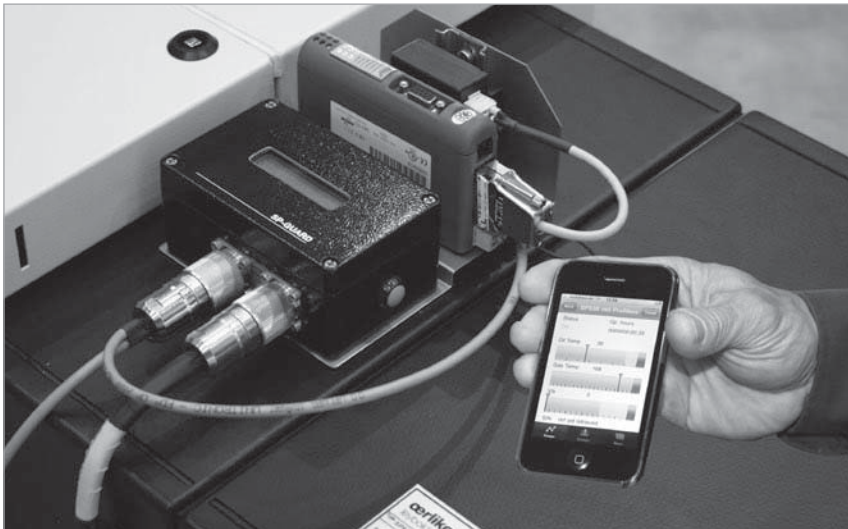

Wi-Fi and Profibus interface kit for SP-GUARD

Bus interfaces for remote reading of the SP-GUARD monitoring system for the screw pumps SCREWLINE SP 250 and SP 630. Item can be ordered as retrofit kit or together with the pump unit.

Advantages to the User

- Interface box for assembly on screw pump SCREWLINE SP 250 and SP 630
- Read out of vibration levels, oil temperatures, warning and failure functions
- The interface box is mounted next to the SP-GUARD
- Interface box needs a 24 V DC supply on-site (24 V DC supply of the SP-GUARD can be used)

Available Interfaces

- Profibus
- Wi-Fi

Further interfaces upon request:

- Profinet
- DeviceNet
- Ethernet
- CAN bus
- Interbus
- etc.

Ordering Information

Interface Kit SP-GUARD

	Part No.
Interface kit SP-GUARD Profibus	502 898 V001
Profibus kit and Wi-Fi with iPhone for SP-GUARD	503 264 V901
Profibus interface kit and Wi-Fi for SP-GUARD	503 183 V901
SCREWLINE SP 630 screw pump with Profibus interface	502 899 V001
Further combinations	upon request

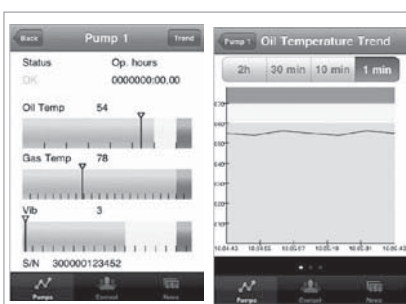

Various indications on the mobile equipment



Profibus interface kit for SP-GUARD



Smart phone / tablet PC for readout (Wi-Fi)

Miscellaneous to oil sealed and dry compressing Pump Systems

Checklist for Inquiries

To Oerlikon Leybold Vacuum GmbH From company: _____
Dept. Systems Name/Department: _____
Fax: +49 (0)221/347 - 31206 Phone: _____ Date: _____
e-Mail: vacuum.solutions@oerlikon.com Fax: _____ First page of: _____

MAKE USE OF OUR KNOW-HOW !

Simply fax the completed checklist to us. Our engineers will design a pump system which exactly matches your requirements. You will receive an offer shortly.

1. In what kind of application will the pump system be used (e.g. drying, distillation)?

2. Is the process run
 continuously in batches:

3. What is the volume of the vacuum chamber?

_____ m³

4. What pump-down times are required/desired?

_____ min³ x h⁻¹

5. What operating pressures are planned?

_____ mbar

6. How high is the ambient temperature?

- when installed in the building:
min. _____ °C / max. _____ °C

- when installed out in the open
min. _____ °C / max. _____ °C

7. How high is the intake temperature?

_____ °C

8. What is the composition of the gas which is to be pumped.

Designation:
a) _____ b) _____
c) _____ d) _____
e) _____ f) _____

9. Quantity (kg/h or Nm³/h), traces (%):

a) _____ b) _____
c) _____ d) _____
e) _____ f) _____

10. In case of materials not commonly listed in the tables please state:

a) Molecular mass _____
b) Thermal capacity _____
c) Vapor pressure _____

d) Viscosity _____

e) Melting point _____

f) Special characteristics _____

11. Must explosion hazard regulations be observed?

yes no

if yes, which? _____

12. What kind of electrical supplies are available?

a) Voltage _____

b) Frequency _____

13. What kind of mechanical connection specifications are planned?

a) Length of the intake line _____

b) Diameter of the intake line _____

14. Which cooling media are available (water, brine, etc.)? Which temperature?

_____ min. _____ °C

_____ max. _____ °C

General to High Vacuum Pump Systems TMP

The requirements of production or research engineers concerning the vacuum technology they have to employ are usually widely different. In most cases pumping speed and operating pressure must be accurately matched to suit a particular process. The wide range of vacuum pumps and standard accessories available offers many options.

Sometimes it is just this flexibility which causes difficulties when having to decide between the various configurations of a particular pump system. Based on our experience and by listening to our customers' demands, we have therefore compiled a range of turn-key vacuum systems based on standard components.

Before leaving the factory they are subjected to both functional tests and leak tests. By adding components from our standard range or special accessories they may be easily adapted to meet specific requirements.

Application and Accessories

Pump systems	PT 50	PT 151 / PT 361	PT 50 KIT	PT 151 KIT	PT 361 KIT	PT 80 DRY	PT 80 H DRY	TURBOLAB 80	PT 151 DRY	PT 361 DRY	PT 300 DRY	PT-Flex
Application												
Microbalances	■	■	■	■	■	■	■	■	■	■	■	■
Sputtering	■	■	■	■	■	■	■	■	■	■	■	■
Spectroscopy	■	■	■	■	■	■	■	■	■	■	■	■
Production of TV and monitor picture tubes	■	■	■	■	■	■	■	■	■	■	■	■
Surface refining	■	■	■	■	■	■	■	■	■	■	■	■
Evaporation coating systems	■	■	■	■	■	■	■	■	■	■	■	■
Beam guidance systems	■	■	■	■	■	■	■	■	■	■	■	■
Laboratory pump systems	■	■	■	■	■	■	■	■	■	■	■	■
Accessories												
Control unit for turbomolecular pump systems	■	■				■	■		■	■	■	■
Air cooling unit	■	■	■	■	■	▲	▲	▲	■	■	▲	■
Flange heater	■	■	■	■	■	■			■	■	■	■
Venting valve	■	■	■	■	■	■	■	■	■	■	■	■
Power failure venting valve	■	■	■	■	■	■	■	■	■	■	■	■
Purge gas and venting valve		■		■	■	■			■	■	■	■
Adsorption traps with aluminium oxide insert	■	■	■	■	■							
Exhaust filter	■	■	■	■	■							
Water cooling unit	■	▲	■	▲	▲	■	■		▲	▲	■	■

■ Possible
▲ Included in standard scope of delivery

Vacuum Pump
Systems

Products

Oil Sealed Pump Systems PT 50 Turbomolecular Pump System



Example: PT 50 with options
(switch box, gauge)

The turbomolecular pump system PT 50 is a fully assembled and ready-to-operate high vacuum pump system benchtop unit for producing a high and ultra-high vacuum.

Advantages to the User

- Low ultimate pressure ($< 10^{-8}$ mbar ($< 0.75 \times 10^{-8}$ Torr))
- High pumping speed of the backing pump
- High effective pumping speed
- Compact, small, rugged unit
- Simple to operate
- High level of reliability
- Maintenance-friendly design
- Air cooling
- For use worldwide
- Installation of standard vacuum components in an open frame
- Rugged table top unit which may also carry heavy assemblies
- Service friendly assembly for maintenance without the need to disassemble backing or high vacuum pump
- The high vacuum pump can be removed from the pump system (any installation orientation)
- CE approval

The turbomolecular pump system consists of the following principal components:

- Grease lubricated turbomolecular pump TURBOVAC 50 with ceramic ball bearings, convection cooling and splinter guard
- Electronic frequency converter NT 10
- Dual-stage, oil sealed rotary vane vacuum pump TRIVAC D 2,5 E as backing pump
- All required connecting and sealing components are located within the pump system assembly

- Either with or without switchbox

- With switchbox

The pumps are switched on and off via a rotary switch on the front. Power sockets for accessories (one measuring instrument and one power failure venting valve) are provided. These are connected by means of a power cord with Schuko plug. Other connection lines can be specified also for retrofitting (see Ordering Information)

- Without switchbox

The pumps are switched on and off via switches at the pump, respectively at the frequency converter. For each component a separate earthed mains power outlet is required.

The pump system can be upgraded with further components, for example:

- Switchbox
- Vacuum gauge
- Power failure venting valve
- Air cooling unit
- Adsorption trap
- Exhaust filter
- Rotatable castors
- Venting valve
- Assembly on the intake side with manifold, valves, gauge heads etc.

Typical Applications

- Spectroscopy
- Tube manufacturing
- Beam guidance systems
- Micro balances
- Sputtering and evaporation systems
- Surface physics
- Laboratory pump systems
- Production of gas Lasers

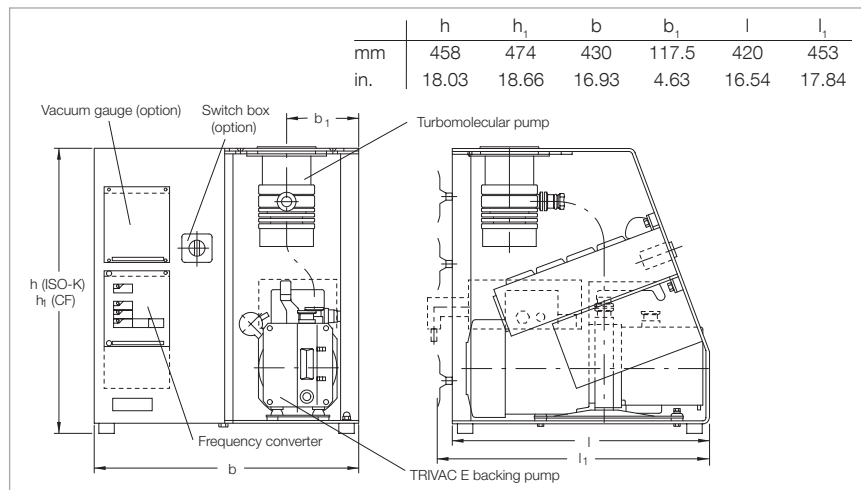

Dimensional drawing for the PT 50 turbomolecular pump system

Technical Data

PT 50

Turbomolecular pump		TURBOVAC 50	TURBOVAC 50	TURBOVAC 50
High vacuum connection	DN	40 ISO-KF	63 ISO-K	63 CF
Pumping speed for N ₂	l x s ⁻¹	33	55	55
Compression for N ₂ / H ₂		2 x 10 ⁷ / 10 ²	2 x 10 ⁷ / 10 ²	2 x 10 ⁷ / 10 ²
Speed of the TURBOVAC	rpm	72 000	72 000	72 000
Dual-stage rotary vane vacuum pump		TRIVAC D 2,5 E	TRIVAC D 2,5 E	TRIVAC D 2,5 E
Nominal pumping speed acc. to PNEUROP	m ³ x h ⁻¹ (cfm)	2.7 (1.6)	2.7 (1.6)	2.7 (1.6)
Ultimate total pressure	mbar (Torr)	10 ⁻³ (0.75 x 10 ⁻³)	10 ⁻³ (0.75 x 10 ⁻³)	10 ⁻³ (0.75 x 10 ⁻³)
Attainable ultimate pressure with FPM (FKM) gasket	mbar (Torr)	10 ⁻⁷ (0.75 x 10 ⁻⁷)	10 ⁻⁷ (0.75 x 10 ⁻⁷)	10 ⁻⁷ (0.75 x 10 ⁻⁷)
CF version with aluminum or Cu gasket	mbar (Torr)	-	-	10 ⁻⁸ (0.75 x 10 ⁻⁸)
Main supply, 50/60 Hz	V	200-240 ¹⁾	200-240 ¹⁾	200-240 ¹⁾
Power consumption, max.	VA	315	315	315
Dimensions (W x H x D)	mm (in.)	see dimensional drawing	see dimensional drawing	see dimensional drawing
Weight, approx.	kg (lbs)	27 (59.4)	27 (59.4)	27 (59.4)

Ordering Information

PT 50

	Part No.	Part No.	Part No.
PT 50 turbomolecular pump system, 230 V, 50 Hz ¹⁾			
without switchbox, connection via 2 Schuko plugs			
DN 40 ISO-KF	503265V001	-	-
DN 63 ISO-K	-	503266V001	-
DN 63 CF	-	-	503267V001
with switchbox and mains cord with 1 Schuko plug			
DN 40 ISO-KF	503265V002	-	-
DN 63 ISO-K	-	503266V002	-
DN 63 CF	-	-	503267V002
Accessories			
Air cooling unit			
100 V	800152V0015	800152V0015	800152V0015
115 V	854 06	854 06	854 06
230 V	854 05	854 05	854 05
Water cooling unit (10 mm dia. hose nozzle)	800135V003	800135V003	800135V003
Flange heater			
DN 63 CF, 115 V	-	-	854 07
DN 63 CF, 230 V	-	-	854 04
Venting valve, DN 10 ISO-KF manually operated	173 24	173 24	173 24
Power failure venting valve, DN 10 ISO-KF 230 V, 50/60 Hz	174 26 ²⁾	174 26 ²⁾	174 26 ²⁾
Adsorption trap, DN 16 ISO-KF Adsorbent 1.6 l	854 14 ³⁾ 854 10	854 14 ³⁾ 854 10	854 14 ³⁾ 854 10
Exhaust filter AF 8	190 50	190 50	190 50
Mains cord for PT with switchbox			
US/Japan 230 V, 50/60 Hz	200 81 141	200 81 141	200 81 141
CH 230 V, 50/60 Hz	200 81 099	200 81 099	200 81 099
UK 230 V, 50/60 Hz	200 81 097	200 81 097	200 81 097
Connecting cable for operating the TURBOVAC outside the pump system			
3 m (7.0 ft)	121 08	121 08	121 08
5 m (17.5 ft)	121 09	121 09	121 09
10 m (35.0 ft)	161 10	161 10	161 10
20 m (70.0 ft)	800150V2000	800150V2000	800150V2000
Rotatable castors PT 50/80	503227V901	503227V901	503227V901

¹⁾ Other voltages upon request

²⁾ Deliveries in the case of reorders are without connection cable

³⁾ Delivery without adsorbent, please order separately

PT 151/PT 361 Turbomolecular Pump Systems



Example: PT 151 with switch box

These turbomolecular pump systems are ready-to-operate vacuum units for generating a vacuum in the high and ultra-high vacuum range.

When pumping aggressive or abrasive process gases, a purge gas facility must be used for the pumps.

Advantages to the User

- Low ultimate pressure ($< 10^{-10}$ mbar/Torr)
- High backing pump pumping speed
- High effective pumping speed
- Compact, mobile unit
- Simple to operate
- High level of reliability
- Venting port
- Purge gas port (only at C version)
- Service friendly assembly for maintenance without the need to disassemble backing or high vacuum pump
- Pump systems prepared for installation of larger backing pumps (for barrier gas operation, for example)
- CE approval

The turbomolecular pump systems consists of the following principal components:

- Grease lubricated turbomolecular pump TURBOVAC 151 or 361 with splinter guard
- Electronic frequency converter TD 20^{classic}
- Dual-stage, oil sealed TRIVAC D 4 B or D 16 B rotary vane vacuum pump as backing pump (further sizes upon request)
- All necessary connection and sealing components within the pump system

Typical Applications

- **Either with or without switchbox**
 - *With switchbox*

The pumps are switched on and off via a rotary switch on the front. Power sockets for accessories (Gauge, power failure venting valve, air cooler and flange heater) are provided. These are connected by means of a power cord with Schuko plug. Other connection lines can be specified also for retrofitting (see Ordering Information)
 - *Without switchbox*

The pumps are switched on and off via switches at the pump, respectively at the frequency converter. For each component a separate earthed mains power outlet is required.
- Spectroscopy
- Tube manufacturing
- Beam guidance systems
- Microbalances
- Sputtering and evaporation systems
- Surface physics

Further components can be added to the pump systems, for example:

- Switch box
- Vacuum gauges (up to two)
- Adsorption trap
- Exhaust filter
- Air cooling unit
- Flange heater
- Power failure venting valve
- Venting valve
- Purge gas valve (only at C version)
- Intake arrangement with manifold, valves and vacuum gauges etc.

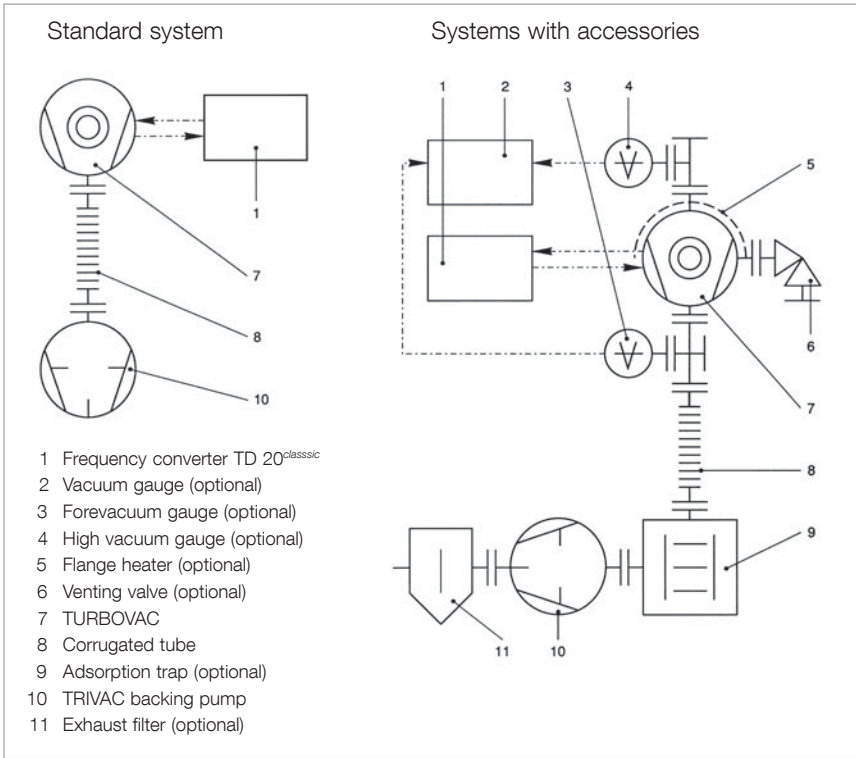

Vacuum diagram of the PT 151/PT 361 turbomolecular pump systems with rotary vane vacuum pump TRIVAC

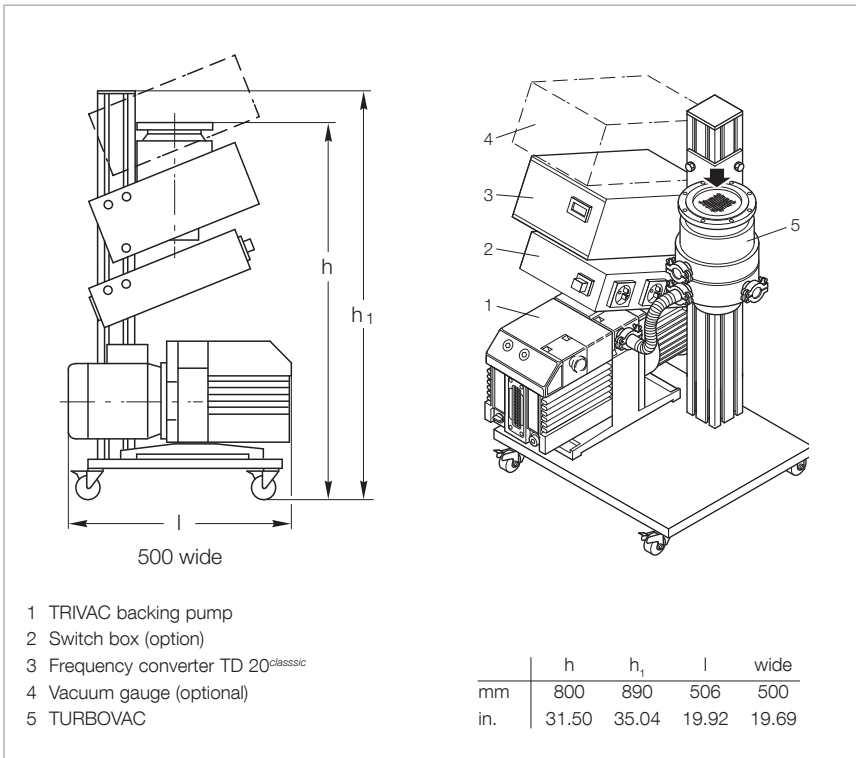

PT 151/PT 361 turbomolecular pump system with rotary vane vacuum pump TRIVAC

Technical Data
PT 151
PT 361

Turbomolecular pump		TURBOVAC 151	TURBOVAC 151	TURBOVAC 361	TURBOVAC 361
High vacuum connection	DN	100 ISO-K	100 CF	100 ISO-K	100 CF
Pumping speed for N ₂	l x s ⁻¹	145	145	345	345
Compression for N ₂ /H ₂		1 x 10 ⁹ / 8 x 10 ²	1 x 10 ⁹ / 8 x 10 ²	1 x 10 ⁹ / 3 x 10 ³	1 x 10 ⁹ / 3 x 10 ³
Speed of the TURBOVAC	rpm	50 000	50 000	50 000	50 000
Dual-stage rotary vane vacuum pump		TRIVAC D 4 B	TRIVAC D 4 B	TRIVAC D 16 B	TRIVAC D 16 B
Nominal pumping speed (DIN 28 400)	m ³ x h ⁻¹ (cfm)	4.8 (2.83)	4.8 (2.83)	18.9 (11.13)	18.9 (11.13)
Exhaust connection	DN	16 ISO-KF	16 ISO-KF	25 ISO-KF	25 ISO-KF
Attainable ultimate pressure					
with FPM (FKM) gasket	mbar (Torr)	10 ⁻⁸ (0.75 x 10 ⁻⁹)	10 ⁻⁸ (0.75 x 10 ⁻⁹)	10 ⁻⁸ (0.75 x 10 ⁻⁹)	10 ⁻⁸ (0.75 x 10 ⁻⁹)
with Cu seal	mbar (Torr)	–	10 ⁻¹⁰ (0.75 x 10 ⁻¹⁰)	–	10 ⁻¹⁰ (0.75 x 10 ⁻¹⁰)
Cooling water consumption	l/h	15-35	15-35	15-35	15-35
Cooling water connection, hose nozzle	mm (in.)	10 (0.39)	10 (0.39)	10 (0.39)	10 (0.39)
Power consumption, max.	VA	770	770	1150	1150
Mains supply 50/60 Hz	V	210-230 ¹⁾	210-230 ¹⁾	218-240 ¹⁾	218-240 ¹⁾
Dimensions (W x H x D)	mm (in.)	see dimensional drawing	see dimensional drawing	see dimensional drawing	see dimensional drawing
Weight, approx.	kg (lbs)	45 (99.2)	45 (99.2)	62 (136.7)	62 (136.7)

¹⁾ Other voltages upon request

Ordering Information

PT 151

PT 361

	Part No.	Part No.	Part No.	Part No.
Turbomolecular pump system 230 V / 50 Hz ¹⁾ , without switch box, Connection via 2 Schuko plugs with TRIVAC D 4 B with TRIVAC D 16 B	100 ISO-K	100 CF	100 ISO-K	100 CF
	503268V001	503269V001	-	-
	-	-	503270V001	503271V001
230 V, 50 Hz ¹⁾ , with switch box and mains cord with 1 Schuko plug with TRIVAC D 4 B with TRIVAC D 16 B	503268V002	503269V002	-	-
	-	-	503270V002	503271V002
Accessories				
Air cooling unit 100 V 115 V 230 V	800152V0016	800152V0016	800152V0016	800152V0016
	894 08	894 08	894 08	894 08
	855 31	855 31	855 31	855 31
Flange heater, DN 100 CF 115 V 230 V	-	854 28	-	854 28
	-	854 27	-	854 27
Venting valve, DN 10 ISO-KF manually operated	173 24	173 24	173 24	173 24
Power failure venting valve normally open 24 V DC, DN 16 ISO-KF 230 V, 50/60 Hz, DN 10 ISO-KF	800120V0021 ²⁾	800120V0021 ²⁾	800120V0021 ²⁾	800120V0021 ²⁾
	174 26 ²⁾	174 26 ²⁾	174 26 ²⁾	174 26 ²⁾
Purge gas and venting valve, 100-230 V 0.4 mbar x l x s ⁻¹	800152V0014 ²⁾	800152V0014 ²⁾	800152V0014 ²⁾	800152V0014 ²⁾
Filter adapter for gas connection G 1/4"	800110V0012	800110V0012	800110V0012	800110V0012
Replacement filter	200 18 515	200 18 515	200 18 515	200 18 515
Adsorption trap DN 16 ISO-KF DN 25 ISO-KF	854 14 ³⁾	854 14 ³⁾	-	-
	-	-	854 15 ³⁾	854 15 ³⁾
Adsorbent 1.6 l	854 10	854 10	854 10	854 10
Exhaust filter AF 4-8 AF 16-25	189 06	189 06	-	-
	-	-	189 11	189 11
Mains cord for PT with switch box EURO 230 V, 50 Hz CH 230 V, 50/60 Hz UK 230 V, 50/60 Hz US/Japan 230 V, 50/60 Hz	200 81 091	200 81 091	200 81 091	200 81 091
	200 81 099	200 81 099	200 81 099	200 81 099
	200 81 097	200 81 097	200 81 097	200 81 097
	200 81 141	200 81 141	200 81 141	200 81 141
Control unit for turbomolecular pump systems (see Chapter "Accessories")	upon request	upon request	upon request	upon request

¹⁾ Other voltages upon request

²⁾ Deliveries in the case of reorders are without connection cable, purge gas only at C-versions

³⁾ Delivery without adsorbent, please order separately

Turbomolecular Pump Systems

PT 50 KIT, PT 151 KIT, PT 361 KIT

Under the motto “Do-it-yourself and save money” you may assemble the turbomolecular pump systems PT 50 KIT, PT 151 KIT and PT 361 KIT yourself.

The turbomolecular pump systems PT 50 KIT, PT 151 KIT and PT 361 KIT are made of the same components as used for the turn-key systems:

- Base panel with column
- Turbomolecular pump TURBOVAC 50 (PT 50 KIT) or 151 or 361 (PT 151 KIT or PT 361 KIT)
- Rotary vane vacuum pump TRIVAC D 2,5 E (PT 50 KIT) or D 4 B or D 16 B (PT 151 KIT or PT 361 KIT)
- TURBOTRONIK NT 10 electronic frequency converter (PT 50 KIT) or NT 20 (PT 151 KIT and PT 361 KIT)
- All necessary mounting parts, connection parts and gaskets are supplied
- Switch box
- Simple and accurate assembly instructions
- Detailed exploded view
- Description which is easy to understand
- Additional detailed knowledge is gained about the product by assembling it yourself
- CE approval

The technical data, the areas of application and the design characteristics correspond to the turbomolecular pump systems PT 50, PT 151 and PT 361 described on the preceding pages.

Typical Applications

- Spectroscopy
- Tube manufacturing
- Beam guidance systems
- Microbalances
- Sputtering and evaporation systems
- Surface physics
- Laboratory pump systems
- Production of gas lasers

PT 50 KIT



Unpacking, 15 minutes, approx.



After further 20 minutes



After further 20 minutes



After further 30 minutes

PT 151 KIT/PT 361 KIT

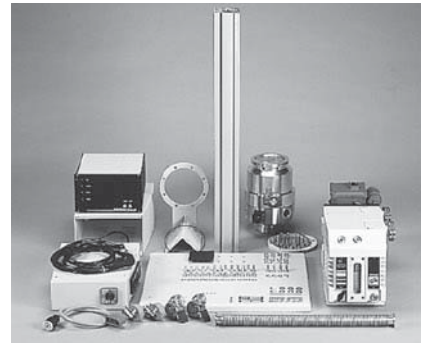

Unpacking, 15 minutes, approx.

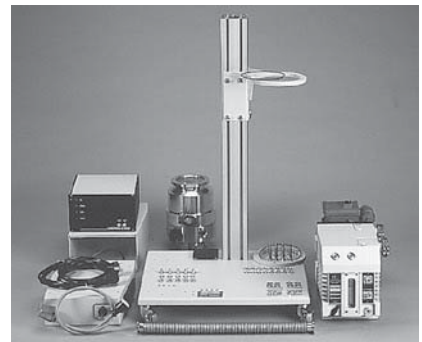

After further 30 minutes

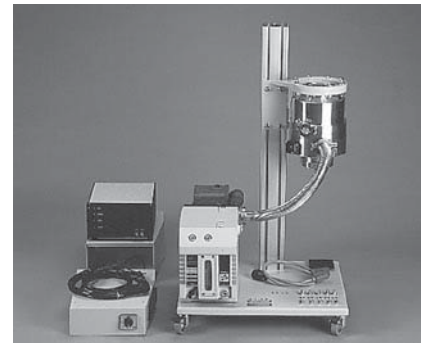

After further 30 minutes

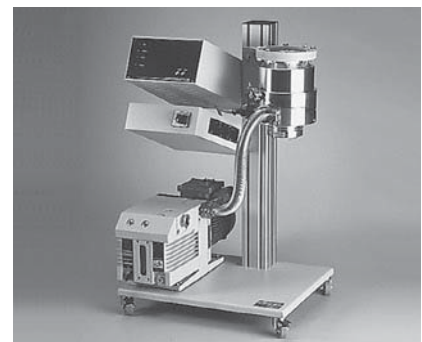

After further 50 minutes

Ordering Information

PT 50 KIT

PT 151 KIT

PT 361 KIT

	Part No.	Part No.	Part No.
PT 50 KIT turbomolecular pump system Air convection cooling 200-240 V, 50/60 Hz DN 40 ISO-KF DN 63 ISO-K DN 63 CF	128 70 128 71 128 73	- - -	- - -
PT 151 KIT turbomolecular pump system, water-cooled 210-230 V, 50/60 Hz DN 100 ISO-K DN 100 CF	- -	128 74 128 75	- -
PT 361 KIT turbomolecular pump system, water-cooled 218-240 V, 50/60 Hz DN 100 ISO-K DN 100 CF DN 160 ISO-K DN 160 CF	- - - -	- - - -	128 76 128 78 upon request upon request
Accessories			
Air cooling unit 230 V 115 V 100 V	854 05 854 06 800152V0015	855 31 894 08 800152V0016	855 31 894 08 800152V0016
Water cooling unit for the TURBOVAC	800135V0003	-	-
Flange heater DN 63 CF, 230 V DN 63 CF, 115 V DN 100 CF, 230 V DN 100 CF, 115 V	854 04 854 07 - -	- - 854 27 -	- - 854 27 854 28
Adsorption trap DN 16 ISO-KF DN 25 ISO-KF	854 14 -	854 14 -	- 854 15
Adsorbent 1.6 l	854 10	854 10	854 10
Exhaust filter AF 4-8 AF 8 AF 16-25	- 190 50 -	189 06 - -	- - 189 11
Venting valve, DN 10 ISO-KF manually operated	173 24	173 24	173 24
Purge gas and venting valve, 230 V 0.2 mbar x l x s ⁻¹	-	855 19 ¹⁾	855 19 ¹⁾
Power failure venting valve 24 V DC, DN 16 ISO-KF 230 V, 50/60 Hz, DN ISO 10 KF	800120V0021 ¹⁾ 174 26 ¹⁾	800120V0021 ¹⁾ 174 26 ¹⁾	800120V0021 ¹⁾ 174 26 ¹⁾
Mains cord US/Japan 230 V, 50/60 Hz CH 230 V, 50/60 Hz UK 230 V, 50/60 Hz	200 81 141 200 81 099 200 81 097	200 81 141 200 81 099 200 81 097	200 81 141 200 81 099 200 81 097
Connecting cable for operating the TURBOVAC outside the pump system 3 m (7.0 ft) 5 m (17.5 ft) 10 m (35.0 ft)	121 08 121 09 -	- 857 66 857 67	- 857 66 857 67

¹⁾ Delivery without connection cable, only with venting function

Dry Pump Systems

PT 80 DRY / PT 80 H DRY Turbomolecular Pump System



Example: PT 80 DRY with scroll pump and options (switchbox, measuring instrument, power failure venting valves and intake section)

The PT 80 DRY turbomolecular pump system is a fully assembled and ready-to-operate high vacuum system designed as a table top unit for producing a high and ultra-high vacuum free of hydrocarbons.

Advantages to the User

- Absolutely oil-free
- Low ultimate pressure free of hydrocarbons (10^{-8} mbar/Torr)
- High effective pumping speed
- Compact, small, rugged unit
- Simple operation
- High level of reliability
- Maintenance-friendly design
- Air cooling
- Installation of standard vacuum components in an open frame
- Service-friendly assembly for maintenance without the need to disassemble backing or high vacuum pump
- The high vacuum pump can be removed (installation in any orientation)

The turbomolecular pump system consists of the following principal components:

- SL 80/SL 80 H wide range turbomolecular pump system featuring
 - Integrated air cooling
 - Ceramic ball bearings
 - Grease lubrication
 - High vacuum connection: DN 63 ISO-K or DN 63 CF
 - Splinter guard at the intake flange
- Frequency converter with start/stop switch
- TURBO.POWER 300 power supply. The power supply supplies the frequency converter with 24 V DC
- Three-stage, absolutely oil-free DIVAC 1.4 HV3 diaphragm vacuum pump respectively scroll pump SCROLLVAC SC 5D as the backing pump
- All required connection and sealing components are located within the pump system assembly

Either with or without switchbox

- With switchbox

The pumps are switched on and off via a rotary switch on the front. Power sockets for accessories (one measuring instrument and one power failure venting valve) are provided. These are connected by means of a power cord with Schuko plug. Other connection lines can be specified also for retrofitting (see Ordering Information)

- Without switchbox

The pumps are switched on and off via switches at the pump, respectively at the frequency converter. For each component a separate earthed mains power outlet is required.

The pump system can be upgraded with further components, for example:

- Switchbox
- Vacuum gauge
- Power failure venting valve
- Rotatable castors
- Venting valve
- Seal gas valve
- Intake assembly with pipe manifold, valves, vacuum gauges etc.

Typical Applications

- Spectroscopy
- Valve manufacturing
- Beam guidance systems
- Micro balances
- Sputtering and evaporation systems
- Surface physics
- Laboratory pump systems

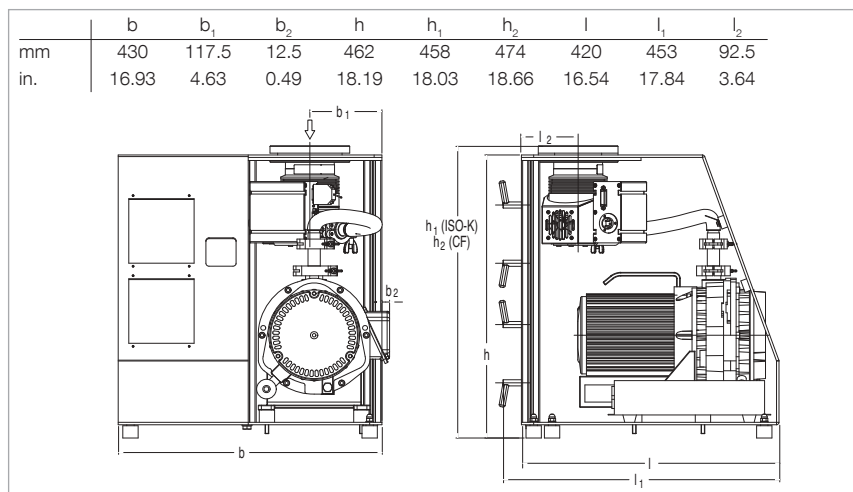

Dimensional drawing for the PT 80 DRY/ PT 80 H DRY turbomolecular pump system

Technical Data

PT 80 H DRY

PT 80 DRY

Wide range turbomolecular pump		TURBOVAC SL 80 H	TURBOVAC SL 80 H	TURBOVAC SL 80	TURBOVAC SL 80
High vacuum connection	DN	63 ISO-K	63 CF	63 ISO-K	63 CF
Pumping speed for N ₂	l x s ⁻¹	65	65	65	65
Diaphragm pump		DIVAC 1.4 HV3	DIVAC 1.4 HV3	-	-
Pumping speed, approx.	m ³ x h ⁻¹ (cfm)	1.3 (0.77)	1.3 (0.77)	-	-
Ultimate pressure	mbar (Torr)	< 1.5 (1.13)	< 1.5 (1.13)	-	-
Scroll vacuum pump		-	-	SCROLLVAC SC 5 D	SCROLLVAC SC 5 D
Pumping speed, approx.	m ³ x h ⁻¹ (cfm)	-	-	5.4 (3.18)	5.4 (3.18)
Ultimate pressure	mbar (Torr)	-	-	< 0.05 (0.03)	< 0.05 (0.03)
Attainable ultimate pressure of the system	mbar (Torr)	10 ⁻⁷ (0.75 x 10 ⁻⁷)	10 ⁻⁸ (0.75 x 10 ⁻⁸)	10 ⁻⁷ (0.75 x 10 ⁻⁷)	10 ⁻⁸ (0.75 x 10 ⁻⁸)
Main supply, 50/60 Hz	V	100 - 230	100 - 230	200 - 230 ¹⁾	200 - 230 ¹⁾
Power consumption, max.					
with diaphragm vacuum pump	VA	420	420	-	-
with scroll vacuum pump	VA	-	-	450	450
Dimensions (W x H x D)	mm (in.)	see dimensional drawing	see dimensional drawing	see dimensional drawing	see dimensional drawing
Weight, approx.					
with diaphragm vacuum pump	kg (lbs)	20 (44.15)	20 (44.15)	-	-
with scroll vacuum pump	kg (lbs)	-	-	28 (61.6)	28 (61.6)

Ordering Information

PT 80 H DRY

PT 80 DRY

	Part No.	Part No.	Part No.	Part No.
PT 80 (H) DRY turbomolecular pump system 230 V, 50 Hz, without switch box, Connection via 2 Schuko plugs with diaphragm vacuum pump with scroll pump	503272V001 -	503273V001 -	- 503225V001	- 503226V001
with switch box and mains cord with 1 Schuko plug with diaphragm vacuum pump with scroll vacuum pump	503272V002 -	503273V002 -	- 503225V002	- 503226V002
Accessories				
Mains adapter Schuko/US	200 11 119	200 11 119	-	-
Mains cord for PT with switch box				
EURO 230 V, 50 Hz	200 81 091	200 81 091	200 81 091	200 81 091
CH 230 V, 50/60 Hz	200 81 099	200 81 099	200 81 099	200 81 099
UK 230 V, 50/60 Hz	200 81 097	200 81 097	200 81 097	200 81 097
US/Japan 230 V, 50/60 Hz	200 81 141	200 81 141	200 81 141	200 81 141
US/Japan 115 V, 60 Hz	200 81 090	200 81 090	- ¹⁾	- ¹⁾
Connection adapter M8 / DN 10 ISO-KF	800110V0011	800110V0011	800110V0011	800110V0011
Power failure venting valve DN 10 ISO-KF 230 V, 50/60 Hz	174 26 ²⁾	174 26 ²⁾	174 26 ²⁾	174 26 ²⁾
Venting valve DN 10 ISO-KF manually operated	173 24	173 24	173 24	173 24
Purge gas and venting valve 100-230 V	800152V0014 ²⁾	800152V0014 ²⁾	800152V0014 ²⁾	800152V0014 ²⁾
Connecting cable for operating the TURBOVAC outside the pump system				
2.5 m (8.75 ft)	864 49	864 49	864 49	864 49
3.0 m (10.50 ft)	864 40	864 40	864 40	864 40
5.0 m (17.50 ft)	864 50	864 50	864 50	864 50
Rotatable castors PT 50/80	503227V901	503227V901	503227V901	503227V901

¹⁾ Other voltages upon request

²⁾ Deliveries in the case of reorders are without connection cable

Turbomolecular Pump System

TURBOLAB 80



Turbomolecular pump system TURBOLAB 80 Basic (left) and TURBOLAB 80 Full Featured (right)

The TURBOLAB 80 turbomolecular pump system is a fully assembled and ready-to-operate high vacuum system designed as a table top unit.

Advantages to the User

- Absolutely oil-free
- Low ultimate pressure free of hydrocarbons (10^{-7} mbar/Torr)
- High effective pumping speed
- Compact and small unit
- Simple operation
- High level of reliability
- Maintenance-friendly design
- Air cooling
- Installation of standard vacuum components in a portable sheet metal enclosure

Only TURBOLAB 80 Basic:

- Manual operation
- Pressure measurement as an option via ITR 90 with display

Only TURBOLAB 80 Full Featured:

- Graphic display of pressure curves
- Menu navigation in different languages
- Parameters of the turbomolecular pump and pressures can be saved to a computer
- ITR 90, PTR 90 or TTR 91 gauge heads can be connected
- Pressure readout through display
- Manual or automatic operation

- Operation parameter indication
- Forevacuum pressure measurement optional (possible)
- Venting is possible (optional)

The turbomolecular pump system consists of the following principal components:

- SL 80 H wide range turbomolecular pump system featuring:
 - Integrated frequency converter
 - Integrated air cooling
 - Ceramic ball bearings
 - Grease lubrication
 - Pumping speed for nitrogen: 65 l x s^{-1}
 - High vacuum connection: DN 63 ISO-K or DN 63 CF
 - Integrated splinter guard
- Frequency converter TURBO.DRIVE TD 400 with interface RS 232 C
- Dual-stage, absolutely oil-free DIVAC 0.8 T diaphragm vacuum pump used as the backing pump with the following specifications:
 - Pumping speed: $0.7 \text{ m}^3 \text{ x h}^{-1}$ (0.41 cfm)
 - Ultimate pressure: $\leq 3 \text{ mbar}$ ($\leq 2.25 \text{ Torr}$)

- All required connection and sealing components are located within the pump system assembly

The pump system is prepared for installation of further components:

- Vacuum gauges
- Venting valve

Automatic operation of the TURBOLAB 80 Full Featured version requires a high vacuum gauge ITR 90 (with or without display), for example and a sensor cable.

The pressure is read out through the display of the pump system. The 24 V DC power supply for operating an ITR 90, respectively PTR 90 gauge is supplied by the pump system.

Typical Applications

- Spectroscopy
- Valve manufacturing
- Beam guidance systems
- Micro balances
- Sputtering and evaporation systems
- Surface physics
- Laboratory pump systems

Technical Data

TURBOLAB 80 Basic

TURBOLAB 80 Full Featured

Hybrid turbomolecular pump		TURBOVAC SL 80 H	TURBOVAC SL 80 H
High vacuum connection	DN	63 ISO-K / 63 CF	63 ISO-K / 63 CF
Pumping speed for N ₂	l x s ⁻¹	65	65
Diaphragm pump		DIVAC 0.8 T	DIVAC 0.8 T
Pumping speed, approx.	m ³ x h ⁻¹ (cfm)	0.7 (0.41)	0.7 (0.41)
Ultimate pressure, approx.	mbar (Torr)	3 (2.25)	3 (2.25)
Attainable ultimate pressure	mbar (Torr)	10 ⁻⁷ (0.75 x 10 ⁻⁷)	10 ⁻⁷ (0.75 x 10 ⁻⁷)
Run-up time, approx.	min	1.5	1.5
Main supply, 50/60 Hz	V	88 to 264	88 to 264
Power consumption, max.	VA	350	350
Dimensions (W x H x D)	mm (in.)	see dimensional drawing	see dimensional drawing
Weight, approx.	kg (lbs)	14.5 (32.01)	14.5 (32.01)

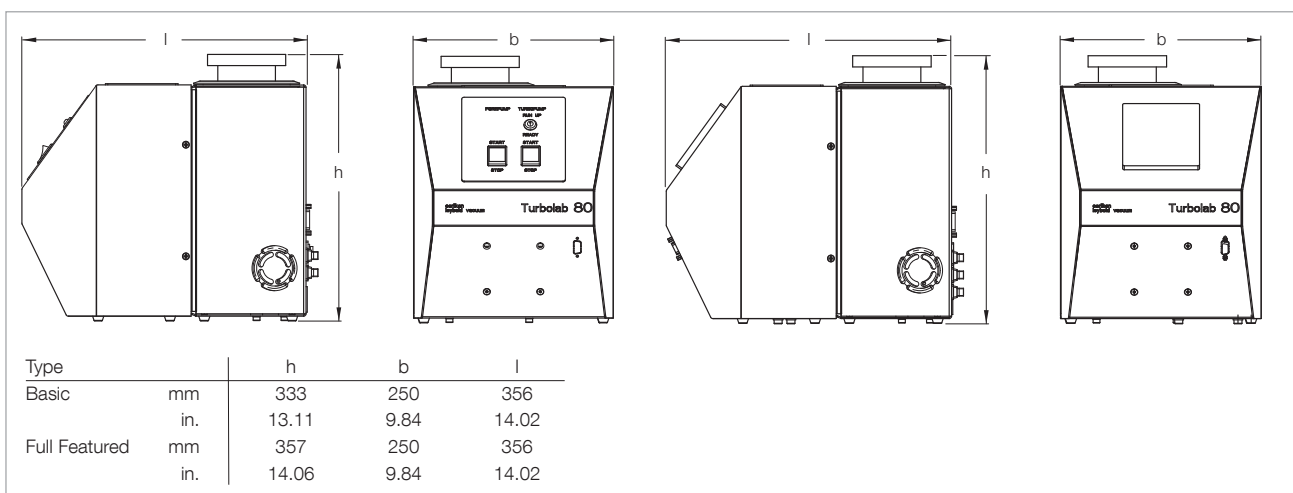

Dimensional drawing for the turbomolecular pump system TURBOLAB 80 Basic (left) and TURBOLAB 80 Full Featured (right)

Ordering Information

TURBOLAB 80 Basic

	Part No. 501590	V			0	
High vacuum connection DN 63 ISO-K DN 63 CF	1		_____	↑		
	2		_____	↑		
Sensor without sensor, without cable	0		_____	↑		
ITR 90/DN 25 ISO-KF with display and 5 m (17.5 ft) cable	1		_____	↑		
ITR 90/DN 40 CF with display and 5 m (17.5 ft) cable	2		_____	↑		
Venting valve without venting valve in the forevacuum line	0		_____	↑		
with venting valve in the forevacuum line	1		_____	↑		

TURBOLAB 80 Full Featured

	Part No. 501591	V				
High vacuum connection DN 63 ISO-K DN 63 CF	1		_____	↑		
	2		_____	↑		
Sensor without sensor, without cable	0		_____	↑		
ITR 90/DN 25 ISO-KF with display and 5 m (17.5 ft) cable	1		_____	↑		
without display and 5 m (17.5 ft) cable	2		_____	↑		
ITR 90/DN 40 CF with display and 5 m (17.5 ft) cable	3		_____	↑		
without display and 5 m (17.5 ft) cable	4		_____	↑		
PTR 90/DN 25 ISO-KF with cable and adapter	5		_____	↑		
PTR 90/DN 40 ISO-KF with cable and adapter	6		_____	↑		
PTR 90/DN 40 CF with cable and adapter	7		_____	↑		
Forevacuum sensor without sensor in the forevacuum line	0		_____	↑		
with sensor TTR 91 in the forevacuum line	1		_____	↑		
Venting valve without venting valve in the forevacuum line	0		_____	↑		
with venting valve in the forevacuum line	1		_____	↑		

Parts for Converting/Expanding Existing Systems

Ordering Information

TURBOLAB 80 Basic

TURBOLAB 80 Full Featured

	Part No.	Part No.
Venting valve (retrofit kit)		
24 V DC, normally open	650 49 11	-
24 V DC, normally closed	-	650 48 99
Sensor ITR 90		
DN 25 ISO-KF		
without display	-	120 90
with display	120 91	120 91
DN 40 CF		
without display	-	120 92
with display	120 94	120 94
ITR sensor cable, 5 m (17.5 ft)	124 55	124 55
Sensor PTR 90		
DN 25 ISO-KF	-	230 070
DN 40 ISO-KF	-	230 071
DN 40 CF	-	230 072
PTR sensor cable, 5 m (17.5 ft) ¹⁾	-	124 26
Adapter cable TURBOLAB 80/PTR sensor ¹⁾	-	650 41 12
Forevacuum sensor TTR 91		
1/2" tube	-	230 039
Mains cable, 3 m (10.5 ft)		
with EURO plug ²⁾	800102V0002	800102V0002
with UK plug	800102V0003	800102V0003
with US plug 5-15P	800102V1002	800102V1002

¹⁾ Required for fitting a PTR 90

²⁾ Included in the delivery

PT 151 DRY / PT 361 DRY Turbomolecular Pump Systems



Example: PT 361 DRY with scroll pump and options (measuring instrument, forevacuum valve)

These turbomolecular pump systems are ready-to-operate vacuum units for generating a vacuum in the high and ultra-high vacuum range which is free of hydrocarbons.

When pumping aggressive or abrasive process gases, a purge gas facility must be used for the pumps.

Advantages to the User

- Low ultimate pressure free of hydrocarbons ($< 10^{-10}$ mbar/Torr)
 - High backing pump pumping speed
 - High effective pumping speed
 - Compact, mobile unit
 - Simple to operate
 - High level of reliability
 - Venting port
 - Purge gas port (only at C version)
 - Service friendly assembly for maintenance without the need to disassemble backing or high vacuum pump
 - Pump systems prepared for installation of larger backing pumps (for barrier gas operation, for example)
 - CE approval
- The turbomolecular pump systems consists of the following principal components:**
- Grease lubricated turbomolecular pump TURBOVAC 151 or 361 with splinter guard
 - Electronic frequency converter TD 20^{classic}

- Dry compressing scroll pump SCROLLVAC SC 15 D or SC 30 D (further sizes upon request)
- All necessary connection and sealing components within the pump system
- **Either with or without switchbox**
 - *With switchbox*
The pumps are switched on and off via a rotary switch on the front. Power sockets for accessories (Gauge, power failure venting valve, air cooler and flange heater) are provided. These are connected by means of a power cord with Schuko plug. Other connection lines can be specified also for retrofitting
 - *Without switchbox*
The pumps are switched on and off via switches at the pump, respectively at the frequency converter. For each component a separate earthed mains power outlet is required.

The pump systems can be upgraded with further components,- for example:

- Switch box
- Vacuum gauges (up to two)
- Exhaust filter
- Air cooling unit
- Flange heater
- Power failure venting valve
- Venting valve
- Purge gas valve (only at C version)
- Intake arrangement with manifold, valves, vacuum gauges etc.

Typical Applications

- Spectroscopy
- Tube manufacturing
- Beam guidance systems
- Microbalances
- Sputtering and evaporation systems
- Surface physics

Technical Data

PT 151 DRY

PT 361 DRY

Turbomolecular pump	TURBOVAC	151	151	361	361
High vacuum connection	DN	100 ISO-K	100 CF	100 ISO-K	100 CF
Pumping speed for N ₂	l x s ⁻¹	145	145	345	345
Compression for N ₂ /H ₂		> 10 ⁹	8.5 x 10 ²	> 10 ⁹	3.5 x 10 ³
Speed of the TURBOVAC	rpm	50 000	50 000	50 000	50 000
Scroll vacuum pump	SCROLLVAC	SC 5 D	SC 5 D	SC 15 D	SC 15 D
Nominal pumping speed (DIN 28 400)	m ³ x h ⁻¹ (cfm)	5.4 (3.18)	5.4 (3.18)	15.0 (8.83)	15.0 (8.83)
Exhaust connection	DN	16 ISO-KF	16 ISO-KF	25 ISO-KF	25 ISO-KF
Attainable ultimate pressure with FPM (FKM) gasket	mbar (Torr)	10 ⁻⁸ (0.75 x 10 ⁻⁹)	10 ⁻⁸ (0.75 x 10 ⁻⁹)	10 ⁻⁸ (0.75 x 10 ⁻⁹)	10 ⁻⁸ (0.75 x 10 ⁻⁹)
with Cu seal	mbar (Torr)	–	10 ⁻¹⁰ (0.75 x 10 ⁻¹⁰)	–	10 ⁻¹⁰ (0.75 x 10 ⁻¹⁰)
Cooling water consumption	l/h	15-35	15-35	15-35	15-35
Cooling water connection, hose nozzle, outside dia.	mm (in.)	10 (0.39)	10 (0.39)	10 (0.39)	10 (0.39)
Power consumption, max.	VA	550	550	800	800
Mains supply 50/60 Hz	V	200-230 ¹⁾	200-230 ¹⁾	200-230 ¹⁾	200-230 ¹⁾
Dimensions (W x H x D)	mm (in.)	see dimensional drawing	see dimensional drawing	see dimensional drawing	see dimensional drawing
Weight, approx.	kg (lbs)	51 (112.6)	51 (112.6)	80 (176.6)	80 (176.6)

¹⁾ Other voltages upon request

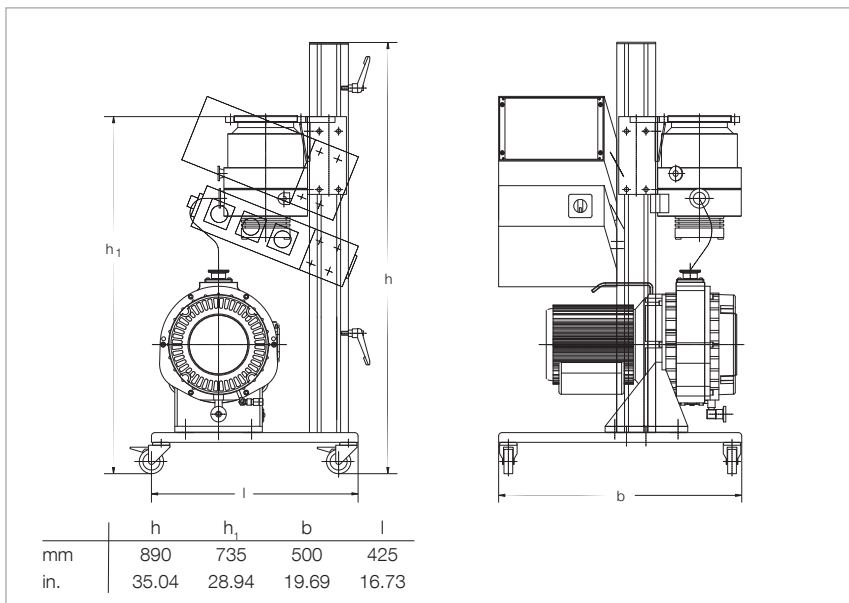

Dimensional drawing for the PT 151 DRY / PT 361 DRY turbomolecular pump systems with scroll vacuum pump SCROLLVAC and optional switch box

Technical Data
PT 151 DRY
PT 361 DRY

	Part No.	Part No.	Part No.	Part No.
Turbomolecular pump system 230 V, 50 Hz ¹⁾ , without switch box, connection via 2 Schuko plugs with SC 5 D	100 ISO-K 503274V001	100 CF 503275V001	100 ISO-K -	100 CF -
230 V, 50 Hz ¹⁾ , with switch box and mains cord with 1 Schuko plug with SC 5 D with SC 15 D	 503274V002 -	 503275V002 -	 - 503276V001	 - 503277V001
Accessories				
Air cooling unit 100 V 115 V 230 V	800152V0016 894 08 855 31	800152V0016 894 08 855 31	800152V0016 894 08 855 31	800152V0016 894 08 855 31
Flange heater, DN 100 CF 115 V 230 V	- -	854 28 854 27	- -	854 28 854 27
Venting valve, DN 10 ISO-KF manually operated	173 24	173 24	173 24	173 24
Power failure venting valve normally open 24 V DC, DN 16 ISO-KF 230 V, 50/60 Hz, DN 10 ISO-KF	800120V0021 ²⁾ 174 26 ²⁾	800120V0021 ²⁾ 174 26 ²⁾	800120V0021 ²⁾ 174 26 ²⁾	800120V0021 ²⁾ 174 26 ²⁾
Purge gas and venting valve, 100-230 V 0.4 mbar x l x s ⁻¹	800152V0014 ²⁾	800152V0014 ²⁾	800152V0014 ²⁾	800152V0014 ²⁾
Filter adapter for gas connection G 1/4"	800110V0012	800110V0012	800110V0012	800110V0012
Replacement filter	200 18 515	200 18 515	200 18 515	200 18 515
Mains cord for PT with switch box EURO 230 V, 50 Hz CH 230 V, 50/60 Hz UK 230 V, 50/60 Hz US/Japan 230 V, 50/60 Hz	200 81 091 200 81 099 200 81 097 200 81 141	200 81 091 200 81 099 200 81 097 200 81 141	200 81 091 200 81 099 200 81 097 200 81 141	200 81 091 200 81 099 200 81 097 200 81 141
Control unit for turbomolecular pump systems (see Chapter "Accessories")	upon request	upon request	upon request	upon request

¹⁾ Other voltages upon request

²⁾ Deliveries in the case of reorders are without connection cable, purge gas only at C-versions

PT 300 DRY Turbomolecular Pump System



Example: PT 300 DRY with switch box

The PT 300 DRY turbomolecular pump system is a fully assembled, ready-to-operate and mobile vacuum pump system which is based on a column design for processes which require hydrocarbon-free high and ultra-high vacuum.

Advantages to the User

- Absolutely oil-free
- Low ultimate pressure free of hydrocarbons (10^{-9} mbar/Torr)
- High effective pumping speed
- Compact, mobile unit
- Simple operation
- High level of reliability
- Maintenance-friendly design
- Installation in any orientation for SL 300
- Air cooling
- Installation of standard vacuum components in an open frame with installation column and castors
- Service-friendly assembly for maintenance without the need to disassemble backing or high vacuum pump
- Pump systems prepared for installation of larger backing pumps

The turbomolecular pump system consists of the following principal components:

- SL 300 wide range turbomolecular pump
- Air cooling unit
- Frequency converter TD 400 with Start/Stop switch
- TURBO.POWER 300 power supply unit
- Absolutely oil-free scroll pump SCROLLVAC SC 5D as the backing pump (other sizes upon request)
- Mobile base plate with column
- All required connection and sealing components are located within the pump system assembly

- Either with or without switchbox

- With switchbox

The pumps are switched on and off via a rotary switch on the front. Power sockets for accessories (measuring instrument, power failure venting valve and flange heater) are provided. These are connected by means of a power cord with Schuko plug. Other connection lines can be specified also for retrofitting

- Without switchbox

The pumps are switched on and off via switches at the pump, respectively at the frequency converter. For each component a separate earthed mains power outlet is required.

The pump system can be upgraded with further components, for example:

- Switch box
- Vacuum gauges (up to two)
- Exhaust filter
- Flange heater
- Power failure venting valve
- Venting valve
- Purge gas valve

Typical Applications

- Spectroscopy
- Valve manufacturing
- Beam guidance systems
- Micro balances
- Sputtering and evaporation systems
- Surface physics
- Laboratory pump systems

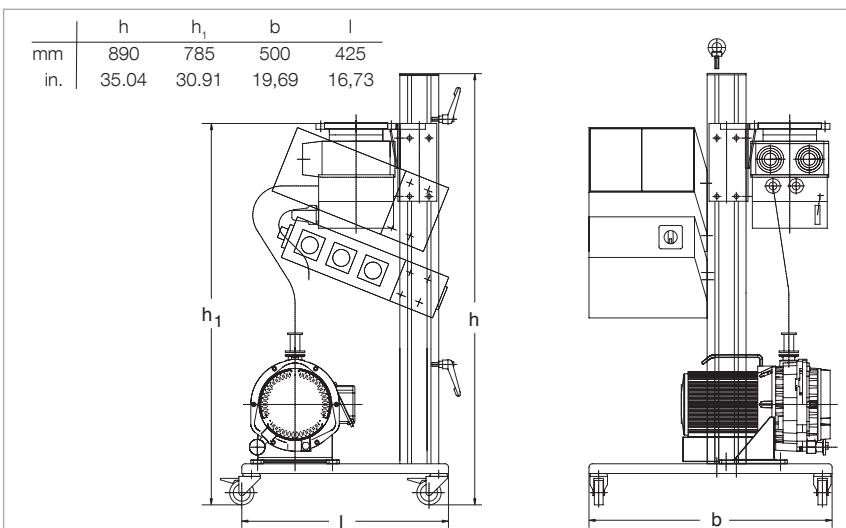

Dimensional drawing for the PT 300 DRY turbo molecular pump system with switch box

Technical Data

PT 300 DRY

Wide range turbomolecular pump High vacuum connection Pumping speed for N ₂	DN l x s ⁻¹	TURBOVAC SL 300 100 ISO-K 270	TURBOVAC SL 300 100 CF 270
Scroll vacuum pump Pumping speed, approx. Ultimate pressure, approx.	m ³ x h ⁻¹ (cfm) mbar (Torr)	SCROLLVAC SC 5 D 5.4 (3.18) < 0.05 (0.03)	SCROLLVAC SC 5 D 5.4 (3.18) < 0.05 (0.03)
Attainable ultimate pressure with FPM (FKM) gasket with Cu seal	mbar (Torr) mbar (Torr)	10 ⁻⁸ (0.75 x 10 ⁻⁸) -	10 ⁻⁸ (0.75 x 10 ⁻⁸) 10 ⁻⁹ (0.75 x 10 ⁻⁹)
Main supply, 50/60 Hz	V	230 / 115	230 / 115
Power consumption, max.	VA	450	450
Dimensions (W x H x D)	mm (in.)	see dimensional drawing	see dimensional drawing
Weight, approx.	kg (lbs)	45 (99.21)	45 (99.21)

Ordering Information

PT 300 DRY

	Part No.	Part No.
PT 300 DRY turbomolecular pump system 230 V, 50/60 Hz ¹⁾ , without switch box, connection via 2 Schuko plugs DN 100 ISO-K DN 100 CF	503278V001 -	- 503279V001
230 V, 50/60 Hz ¹⁾ , with switch box and mains cord with 1 Schuko plug DN 100 ISO-K DN 100 CF	503278V002 -	- 503279V002

Accessories

Water cooling unit	800135V0002	800135V0002
Flange heater for flange DN 100 CF 115 V 230 V	- -	854 28 854 27
Power failure venting valve 24 V DC, DN 16 ISO-KF 230 V, 50/60 Hz, DN 10 ISO-KF	800120V0021 ²⁾ 174 26 ²⁾	800120V0021 ²⁾ 174 26 ²⁾
Connection adapter M8 / DN 10 ISO-KF	800110V0011	800110V0011
Purge gas and venting valve, 0.2 mbar x l x s ⁻¹ at 1 bar 24 V DC 100-230 VAC	113 50 ²⁾ 800152V0019 ²⁾	113 50 ²⁾ 800152V0019 ²⁾
Copper sealing rings for CF flanges (set of 10 pieces)	-	839 45
Mains cord for PT with switch box EURO 230 V, 50 Hz CH 230 V, 50/60 Hz UK 230 V, 50/60 Hz US/Japan 230 V, 50/60 Hz	200 81 091 200 81 099 200 81 097 200 81 141	200 81 091 200 81 099 200 81 097 200 81 141
24 V DC mains cord 3 m (7.0 ft) 5 m (17.5 ft) 10 m (35.0 ft) 20 m (70.0 ft)	800094V0300 800094V0500 800094V1000 800094V2000	800094V0300 800094V0500 800094V1000 800094V2000
Control unit for turbomolecular pump systems (see Chapter "Accessories")	upon request	upon request

¹⁾ Other voltages upon request

²⁾ Deliveries in the case of reorders are without connection cable

Only available for purchase in North and South America

PT-FLEX DRY Turbomolecular Pump System



PT-FLEX pumping systems provide unique flexibility, allowing the user to define the optimum combination of performance and price.

PT-FLEX pump systems are offered with three sizes Compound Turbo-molecular pumps, three sizes dry scroll backing pumps, a basic or full-featured system controller and the ability to incorporate and control multiple valves, vacuum gauges, flange heaters and other peripheral equipment.

PT-FLEX systems can be specially configured with classic turbo pumps and rotary vane forevacuum pumps. Please consult Oerlikon Leybold Vacuum for details.

Advantages to the User

- Oil-free high vacuum
- Compact, mobile
- Air-cooled
- Adjustable height
- Fully assembled and tested

Configuration and Capabilities

- Three sizes turbo pump
- Three sizes dry scroll forevacuum pump
- Manual or powered height adjustment
- Ability to power and control multiple peripheral devices (sold separately)
- Basic or full-featured TSC system controller
- Allows mounting of one or two rack gauge controllers

PT-FLEX with BASIC Controller

- Mains ON/OFF
- Mains switch activated 115 V AC output for use with vent valve or gauge controller
- Start / Stop switch for both pumps
- Manual control and power for
 - Pumps
 - Vent valves
 - Vacuum isolation valves
 - Flange heater
- Provides additional 115 V AC and 24 V DC outputs to power additional peripheral devices
- Vacuum Ion Gauge degas function for gauge model ITR 90
- Turbo operation indicator

PT-FLEX with TSC Controller

(see separate catalog page for in-depth description of features and capabilities)

- One button auto system control
- Monitors and displays all turbo pump operating and diagnostic parameters
- Acts as display for up to 3 "smart" vacuum gauge sensors
- All features of PT-Flex BASIC controller
- Additional power and control capabilities for peripheral equipment

Technical Data

PT-FLEX

Turbomolecular pump High vacuum connection	DN	TURBOVAC SL 80 63 ISO-K 63 CF	TURBOVAC SL 300 100 ISO-K 100 CF
Backing pumps		SCROLLVAC SC 5 D	SCROLLVAC SC 5 D SCROLLVAC SC 15 D
Cooling		Air	Air (water option)
Max. current requirements (dependent on forepump)	V AC Phase Hz A	115 1 50/60 15	115 1 50/60 15
Controller		<p>TSC Turbo System Controller AUTO operation with gauge selection or Manual TW monitoring status Gauge sensor display with smart gauge selection</p> <p>Accessory Control Inlet, foreline and roughing valve Vent/purge valve Flange heater (CF flange only) Ion sensor degas</p> <p>Basic System Controller Manual Start/Stop operation</p> <p>Accessory Control Vacuum valve Vent valve Flange heater (CF flange only) Ion sensor degas Column height adjustment (option)</p>	

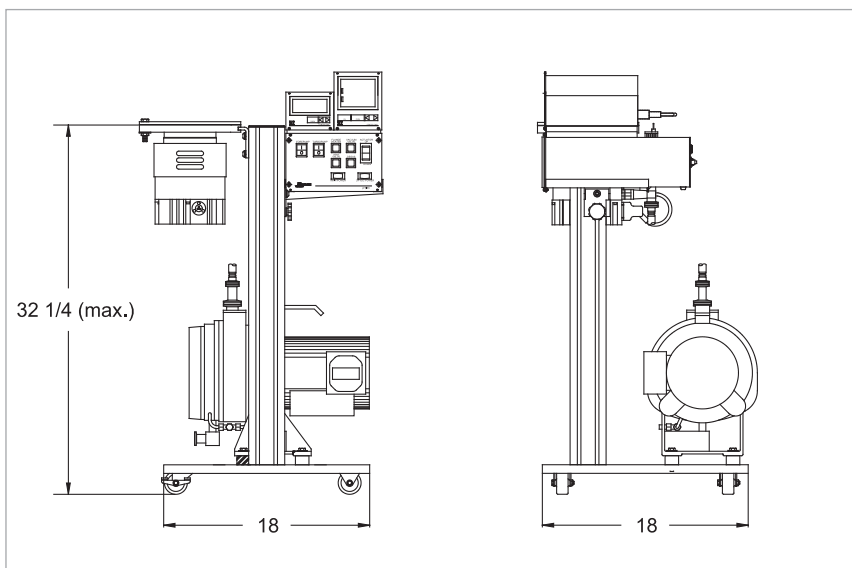

Dimensional drawing for the PT-Flex (manual post)

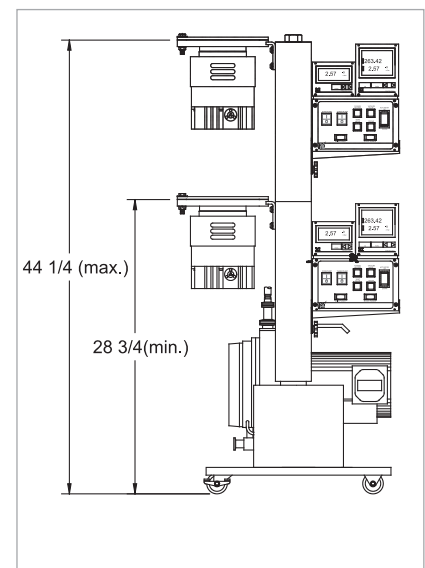

Dimensional drawing (front view) for the PT-Flex (powered support)

Ordering Information

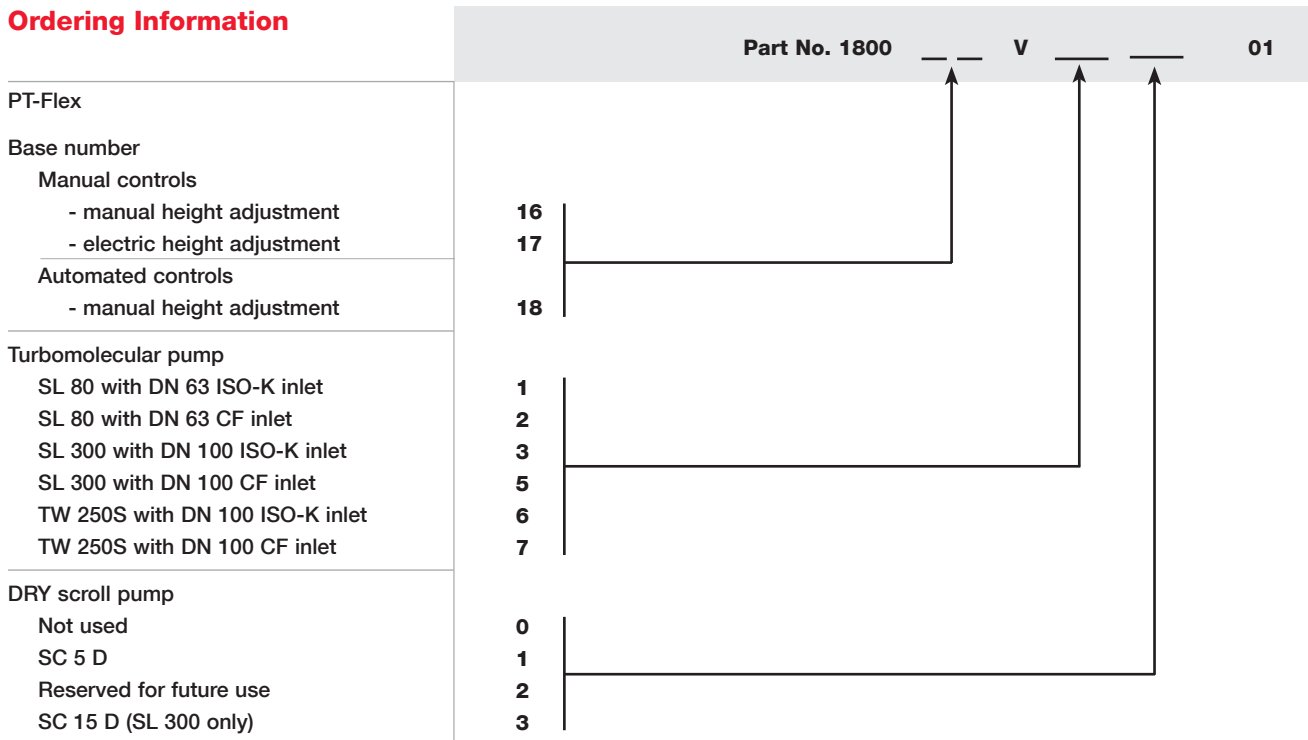

Accessories for High Vacuum Pump Systems TMP

Control Unit for Turbomolecular Pump Systems



Control unit for turbomolecular pump systems

The control unit is suited for operation in connection with turbomolecular pump systems PT 50, PT 80 DRY, PT 151/361, PT 151/361 DRY, PT 300 DRY; as well as custom pump systems.

The graphic monochrome display with its blue LED backlight offers excellent visibility also under difficult conditions.



Control unit installed in the PT 80 DRY pump system

Advantages to the User

- Either automatic/manual operation
- Pressure readout for forevacuum and high vacuum is possible
- Selectable pressure units: mbar, torr, Pa
- Graphic display of the pressure curve
- Connectable high vacuum sensors: PTR and ITR
- Setting up the cut-in pressure for the turbomolecular pump is possible
- Venting of the pump system through a delayed venting function
- Memory card for recording data is connectable
- Data recording through a PC is possible
- Menu navigation in different languages

Ordering Information

Control Unit for Turbomolecular Pump Systems

	Part No.
Control unit for turbomolecular pump systems	upon request

Adsorption Traps with Aluminium Oxide Insert

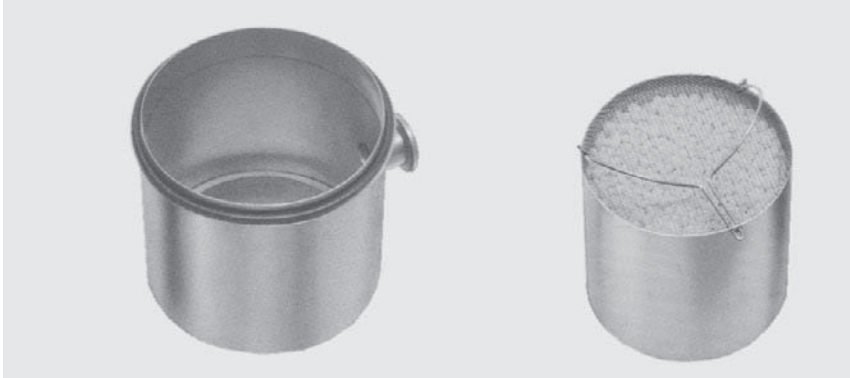

Adsorption trap (left) and insert (right)

Adsorption traps are installed in all those cases where an oil-free vacuum is to be produced with oil-sealed vacuum pumps.

Advantages to the User

- Backstreaming of oil is reduced by 99%
- Long service life
- High conductance
- Filling can be easily exchanged
- Improvement in the ultimate pressure attained by backing pumps by one order of magnitude
- Stainless steel housing and insert
- NBR gasket

Typical Applications

- Product of an oil-free vacuum

Supplied Equipment

- Complete with insert
- Without adsorbent

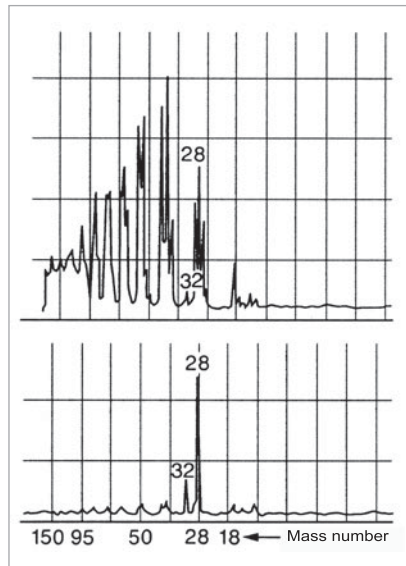

Residual gas spectrum; top ahead of a rotary vacuum pump, bottom ahead of a rotary vacuum pump with adsorption trap

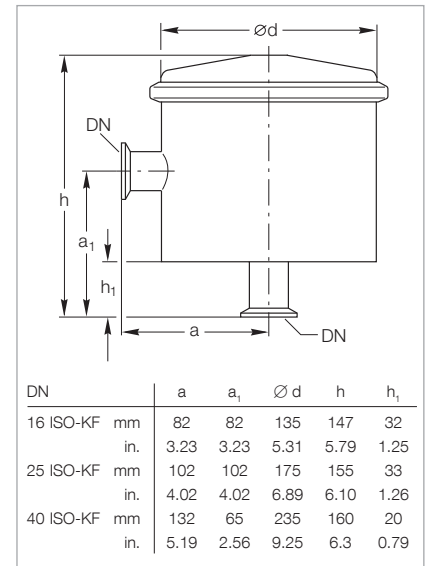

Dimensional drawing for the adsorption traps

Technical Data

		Adsorption Traps		
		16 ISO-KF	25 ISO-KF	40 ISO-KF
Conductance at 10 ⁻² mbar (Torr)	l x s ⁻¹	4.0	6.0	12.0
Service live with Al oxide	Months	3	3	3
Al oxide filling	l (qts)	0.5 (0.53)	1.0 (1.06)	2.0 (2.1)
Weight, approx.	kg (lbs)	1.3 (2.9)	1.3 (2.9)	4.0 (8.8)

Ordering Information

		Adsorption Traps		
		16 ISO-KF	25 ISO-KF	40 ISO-KF
		Part No.	Part No.	Part No.
Adsorption trap		854 14	854 15	854 16
Activated aluminum oxide in tin 1.6 l (approx. 1.2 kg (2.65 lbs))		854 10	854 10	854 10

UNIVEX High Vacuum Experimentation Systems

General

The UNIVEX system family was developed by Oerlikon Leybold Vacuum for applications in research and development as well as for setting up pilot production units.

Their range of applications focuses chiefly on vacuum coating technology as well as vacuum process engineering experiments. The multi-purpose experimentation systems from Oerlikon Leybold

Vacuum are modular and can be specified according to specific customer requirements. For this purpose, a corresponding questionnaire is provided on the last pages of this chapter.

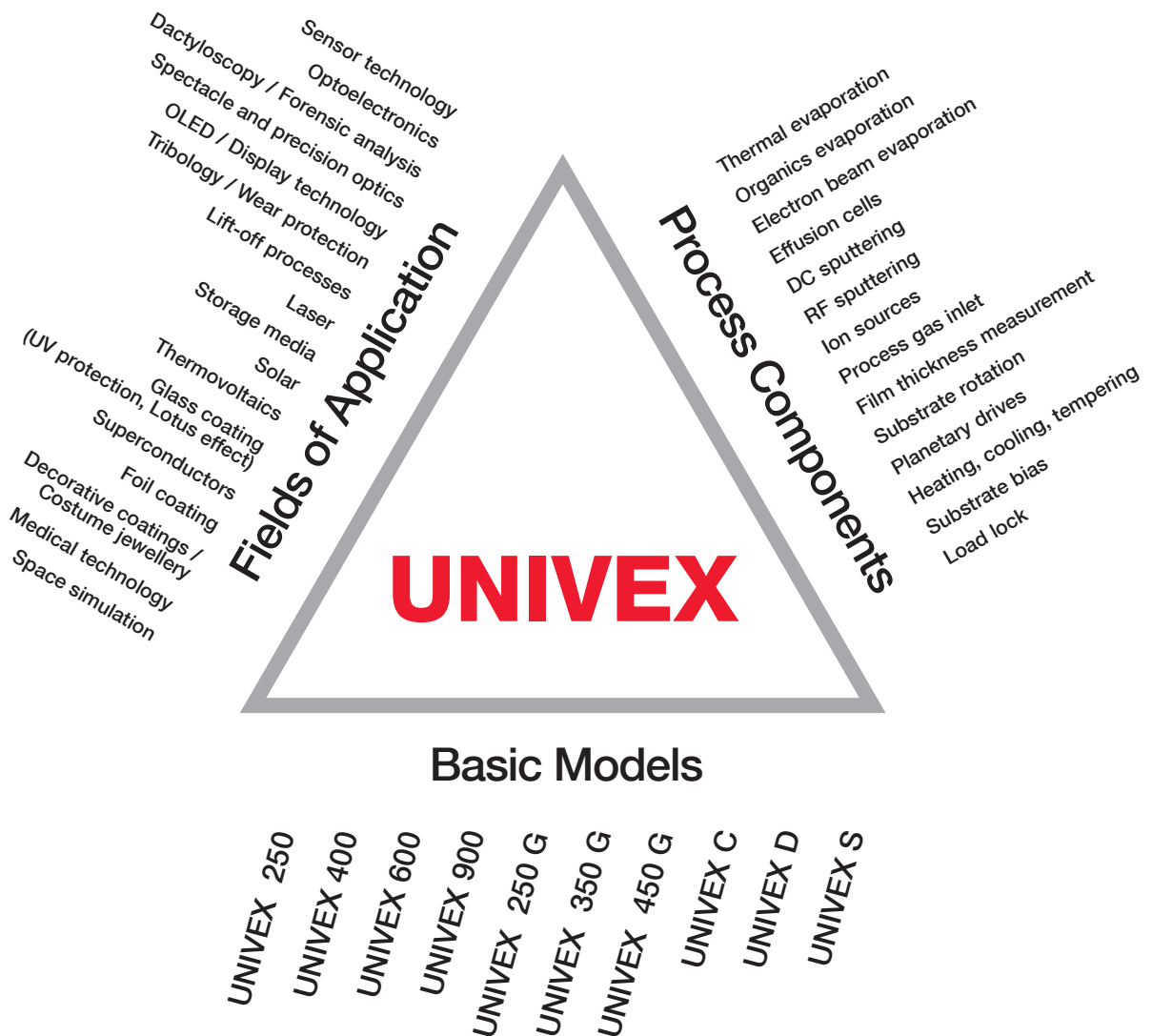

Contents

General

General	627
Contents	628

Systems

Box Coating Systems	629
Glove Box Systems	638
Cluster-Tool Systems	644
Dactyloscopy Systems	646
Space Simulation Systems	647

Process Accessories

Thermal Evaporation of High Melting Point Materials (metals)	648
Thermal Evaporation of Low Melting Point Materials (organic)	650
Electron Beam Evaporation	651
Sputtering	652
Ion Sources	653
Process Gas Inlet	654
Film Thickness Measurement	655
Substrate Rotation	656
Planetary Drives	656
Heating, Cooling, Tempering, Bias	657
Load Lock Systems	659

General Accessories

Blank-Off Screw Fitting	660
Low Pressure Safety Switch	660
Overpressure Safety Valve	660
Vacuum Feedthrough	661
Pneumatically Actuated Swivelling Shutter	661
UNIVEX Questionnaire	662

Box Coating Systems

Multi-purpose Vacuum Coating System for the Laboratory

Design

- Compact unit with direct access to the process chamber
- The UNIVEX box coating systems consist of a process and a control module
- The process module includes the vacuum chamber, the coating components and the pump system
- The control module includes the PLC, respectively PC controller including the visualisation as well as the power supplies for the process components

Vacuum Chamber

- Box-shaped stainless steel vacuum chambers UNIVEX 250-600
- Octagonal stainless steel vacuum chamber UNIVEX 900
- Swivelling front door for simple chamber access
- Viewing window with coating protection
- Removable stainless steel coating protection panels
- Flexible connections for chamber bottom and chamber top
- Connecting flanges for pump system and process components
- Coolable and heatable chamber walls optional

Vacuum System

- Mechanical forevacuum pump (dry compressing or oil sealed)
- High vacuum pump (turbomolecular or cryo pump)
- Vacuum valves
- Pressure measurement devices

Advantages to the User

- Modular system design
- Application-wise optimised pump system
- Multi-purpose vacuum chamber
- Convenient access to the chamber installations
- Very simple to operate and use via programmable control
- Suited for retrofitting of process components (configuration dependent)
- For installation into clean-room walls

Basic Models

UNIVEX 250



UNIVEX 400



UNIVEX 600



UNIVEX 900



UNIVEX 250



Design example UNIVEX 250

The UNIVEX 250 is a cost-effective and compact entry-level coating system for the laboratory.

Owing to its low height of only approximately 1.2 meters it is ideally placed on a benchtop or installed in a frame.

In the vacuum chamber which is 250 mm wide, substrates up to an overall diameter of 220 mm max. can be rotated and coated.

The integrated PLC controller allows you to run manual, respectively semi-automatic coating processes.

Examples of Equipped Vacuum Chambers



Chamber bottom:
double thermal evaporator with source shutter
Chamber top:
rotating substrate table with substrate shutter

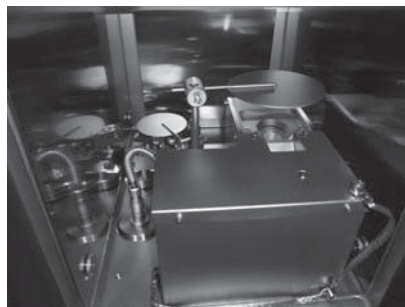

Electron beam evaporator with fourfold rotating crucible as well as additional double thermal evaporator, each with source shutter



Effusion cell as well as spare blank flanges for subsequent retrofits

Technical Data

UNIVEX 250

Vacuum chamber		
Material		
Chamber body		Stainless steel
Chamber door		Aluminum
Dimensions		
Inside width	mm	270
Inside depth	mm	370
Inside height	mm	400
Connections ¹⁾		
Front side		Door with window
Rear side	DN	1x 160 ISO-K (pump system connection), 2 x 16 ISO-KF, 1 x 25 ISO-KF, 2 x 40 ISO-KF
Bottom plate		Variable connections
Cover plate		1 x 200 ISO-K, 4x installation bore ø 34,5 mm
High vacuum pump		TURBOVAC 350 i
Nominal pumping speed for N ₂	l x s ⁻¹	290
Backing pump		SOGEVAC SV 10 B
Nominal pumping speed	m ³ x h ⁻¹	11
Controller		PLC with graphic touchscreen
Required supplies		
Voltage		400 V, 3 phases / N / 50 Hz ²⁾
Cooling water		
Inlet pressure	bar (abs.)	4 to 6
Consumption, approx.	l x min ⁻¹	Dependent on chamber installations
Feed temperature	°C	+18 to +25
Compressed air		
	bar (abs.)	4 to 6
Weight, approx.	kg	300 ³⁾

¹⁾ Standard configuration, other hole patterns / flanges / viewing windows upon request

²⁾ Other voltages and frequencies upon request

³⁾ Total weight without chamber installations/process components

Ordering Information

UNIVEX 250

	Part No.
UNIVEX 250	upon request

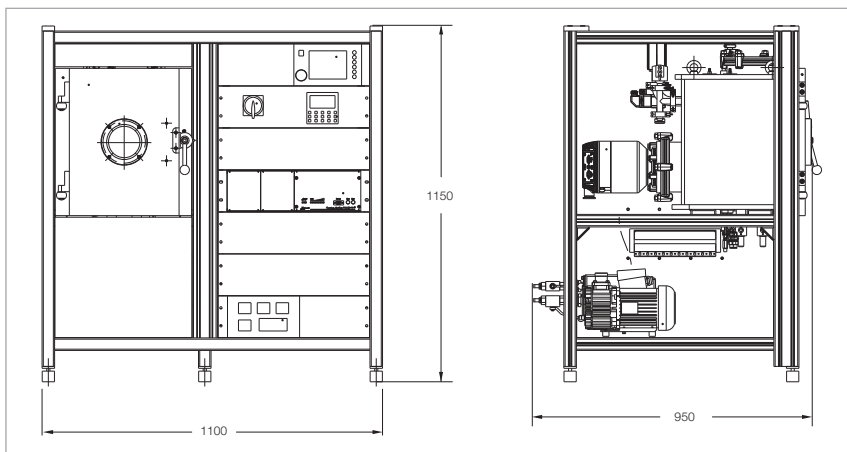

Dimensional drawing for the UNIVEX 250

UNIVEX 400



Design example UNIVEX 400

The UNIVEX 400 is a compact coating system for laboratory tasks, respectively pilot production runs.

Due to its chamber dimensions, it is ideal for coating of small to medium-sized substrates.

In the vacuum chamber which is 420 mm wide, substrates respectively substrate holders up to an overall diameter of 350 mm max. can be rotated and coated.

The integrated PC/PLC controller allows you to run manual, semiautomatic and fully automatic coating processes.

Examples of Equipped Vacuum Chambers



Two magnetron sputter sources, confocal aligned to the substrate holder rotating at the chamber top. Spare flanges for two further sputter sources

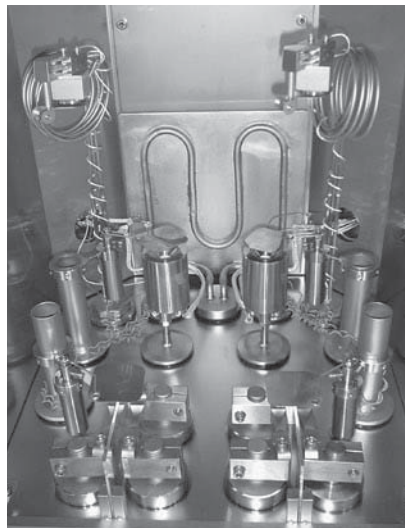

At the foreground: two double thermal evaporators with source shutters
In the background: two organics evaporators with source shutters and two film thickness gauge heads



Rotating, resistively heated substrate table with shutters and thin film gauge head

Technical Data

UNIVEX 400

Vacuum chamber		Water-cooled
Material		
Chamber body		Stainless steel
Chamber door		Stainless steel
Dimensions		
Inside width	mm	420
Inside depth	mm	420
Inside height	mm	550
Connections ¹⁾		
Front side		Door with window
Rear side	DN	1x 160 ISO-K (pump system connection), 2 x 16 ISO-KF, 2 x 40 ISO-KF, 2 x 40 ISO-KF
Bottom plate		Variable connections
Cover plate		1 x 250 ISO-K, 4x installation bore ø 34,5 mm
High vacuum pump		TURBOVAC 450 i
Nominal pumping speed for N ₂	l x s ⁻¹	430
Backing pump		SOGEVAC SV 25 B
Nominal pumping speed	m ³ x h ⁻¹	26
Controller		PLC with graphic touchscreen
Required supplies		
Voltage		400 V, 3 phases / N / PE / 50 Hz ²⁾
Cooling water		
Inlet pressure	bar (abs.)	4 to 6
Consumption, approx.	l x min ⁻¹	Dependent on chamber installations
Feed temperature	°C	+18 to +25
Compressed air	bar (abs.)	4 to 6
Weight, approx.	kg	500 ³⁾

¹⁾ Standard configuration, other hole patterns / flanges / viewing windows upon request

²⁾ Other voltages and frequencies upon request

³⁾ Total weight without chamber installations/process components

Ordering Information

UNIVEX 400

	Part No.
UNIVEX 400	upon request

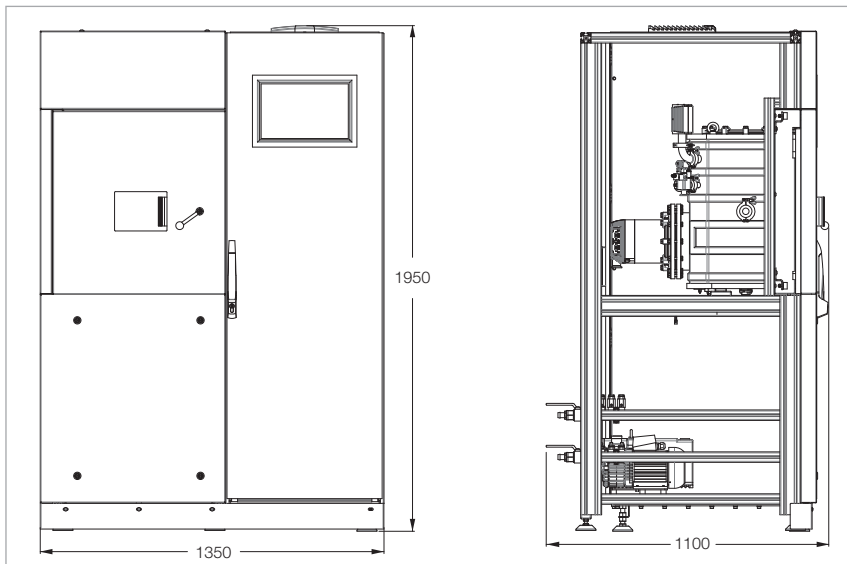

Dimensional drawing for the UNIVEX 400

UNIVEX 600



Design example UNIVEX 600

The UNIVEX 600 is a compact coating system for the laboratory, respectively pilot production runs.

Because of its chamber size it is suited for medium to large substrate sizes.

The attainable substrate throughput meets the general requirements for small series production runs.

In the vacuum chamber which is 600 mm wide, substrates respectively substrate holders up to an overall diameter of 550 mm max. can be rotated and coated.

The integrated PC/PLC controller allows you to run manual, semiautomatic and fully automatic coating processes.

Examples of Equipped Vacuum Chambers



Chamber bottom: electron beam evaporator with sixfold rotating crucible
Chamber top: planetary drive for substrate rotation

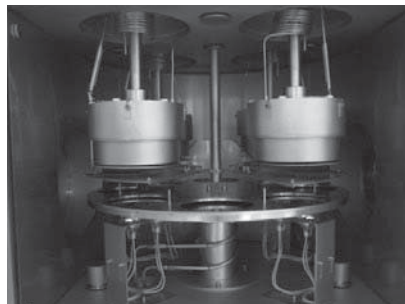

Chamber bottom: rotating substrate table with four heating stations
Chamber top: four magnetron sputter sources



Multiple targets for ion sputtering

Technical Data

UNIVEX 600

Vacuum chamber		Water-cooled
Material		
Chamber body		Stainless steel
Chamber door		Stainless steel
Dimensions		
Inside width	mm	600
Inside depth	mm	600
Inside height	mm	800
Connections ¹⁾		
Front side		Door with window
Rear side	DN	1 x 250 ISO-K (pump system connection), 2 x 16 ISO-KF, 2 x 25 ISO-KF, 2 x 40 ISO-KF
Bottom plate		Variable connections
Cover plate		1 x 250 ISO-K, 4x installation bore ø 34,5 mm
High vacuum pump		TURBOVAC MAG W 1300 iP
Nominal pumping speed for N ₂	l x s ⁻¹	1100
Backing pump		SOGEVAC SV 65 B
Nominal pumping speed	m ³ x h ⁻¹	59
Controller		PLC with graphic touchscreen
Required supplies		
Voltage		400 V, 3 phases / N / PE / 50 Hz ²⁾
Cooling water		
Inlet pressure	bar (abs.)	4 to 6
Consumption, approx.	l x min ⁻¹	Dependent on chamber installations
Feed temperature	°C	+18 to +25
Compressed air	bar (abs.)	4 to 6
Weight, approx.	kg	1000 ³⁾

¹⁾ Standard configuration, other hole patterns / flanges / viewing windows upon request

²⁾ Other voltages and frequencies upon request

³⁾ Total weight without chamber installations/process components

Ordering Information

UNIVEX 600

	Part No.
UNIVEX 600	upon request

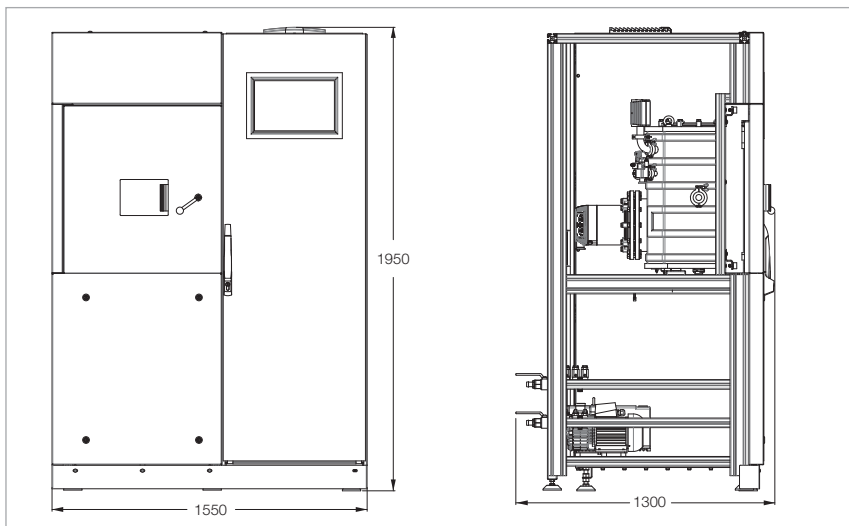

Dimensional drawing for the UNIVEX 600

UNIVEX 900



Design example UNIVEX 900

The UNIVEX 900 is the sophisticated solution for medium to large substrate sizes, respectively for higher substrate throughputs.

In the octagonal vacuum chamber which is 900 mm wide, substrates respectively substrate holders up to an overall diameter of 800 mm max. can be rotated and coated.

The integrated PC/PLC controller allows you to run manual, semiautomatic and fully automatic coating processes

Examples of Equipped Vacuum Chambers

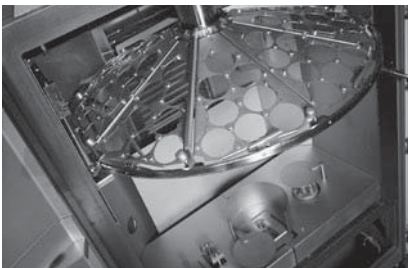

Chamber bottom: electron beam evaporator, thermal evaporator, ion source
Chamber top: rotating substrate dome with turnover device



Rotating substrate table at the chamber top for 10 substrates (in situ combinable with five masks) + 4 high-temperature thermal radiation heaters on the rear

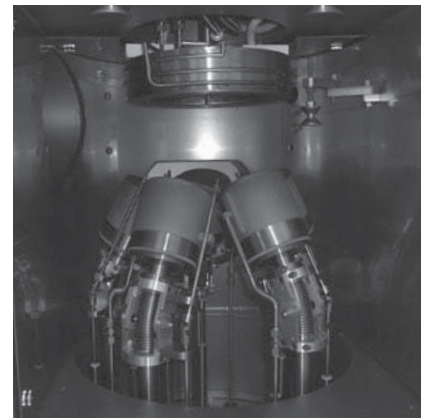

Confocal sputter-up arrangement with rotating high-temperature substrate heater

Technical Data

UNIVEX 900

Vacuum chamber		Water-cooled
Material		
Chamber body		Stainless steel
Chamber door		Stainless steel
Dimensions		
Inside width	mm	900 (octagonal)
Inside depth	mm	900 (octagonal)
Inside height	mm	1100
Connections ¹⁾		
Front side		Door with window
Rear side	DN	2x 250 ISO-K (pump system connection), 2 x 16 ISO-KF, 2 x 25 ISO-KF, 2 x 40 ISO-KF
Bottom plate		Variable connections
Cover plate		1 x 250 ISO-K, 4x installation bore ø 34,5 mm
High vacuum pump		TURBOVAC W 2200 iP
Nominal pumping speed for N ₂	l x s ⁻¹	2100
Backing pump		SOGEVAC SV 100 B
Nominal pumping speed	m ³ x h ⁻¹	97.5
Controller		PLC with graphic touchscreen
Required supplies		
Voltage		400 V, 3 phases / N / PE / 50 Hz ²⁾
Cooling water		
Inlet pressure	bar (abs.)	4 to 6
Consumption, approx.	l x min ⁻¹	Dependent on chamber installations
Feed temperature	°C	+18 to +25
Compressed air	bar (abs.)	4 to 6
Weight, approx.	kg	1500 ³⁾

¹⁾ Standard configuration, other hole patterns / flanges / viewing windows upon request

²⁾ Other voltages and frequencies upon request

³⁾ Total weight without chamber installations/process components

Ordering Information

UNIVEX 900

	Part No.
UNIVEX 900	upon request

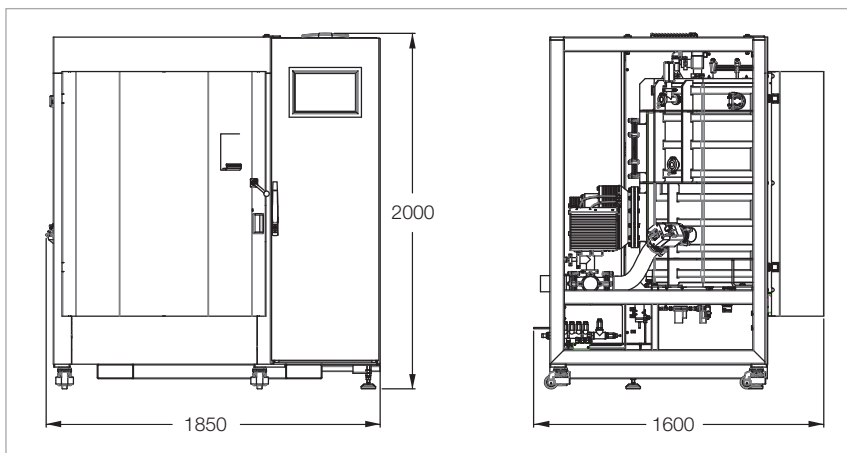

Dimensional drawing for the UNIVEX 900

Glove Box Systems

Multi-purpose Vacuum Coating System for Fitting to a Glove Box

The UNIVEX glove box systems were developed to coat materials which are sensitive with respect to the environmental conditions like oxygen or humidity, for example

Design

- The UNIVEX glove box systems consist of a process module and a separate electrical cabinet
- The process module includes the vacuum chamber, the coating components and the pump system
- The control module includes the PLC, respectively PC controller including the visualisation as well as the power supplies for the process components

Vacuum Chamber

- Box-shaped stainless steel vacuum chambers UNIVEX 250 G - 450 G
- Sliding front door for easy chamber access through the glove box
- Swivelling front door for simple chamber access
- Viewing window with coating protection
- Removable stainless steel coating protection panels
- Flexible connections for chamber bottom and chamber top
- Connecting flanges for pump system and process components

Vacuum System

- Mechanical forevacuum pump (dry compressing or oil sealed)
- High vacuum pump (turbomolecular or cryo pump)
- Vacuum valves
- Pressure measurement devices

Advantages to the User

- Modular system design
- Application-wise optimised system
- Flexible utilisation of the vacuum chamber
- Space saving installation to the rear of the glove box
- Convenient process access through

the glove box by means of a front sliding door

- Easy access to the chamber unit through the rear service door
- Very simple to operate and use
- Suited for retrofitting of process

components (configuration dependent)

- All system components with exception of the sliding door are accessible from outside the glove box



Design example
UNIVEX 350 G, consisting of electrical cabinet (left) and coating module (right)

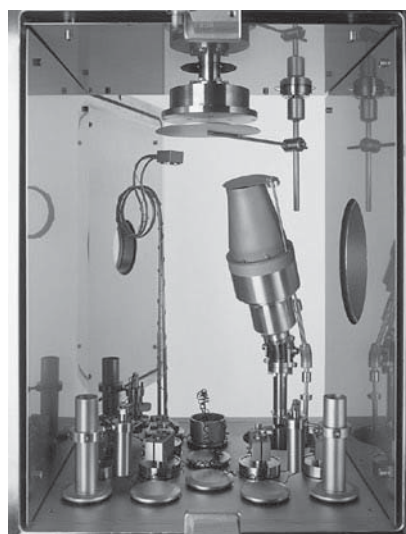

View through the vacuum chamber: front sliding door and rear swivelling door open
Design example with sputter source (right) and heated substrate table (top)

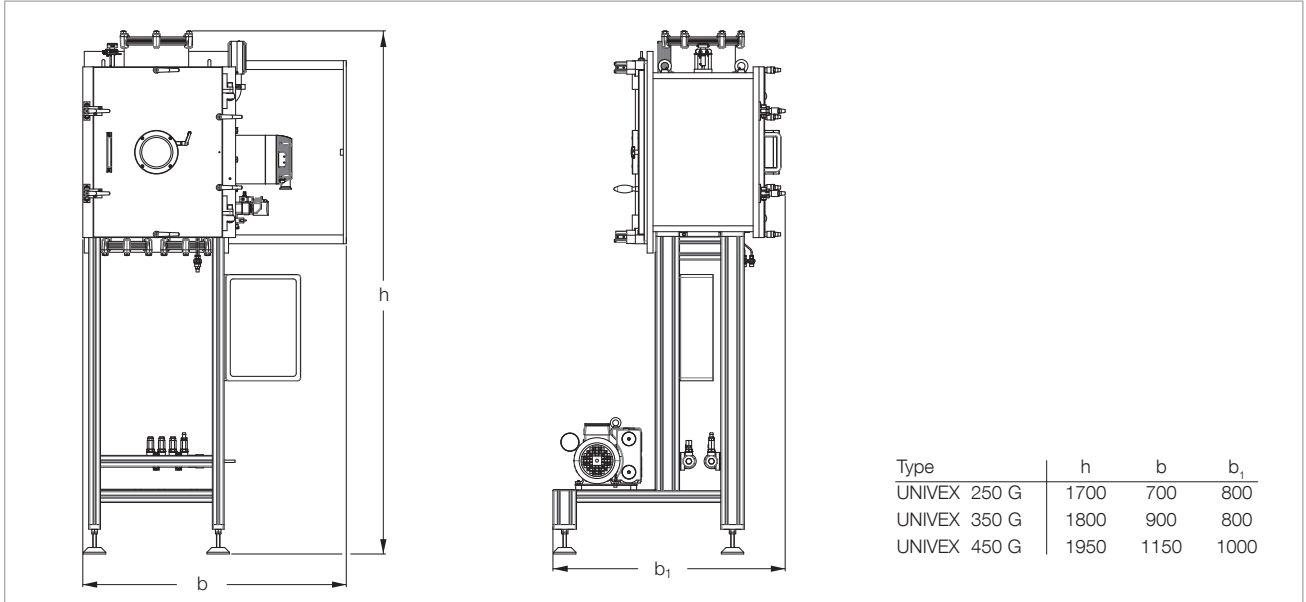

Dimensional drawing of the glove box units, shown without process installations

Complete Solutions, including Glove Box

Upon request Oerlikon Leybold Vacuum will also arrange the delivery of turnkey solutions consisting of the UNIVEX 350 G coating system and a glove box from a single source.

For this, please ask us for a quotation.

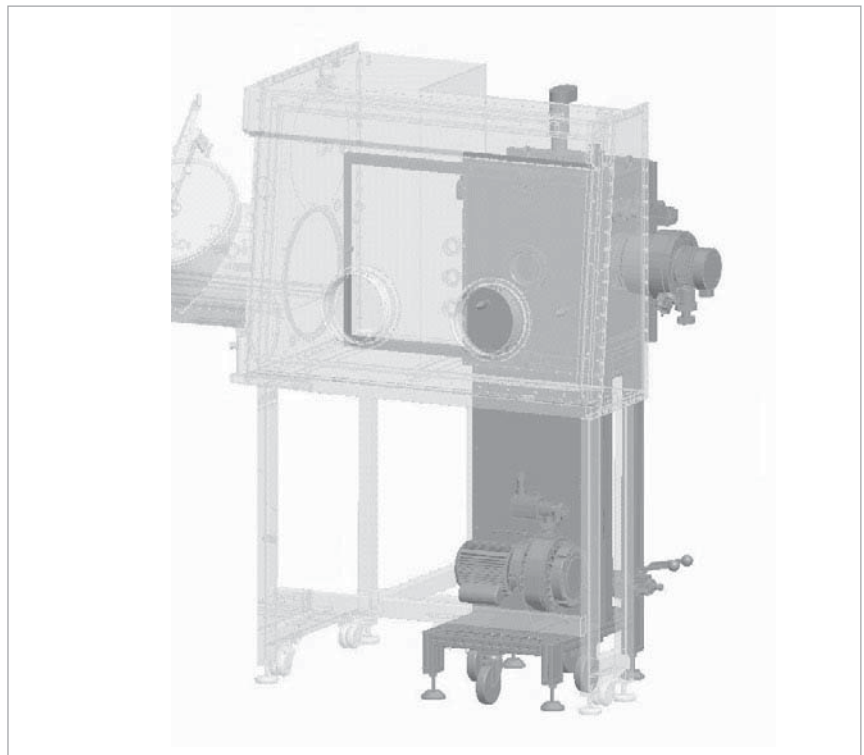

3D view of a glove box with the UNIVEX 350 G coating module fitted to the rear

UNIVEX 250 G

The UNIVEX 250 G is a convenient and cost-effective solution for coating tasks requiring not much space.

Substrates, respectively substrate holders up to an overall diameter of

approximately 220 mm can be processed.

Technical Data

UNIVEX 250 G

Vacuum chamber		
Material		
Chamber body		Stainless steel
Front sliding door		Stainless steel
Rear swivelling door		Aluminum
Dimensions		
Inside width	mm	270
Inside depth	mm	370
Inside height	mm	400
Connections ¹⁾		
Front side		Sliding door for glove box access; manually operated and pneumatically closing turning door for service access; manually locked
rear side		
Bottom plate		Variable connections
Cover plate		1 x 200 ISO-K, 2 x installation bore \varnothing 34,5 mm
Left side	DN	1 x 160 ISO-K (pump system connection), 2 x 16 ISO-KF, 1 x 25 ISO-KF
High vacuum pump		TURBOVAC 350 i
Nominal pumping speed for N ₂	l x s ⁻¹	290
Backing pump		SOGEVAC SV 10 B
Nominal pumping speed	m ³ x h ⁻¹	11
Controller		PLC with graphic touchscreen
Required supplies		
Voltage		400 V, 3 phases / N / PE / 50 Hz ²⁾
Cooling water		
Inlet pressure	bar (abs.)	4 to 6
Consumption, approx.	l x min ⁻¹	Dependent on chamber installations
Feed temperature	°C	+18 to +25
Compressed air	bar (abs.)	4 to 6
Weight, approx.	kg	350 ³⁾

¹⁾ Standard configuration, other hole patterns / flanges / viewing windows upon request

²⁾ Other voltages and frequencies upon request

³⁾ Total weight without chamber installations/process components

Ordering Information

UNIVEX 250 G

	Part No.
UNIVEX 250 G	upon request

UNIVEX 350 G

The UNIVEX 350 G combines a compact design with plenty of chamber space.

For many coating tasks the UNIVEX

350 G offers optimum space conditions and operator convenience as to process components and substrate processing.

Substrates, respectively substrate holders up to an overall diameter of approximately 300 mm can be processed.

Technical Data

UNIVEX 350 G

Vacuum chamber		
Material		
Chamber body		Stainless steel
Front sliding door		Stainless steel
Rear swivelling door		Aluminum
Dimensions		
Inside width	mm	370
Inside depth	mm	380
Inside height	mm	500
Connections ¹⁾		
Front side		Sliding door for glove box access; manually operated and pneumatically closing turning door for service access; manually locked
rear side		
Bottom plate		Variable connections
Cover plate		1 x 200 ISO-K, 4 x installation bore ø 34,5 mm
Left side	DN	1 x 200 ISO-K (pump system connection), 2 x 16 ISO-KF, 1 x 25/50 ISO-KF, 1 x 40 ISO-KF
High vacuum pump		TURBOVAC 450 i
Nominal pumping speed for N ₂	l x s ⁻¹	430
Backing pump		SOGEVAC SV 25 B
Nominal pumping speed	m ³ x h ⁻¹	26
Controller		PLC with graphic touchscreen
Required supplies		
Voltage		400 V, 3 phases / N / PE / 50/60 Hz ²⁾
Cooling water		
Inlet pressure	bar (abs.)	4 to 6
Consumption, approx.	l x min ⁻¹	Dependent on chamber installations
Feed temperature		+18 to +25
Compressed air	bar (abs.)	4 to 6
Weight, approx.	kg	400 ³⁾

¹⁾ Standard configuration, other hole patterns / flanges / viewing windows upon request

²⁾ Other voltages and frequencies upon request

³⁾ Total weight without chamber installations/process components

Ordering Information

UNIVEX 350 G

	Part No.
UNIVEX 350 G	upon request

UNIVEX 450 G

Owing to its chamber dimensions, the UNIVEX 450 G is suited for all coating tasks requiring much space

Substrates, respectively substrate holders up to an overall diameter of over 400 mm can be processed.

With a height of 650 mm, the vacuum chamber is also suited for lift-off applications.

Technical Data

UNIVEX 450 G

Vacuum chamber		
Material		
Chamber body		Stainless steel
Front sliding door		Stainless steel
Rear swivelling door		Aluminum
Dimensions		
Inside width	mm	500
Inside depth	mm	500
Inside height	mm	650
Connections ¹⁾		
Front side		Sliding door for glove box access; manually operated and pneumatically closing
rear side		turning door for service access; manually locked
Bottom plate		Variable connections
Cover plate		1 x 250 ISO-K, 4 x installation bore \varnothing 34,5 mm
Left side	DN	1 x 250 ISO-K (pump system connection), 2 x 16 ISO-KF, 1 x 25 ISO-KF, 1 x 40 ISO-KF
High vacuum pump		TURBOVAC MAG W 700 iP
Nominal pumping speed for N ₂	l x s ⁻¹	590
Backing pump		SOGEVAC SV 40 B
Nominal pumping speed	m ³ x h ⁻¹	44
Controller		PLC with graphic touchscreen
Required supplies		
Voltage		400 V, 3 phases / N / PE / 50/60 Hz ²⁾
Cooling water		
Inlet pressure	bar (abs.)	4 to 6
Consumption, approx.	l x min ⁻¹	Dependent on chamber installations
Feed temperature	°C	+18 to +25
Compressed air	bar (abs.)	4 to 6
Weight, approx.	kg	500 ³⁾

¹⁾ Standard configuration, other hole patterns / flanges / viewing windows upon request

²⁾ Other voltages and frequencies upon request

³⁾ Total weight without chamber installations/process components

Ordering Information

UNIVEX 450 G

	Part No.
UNIVEX 450 G	upon request

Cluster-Tool Systems UNIVEX C



Design example:
UNIVEX 450 C with coating module and electrical cabinet (example photograph).
The coating module consists of two process chambers (left and right) as well as the loadlock and transfer chamber in between
The substrate transfer between the chambers is effected with the aid of a vacuum robot

For special applications we can also supply cluster systems based on the UNIVEX concept. These clusters are equipped according to customer requirements and incorporate separate processing, load lock and transfer chambers.

Frequently sputter applications are involved since sputter targets remain in place for a long time and because of this, the process chambers need to be vented rarely.

Generally, each vacuum chamber will have its own high vacuum system. The load lock chamber is in the simplest case loaded manually with individual substrates. In addition, magazine processing of several substrates per batch is possible.

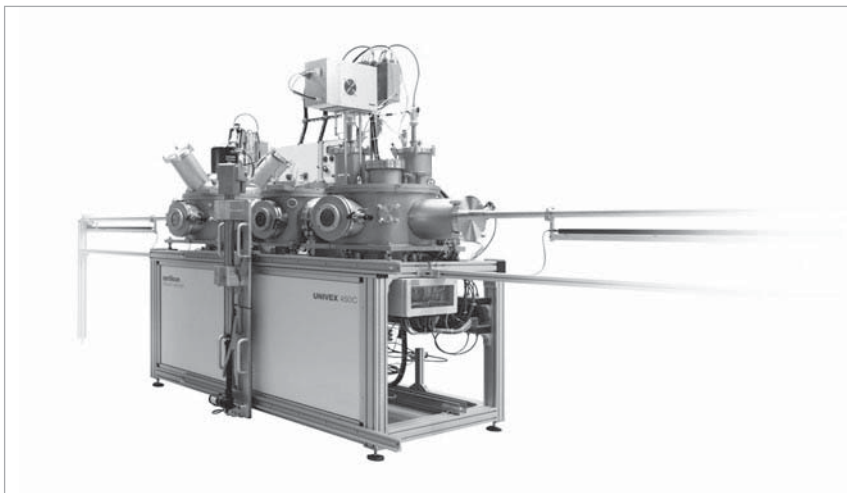

Design example:
UNIVEX 450 C with two process chambers as well as load lock chamber arranged at the centre. The substrates are moved using linear transfer rods (left and right)

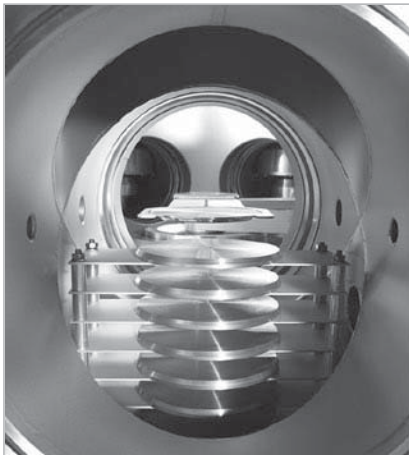

Design example:
Automatically controlled substrate magazine with
robot arm access

For transporting the substrates between the individual vacuum chambers, commonly motor driven robot arms or linear transfer drive units are used.

The UNIVEX control software is customised according to the specific appli-

cation requirements and will generally allow fully automatic running of the process including recipe processing. Additional features like data logging, password protected and priority dependent user access as well as remote access for servicing can be optionally integrated.

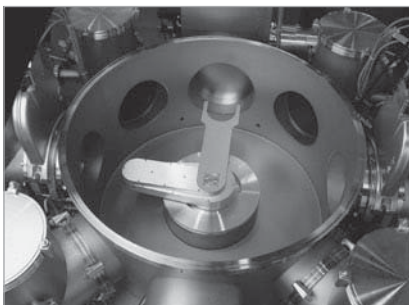

Design example:
Load lock chamber with central vacuum robot for
substrate transportation into radially arranged pro-
cess chambers

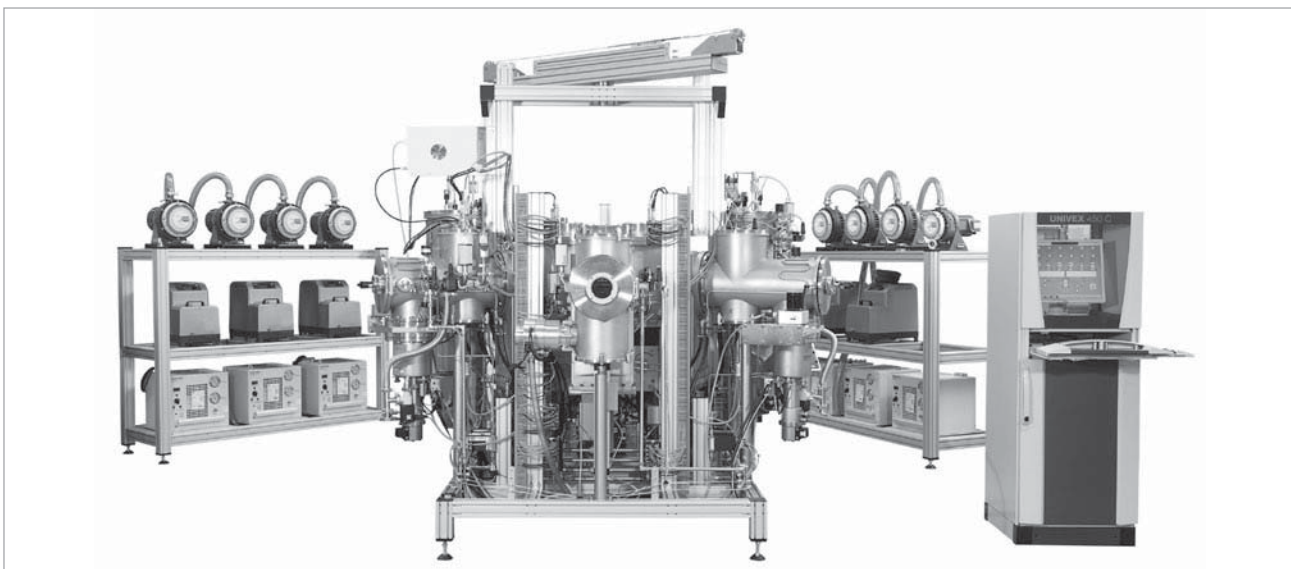

Design example:
Coating module (centre) with decentralised pump systems (left and right) and control console

Dactyloscopy Systems UNIVEX D

Oerlikon Leybold Vacuum has developed a coating system, which relies on a recognized metal evaporation process to reveal fingerprints on items containing fingerprint evidence.

Benefits of this method

- Easily controllable thermal coating process
- Coating of large areas is possible up to 800 x 400 mm
- Short cycle times are possible (depending on the material with the fingerprint evidence)
- Good contrast on multicolour surfaces
- The material containing the fingerprint evidence remains undamaged



Design example:
UNIVEX 450 D, consisting of vacuum coating module (right) and separate electrical cabinet (left)



Opened coating chamber with retracted substrate receiver

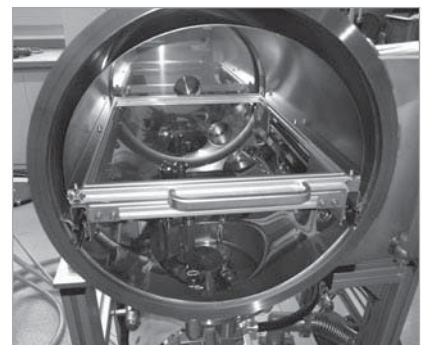

View into the chamber with thermal evaporator and positioned substrate receiver

Space Simulation Systems UNIVEX S

We are offering the UNIVEX S line for simulation of space conditions as well as other thermal vacuum experiments. It generally consists of a cylindrical vacuum chamber with high vacuum sys-

tem and supply module with process controller. The simulation chamber is typically equipped with temperature controllable trays and shrouds, which may be both

heated and cooled, in a vacuum. The process module is moved manually along rails so that the simulation chamber can be opened for loading



Design example:
UNIVEX 1000 S with closed simulation chamber



Opened chamber of the UNIVEX 1000 S with temperature controllable shrouds and substrate tray

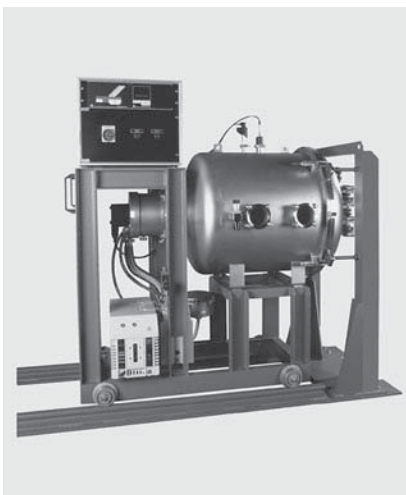

Design example:
UNIVEX 700 S

Process Accessories

Thermal Evaporation of High Melting Point Materials (metals)

Single Thermal Evaporator

Consisting of two water-cooled high voltage feedthroughs with terminal blocks for 34.5 mm dia. holes.

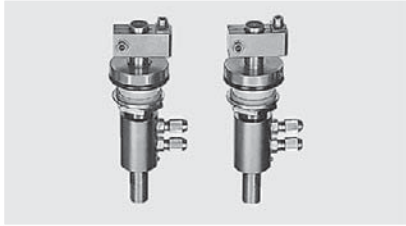

Single thermal evaporator

Technical Data

Rating per conductor	V	max. 100
	A	500
Seals		FPM (FKM)
Water connection	mm	Hose 4/6 dia.
Weight	kg	2.5

Single Thermal Evaporator

Ordering Information

	Part No.
Single thermal evaporator	upon request

Single Thermal Evaporator

Dual Thermal Evaporator

Consisting of three water-cooled high voltage feedthroughs with terminal blocks for 34.5 mm dia. holes.

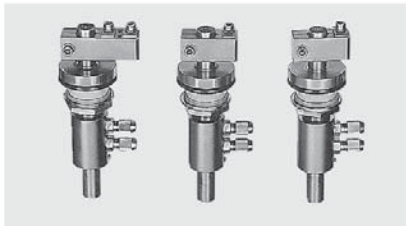

Dual thermal evaporator

Technical Data

Rating per conductor	V	max. 100
	A	500
Seals		FPM (FKM)
Water connection	mm	Hose 4/6 dia.
Weight	kg	3.9

Dual Thermal Evaporator

Ordering Information

	Part No.
Dual thermal evaporator	upon request

Dual Thermal Evaporator

High Current Cable

For single and dual thermal evaporators, equipped with terminals and clamping pieces.

Technical Data

Length	m	2 ¹⁾
Rating	V	max. 100
	A	500
Cross section	mm ²	120
Weight	kg	3.5

High Current Cable

Ordering Information

	Part No.
Power supply cable	upon request ²⁾

High Current Cable

¹⁾ Standard length. Other lengths can be specified

²⁾ For the single thermal evaporator, two high current cables are required
For the dual thermal evaporator, three high current cables are required

AS 153 High current power supply unit

For supplying thermal evaporators.



AS 153 high current power supply unit

Technical Data

Cabinet	19" rack module, 2 HU Installation depth 520 mm
Output voltage/current, max.	8 V, 400 A
Inputs	Remote control unit for controlling the evaporation power (0 to 10 V)
Main power supply	230 V, 50/60 Hz, 10 A
Weight, approx.	kg 10

Power Supply Unit

Ordering Information

	Part No.
AS 153 high current power supply unit	upon request

Power Supply Unit

Thermal Evaporation of Low Melting Point Materials (organics)

Organic material evaporators are special instruments based on the thermal principle developed to evaporate mostly temperature sensitive organic materials. Such instrumentation ensures a coating

process at precisely controlled heating temperatures in the range between 50 °C and 600 °C.

For installation within the UNIVEX systems, Oerlikon Leybold Vacuum

supplies organic material evaporators as a complete package, consisting of evaporator source, automatic evaporator shutter and 19" rack mount controller.

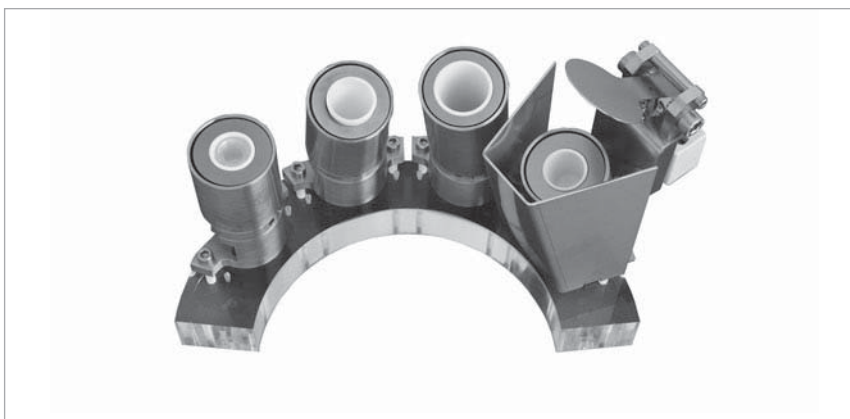

Four organic material evaporators, arranged in a semicircle



Single organic material evaporator with shutter, fitted to a DN 40 CF flange



Power supply unit for two organic material evaporators

Upon request we shall be pleased to provide an offer which specifically matches the requirements of your application.

Electron Beam Evaporation

Various models of electron beam evaporators and power supplies are available for installation in the UNIVEX systems.

Electron Beam Evaporator

The selection of a suitable electron beam evaporator will primarily depend on the amount of available space, the desired evaporation rate and the film thickness as well as the number and type of materials which need to be evaporated. Single crucible as well as rotatable multi-crucible evaporators are available.

Power Supplies

The power supply unit for the individual electron beam evaporators is selected depending on the maximum evaporation power which is required, as well as the demanded properties for X/Y beam deflection. Models with output power ratings ranging from 3 kW to 10 kW are available.

Upon request we shall be pleased to provide an offer which specifically matches the requirements of your application.

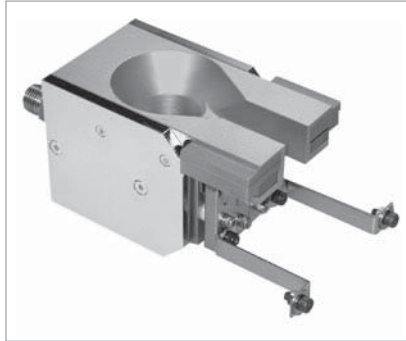

Electron beam evaporator with single crucible

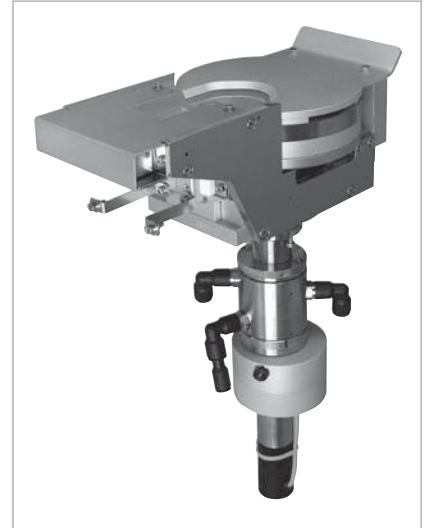

Electron beam evaporator with rotatable six-pocket crucible

Sputtering

Magnetron Sputter Sources

The magnetron sputter sources, which can be built into the UNIVEX systems, are DC/RF compatible. This means, they may be operated either with a DC or also with a RF power supply. In addition, pulsed DC power supplies are possible.

Here as standard round planar sputter sources with target diameters ranging from 2-in. to 6-in. are available. Selection and equipping here depends on the substrate size to be coated, the specified sputtering process and the target material as well as the available installation space.

Other target sizes and magnetron types (rectangular sources, for example) are available upon request.



2-in. magnetron with in-situ tiltable sputter head, pneumatically actuated target shutter and gas feed

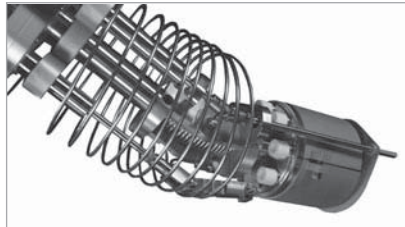

4-in. magnetron with in-situ tiltable sputter head, pneumatically actuated target shutter and gas feed



Confocal arrangement of 3-in. sputter sources, aligned for sputter-up

DC Power Supplies

For DC sputtering, power supply units with a rated output power ranging between 500 W and 3 kW are available. These are 19-in. rack mount units which can be installed in the UNIVEX cabinets.

RF Power Supplies

For RF sputtering, power supply units with a rated output power ranging between 300 W and 2 kW are available. These are 19-in. rack mount units which can be installed in the UNIVEX cabinets.

Moreover, automatically controlled RF matchboxes are supplied for impedance matching between the RF power supply and the magnetron.

Gas Inlet

Sputtering sources can only be operated with a process gas present. For this, manually operated variable leak valves or automatically controlled mass flow controllers are available options.

Throttling the Pumping Speed and Process Pressure Control

In order to protect the high vacuum pump against the high pressures present during plasma operation and to control the process pressure, the UNIVEX systems are fitted with suitable components for throttling the high vacuum pumping speed. These may be butterfly valves, control gate valves or also speed controlled turbomolecular pumps

Upon request we shall be pleased to provide an offer which specifically matches the requirements of your application.

Ion Sources

Ion sources are frequently used to either clean or etch the substrates before running the actual coating process, or to optimise the thin film properties during deposition. In the case of the latter process, the ion source serves to support the coating process (IBAD – Ion Beam Assisted Deposition). However, there are also some PVD processes, during which the ion source is directly needed to produce the thin films, for example during ion beam sputtering

As to design and operating principle, different types of ion sources are available, for example

- Gridded and gridless ion sources
- DC ion sources and RF ion sources
- Flange mounted ion sources and ion sources built in/aligned in the vacuum



Gridless DC ion source with filament for plasma neutralisation



Filamentless RF grid type ion source

We shall be pleased to assist you in connection with your UNIVEX application. For this, please ask us for a quotation.

Process Gas Inlet

In plasma supported processes (sputtering, etching, glow discharge, bias) or reactive deposition methods, generally a gas supply from the outside is necessary. The gas may be supplied either manually with a gas-dosing valve or program-controlled by way of a gas

flow controller (MFC - Mass Flow Controller). The MFC control range is depending on the requirements between approximately 0 to 10 sccm and 0 to 500 sccm.

The available MFC models are equipped either with a 0 to 5 V ana-

logue interface or a EtherCAT interface. The possible gases respectively gas mixtures within a UNIVEX system depend on the type of required application and the installed system hardware (in particular the pump system).

Mass Flow Controller (MFC)

For controlled inlet of gas in connection with automated plasma processes (sputtering, etching, glow discharge). The MFC is controlled by a PC or a PLC provided from the side of the customer.



Technical Data

Gas flow, max.	sccm	selectable between 10 and 500
Supply voltage	V DC	24
Control interface		analog 0 - 5 V or EtherCAT

Mass Flow Controller (MFC)

Ordering Information

	Part No.
Mass flow controller	upon request

Mass Flow Controller (MFC)

Variable Leak Valve with Isolation Valve

For manually controlled inlet of gas in connection with plasma processes (sputtering, etching and glow discharge).

Technical Data

Gas inlet rate q_L	mbar x l x s ⁻¹	5 x 10 ⁻⁶ to 1 x 10 ³
Connection flange	DN	16 ISO-KF

Variable Leak Valve with Isolation Valve

Ordering Information

	Part No.
Variable leak valve with isolation valve	215 010

Variable Leak Valve with Isolation Valve

see also Catalog Part "Valves"

Please ask us for detailed information.

Film Thickness Measurement

Various thin film thickness measuring instruments may be installed in the UNIVEX units.

The selection depends on the measurements needed and the required degree of automation.

As standard, oscillating crystal systems are used. These may consist of one or several sensing heads with or without shutter, and upon request are available for UHV operation (i.e. are suitable for degassing).

The sensor head is driven either by a monitor (allowing only the measurement of deposition rate and film thickness) or by a controller (allowing measurement of the film parameters and control of the deposition rate).

Upon request we can provide an offer which specifically matches the requirements of your application.



Example of a thin film controller

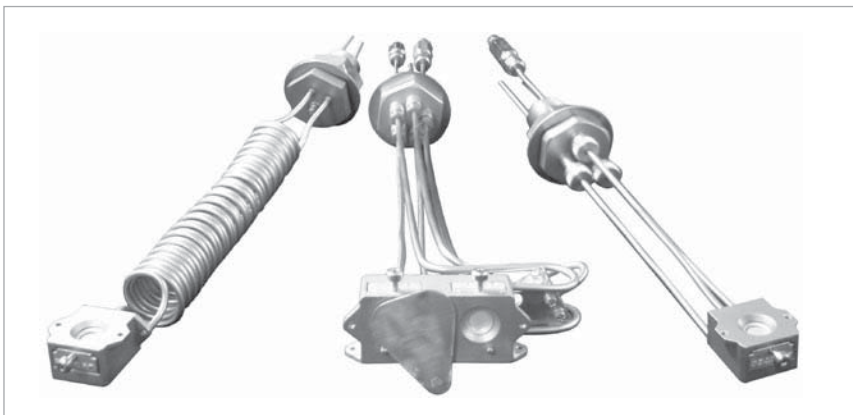

Examples of thin film measurement gauge heads

Substrate Rotation

To attain the desired film properties, a rotary movement of the substrates is very often necessary in deposition processes.

The Oerlikon Leybold Vacuum UNIVEX

system is available with a wide range of substrate rotation accessories. A simple, manually operated rotation axis can be implemented just as a continuously revolving motor shaft or an

angle positionable solution (for placement or transfer tasks). In addition, coaxial drives with two independently operated rotating tables can be offered.

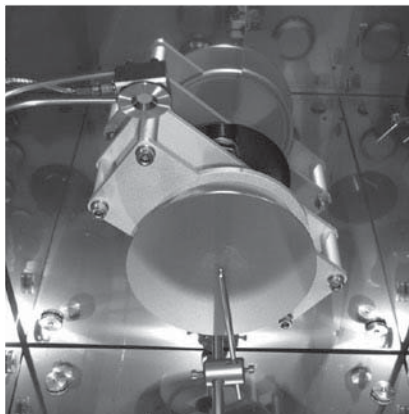

Motor driven rotary drive with a detachable substrate holder (bayonet coupling). View from the bottom onto the closed substrate shutter



Coaxial hollow shaft drive for eccentric rotation and positioning of several substrates, with separate shutter table

Planetary Drives

For high demands regarding thickness uniformity of the deposited film, planetary drives are suitable. Here the substrates, which are to be coated, are

placed on so-called planets. The planets revolve eccentrically about a central axis but they additionally rotate about their own centre point.

Different types of planetary drives are possible depending on the specific kind of task (size and number of substrates, angle of inclination, throughput times).

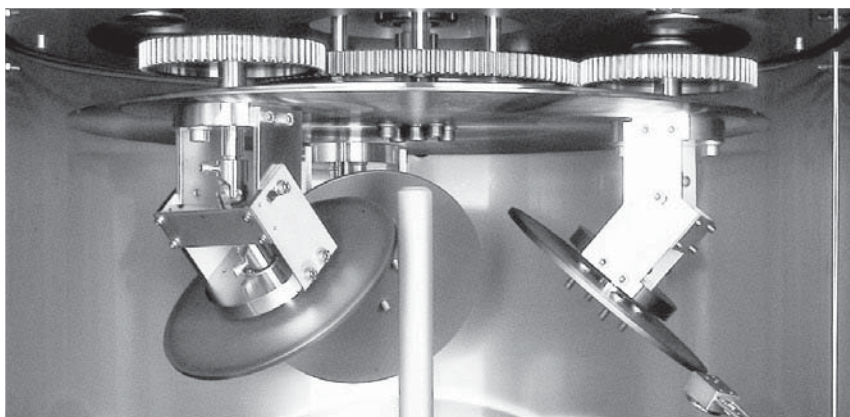

Planetary drive with gear drive and three planets, firmly installed, but where the angle is adjustable

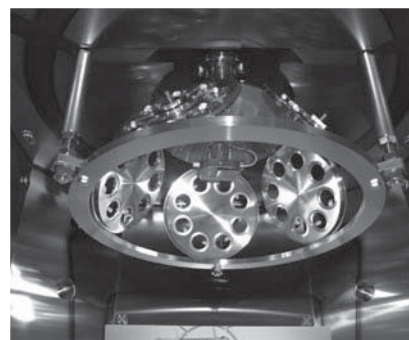

Planetary drive with central friction disc and five free-running planets

Our consulting experts are available to inform you about substrate movement options. For these please ask us for a quotation.

Heating, Cooling, Tempering, Bias

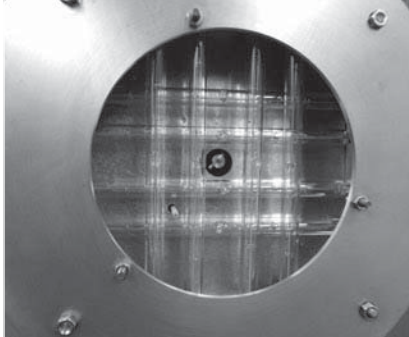

Rotatable thermal radiation heater with quartz lamps

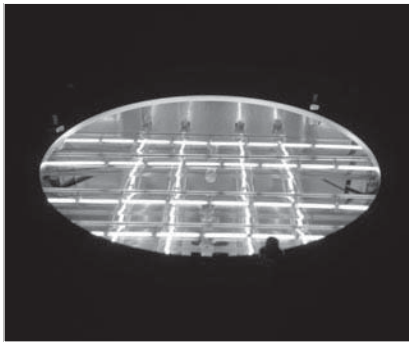

Rotatable thermal radiation heater with quartz lamps during heating operation

The thermal manipulation of substrates is an important method to optimise coating results. For this, Oerlikon Leybold Vacuum offers within the scope of its UNIVEX systems numerous solutions. Depending on requirements and technical feasibility, thermal solutions may also be combined with other properties for example rotation or substrate bias.

Substrate Heating

For temperature-controlled heating, different contact and thermal radiation heaters are available. The selection of the optimal solution depends above all on the desired temperature range, the substrate size and the substrate material.

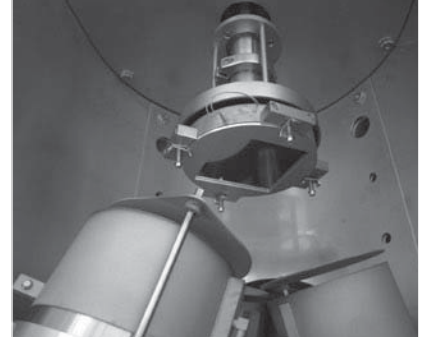

Rotating contact heater based on the resistance heating principle

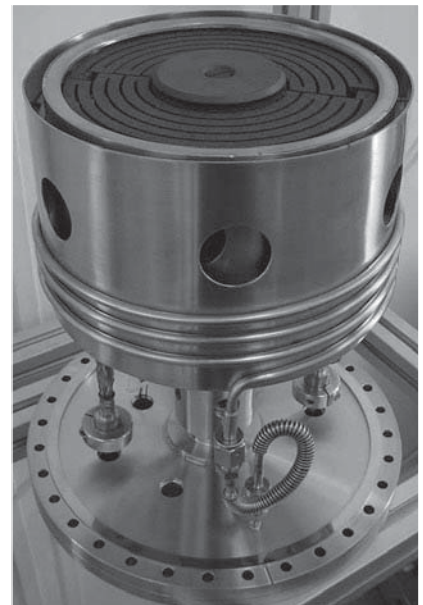

Rotating high temperature thermal radiation heater with SiC heating element

Substrate Cooling

Heat sensitive substrates or substrate coatings necessitate during the deposition process some kind of cooling. Oerlikon Leybold Vacuum offers both inactively as well as actively cooled substrate holders. As cooling media, water, liquid nitrogen (LN₂) or special cooling liquids can be used.

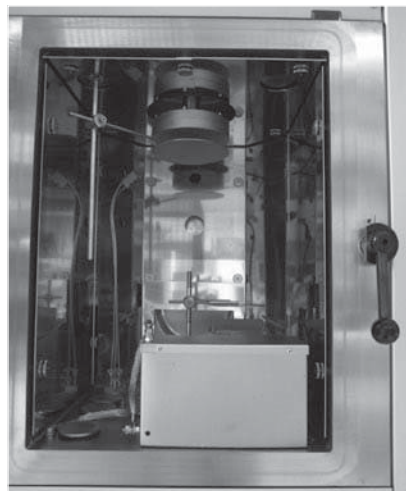

Rotating and water-cooled substrate table

Substrate Tempering

Through the utilisation of a special temperature control liquid, it is possible to heat or also cool a substrate. The possible temperature range lies between approximately $-50\text{ }^{\circ}\text{C}$ and $+150\text{ }^{\circ}\text{C}$ for static substrate holders, respectively $-20\text{ }^{\circ}\text{C}$ and $+100\text{ }^{\circ}\text{C}$ for rotating substrate holders.



Rotatable and temperature controllable substrate holder with substrate shutter

Substrate Bias

Pre-cleaning of the substrate with RF or DC biasing prior to deposition can improve the adhesive properties of the film. Oerlikon Leybold Vacuum offers insulated substrate holders and upon request matching power supplies.

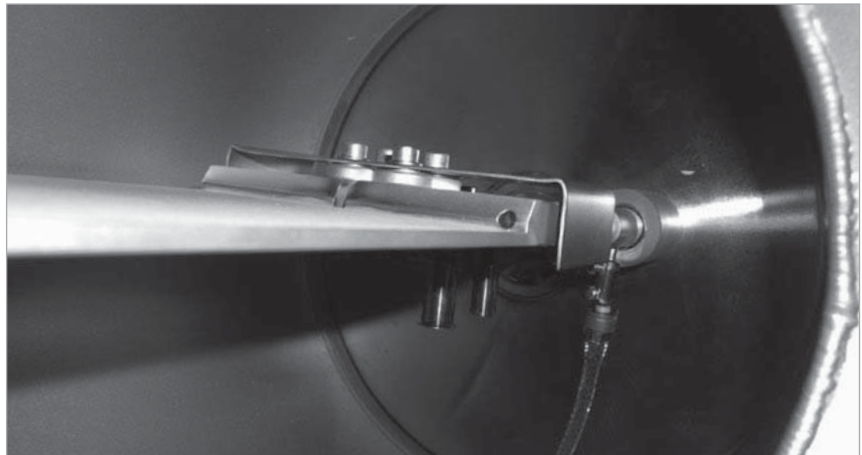

Insulated substrate fork with RF bias connection

Load Lock Systems

To improve the process conditions and to increase coating throughput, frequently additional load lock chambers are used. These are connected to the process chamber and are vacuum-wise separated by a gate valve. By means of a transport facility (linear transfer rod, vacuum robot or alike) the substrate is transported between the chambers. The load lock system offers the advan-

tage to save time during pumpdown and the ability to attain significantly better vacuum pressures in the process chamber, since it will not have to be vented when changing the substrates. Usually the load lock chamber will be significantly smaller compared to the process chamber. Selection of the load lock chamber and

the pump system as well as the design for the substrate transport facility depend on the specific kind of application.

We shall be pleased to assist you as to the possibilities offered by a load lock system in your UNIVEX application.

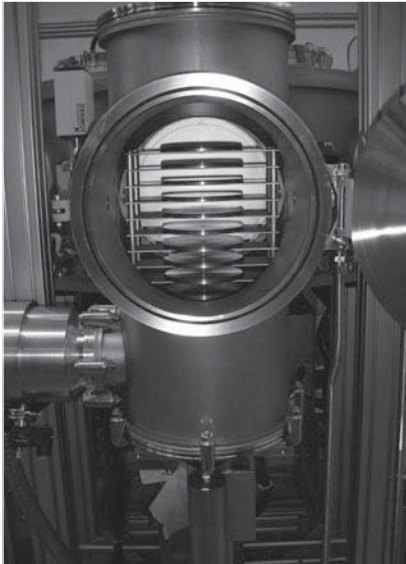

Manually operated load lock chamber with substrate magazine

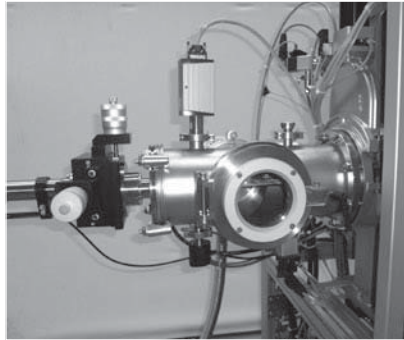

Load lock chamber for a single substrate with automatically operated linear transfer unit

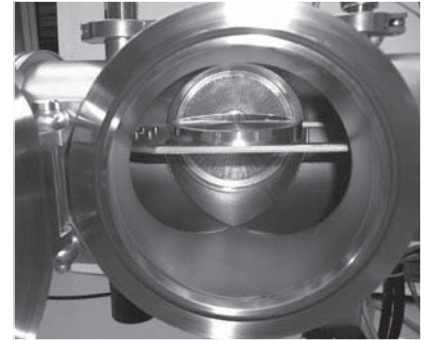

View into the opened load lock chamber onto the substrate end effector

General Accessories

Blank-Off Screw Fitting

For 34.5 mm dia. hole.



Blank-off screw fitting

PS 113 A Low Pressure Safety Switch

Safety interlock arrangements in connection with the UNIVEX system controller, respectively optionally connected power supply equipment (for sputtering or electron beam evaporation, for example).



PS 113 A Safety Switch

Overpressure Safety Valve

For protecting the vacuum chamber against atmospheric overpressure during gas inlet

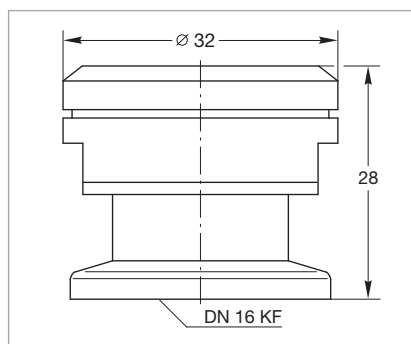

Dimensional drawing for overpressure safety valve

Technical Data

Material	Stainless steel
Seal	FPM (FKM)
Weight	kg 0.1

Blank-Off Screw Fitting

Ordering Information

	Part No.
Blank-off screw fitting	030 40

Blank-Off Screw Fitting

Technical Data

Switching pressure	mbar	approx. 6 below atmospheric pressure
Return switching pressure	mbar	3 below atmospheric pressure
Switching inaccuracy	mbar	2
Switching contact		Changeover contacts, gold-plated, for prog. controls
Switching capacity	mA / V AC mA / V AC	100 / 24 30 / 24
Vacuum connection	DN	16 ISO-KF

Low Pressure Safety Switch

Ordering Information

	Part No.
Low pressure safety switch PS 113 A, DN 16 ISO-KF; complete with 3 m long cable	230 011

Low Pressure Safety Switch

see also Catalog Part "Measuring, controlling"

Technical Data

Responding pressure	mbar	1150 ± 40, over-pressure
Flow at 140 mbar	l x h ⁻¹	500
Valve disk		Spring loaded, with O-ring seal
Leak rate in the closed state	mbar x l x s ⁻¹ (Torr x l x s ⁻¹)	< 1 x 10 ⁻⁸ (< 0.75 x 10 ⁻⁸)
Connection	DN	16 KF

Overpressure Safety Valve

Ordering Information

	Part No.
Overpressure Safety Valve	890 39

Overpressure Safety Valve

see also Catalog Part "High Vacuum Pumps"

Vacuum Feedthrough for the Transfer of Electrical Signals

For installation in a 34.5 mm diameter installation bore.

Connection on the side of the atmosphere through a six-way plug (included in the delivery).

Connection on the vacuum side through a plug with soldered contacts (included in the delivery).

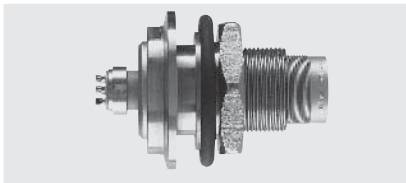

Vacuum feedthrough

Pneumatically Actuated Swivelling Shutter

For covering substrates or coating sources like thermal, respectively electron beam evaporators.

With pneumatic drive unit and shutter panel; for installation within installation bores having a diameter of 34.5 mm.

Technical Data

Rating per conductor	V A	max. 700 16
Seal		FPM (FKM)
Weight	kg	0.3

Ordering Information

	Part No.
Vacuum feedthrough	upon request

Vacuum Feedthrough

Vacuum Feedthrough

Technical Data

Control voltage	V DC	24
Dimensions of the shutter panel	mm	upon consultation

Ordering Information

	Part No.
Pneumatically actuated swivelling shutter	upon request

Pneumatically Actuated Swivelling Shutter

Pneumatically Actuated Swivelling Shutter

Questionnaire

Customer

Substrate

Max. substrate dimensions

Substrate material(s)

Substrate per batch pcs.

Substrate heating yes, max. temp. °C at Substrate or at heater

Substrate cooling yes, min. temp. °C at Substrate or at cooler

Substrate rotation yes

Substrate shutter yes

Substrate pre-treatment (cleaning)

Substrate bias RF DC

Ion beam yes

Sputter etching yes

Deposited film

Coating material(s)

Layers per substrate pcs.

Any materials incompatible with your coating process (i.e. aluminum, copper, viton, etc.)

yes, these materials are

Deposition process

Thermal evaporation yes

Number of sources pcs.

Number of power supplies pcs.

Source shutter(s) yes

Electron beam evaporation yes

Number of guns pcs.

Number and size of pockets (e.g. 1 x 8cc, 4 x 8cc, 6 x 20cc ...)

Evaporating power 3 kW 5 kW 6 kW 10 kW

Source shutter(s) yes

Thickness measurement monitor controller

Magnetron sputtering yes

Target to substrate alignment confocal face to face

Source shutter(s) yes

Number of DC sputter sources pcs.

Target diameter 2" 3" 4" 6"

Targets with special size

Number of DC power supplies pcs.

Number of RF sputter sources pcs.

Target diameter 2" 3" 4" 6"

Targets with special size

Number of RF power supplies pcs.

Ion assisted deposition yes

Questionnaire

Gas inlet (required for all plasma processes)

Required gases

Gas inlet system MFC manual leak valve

Vacuum chamber

Best suited standard size yes

If not, then special size

Chamber wall tempering cooling heating (by water, max. 65 °C)

Additional load lock system manual automatic with magazine for substrates

Pump system

Fore-vacuum pump dry oil-sealed

High vacuum pump cryo turbomolecular

Process pressure mbar/ Torr

Ultimate pressure mbar/ Torr

System control

(Standard is PLC with automatic pump system control and manual deposition control)

Manual process control yes (i.e. manual deposition steps)

Semi-automatic proc. control yes (i.e. automatic single deposition steps)

Automatic process control yes (i.e. automatic coating batches, recipe-processing)

Installation

Location

in a clean room completely yes

in the clean room wall yes

Main power supply

Voltage V

Number of phases

Frequency Hz

Description of other process or system issues, if required

Commercial aspects

Estimated budget currency EUR USD CHF

Planned delivery date

Calibration Systems

General

CS Calibration Systems

The requirements imposed on vacuum engineering with regard to accuracy of the measurements, reproducibility and unambiguity of the determined vacuum pressures have increased steadily over the last years

Routine calibrations of vacuum gauges are an important component of quality assurance schemes. The calibration systems from Oerlikon Leybold Vacuum put the customer in a position to check and recalibrate on his own the specified and necessary accuracy of his vacuum gauges.

Calibration systems are available for this purpose which cover a calibration range from 1000 mbar to 1×10^{-7} mbar (750 to 0.75×10^{-7} Torr).

Each system is equipped with several certified reference pressure sensors (transmitter standards), which each cover a part of the specified range of calibration pressures. In the pump system, turbomolecular pumps TURBOVAC with DIVAC diaphragm pumps are used. A variable leak valve is used to let the gas into the calibration chamber. In the case of the calibration system CS7, the gas inlet line is, moreover, equipped with its own pump system.

The CS 3 mobile is an implementation which may be easily transported in a space saving manner. To this end it may be disassembled in to 2 parts for subsequent on-site reassembly.

The CS7 is equipped with a heater for the vacuum chamber, for the purpose of attaining lower chamber pressures more rapidly. The temperature of the heating collars can be controlled whereby the maximum degassing temperature will depend on the components installed (flanges, pressure sensors, valves).

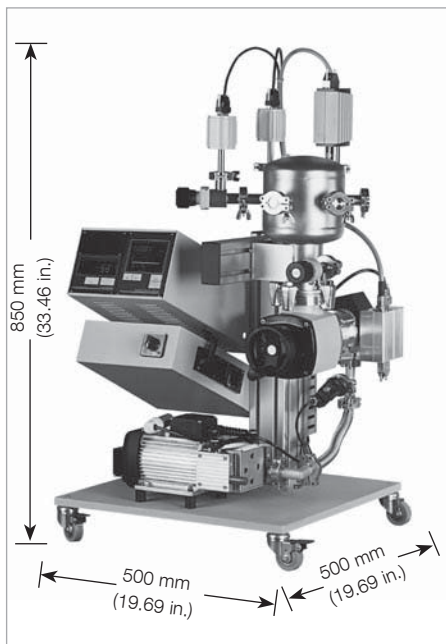

CS3 calibration system

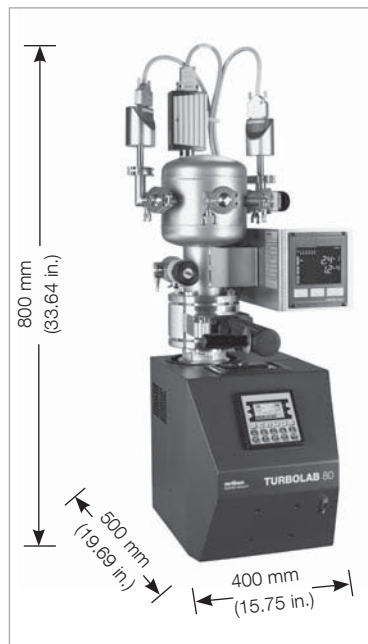

Calibration system CS3 mobile

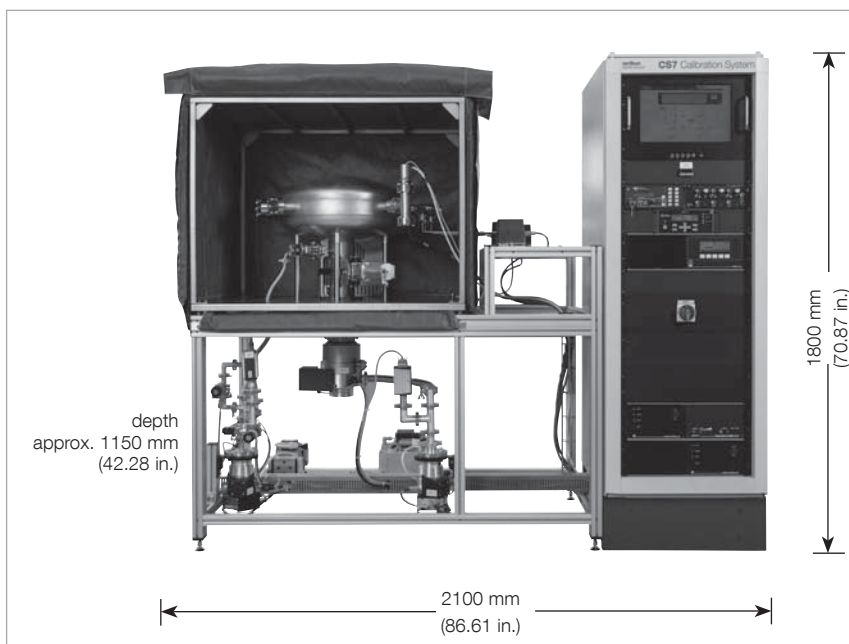

CS7 calibration system

Advantages to the User

- Vacuum gauges and measurement systems of any make may be calibrated
- Designed in accordance with DIN 28 418 resp. ISO/DIS 3567
- Transfer standards with PTB-, DAKKS- or factory certificate
- Easier DIN/ISO 9000 approval
- Reliable and reproducible measurements
- Quick start-up
- Measurement system free of hydrocarbons through the utilisation of dry compressing vacuum pumps
- Simple operation
- CE approval

Products

Technical Data

Calibration System

		CS3 / CS3 mobile	CS7
Calibration range	mbar (Torr)	1000 to 1×10^{-3} (750 to 0.75×10^{-3})	1000 to 1×10^{-7} (750 to 0.75×10^{-7})
Pressure measurement range	mbar (Torr)	1000 to 2×10^{-6} (750 to 1.5×10^{-6})	1000 to 2×10^{-9} (750 to 1.5×10^{-9})
Vacuum chamber connections (in brackets: quantity available on the side of the customer's system)		5 (3) x DN 16 ISO-KF 1 (0) x DN 25 ISO-KF	6 (3) x DN 16 CF 6 (4) x DN 40 CF
Gas inlet		via variable leak valve	via variable leak valve
Extra pump system for admitting gas		no	yes
Heater for the vacuum chamber		no	yes

Application examples:

Which pressure sensors may be calibrated with which system?

Type of Sensor

Calibration System

	CS3 / CS3 mobile	CS7
Diaphragm sensors		
BOURDONVAC	■	■
Capsule vacuum gauges	■	■
DIAVAC DV 1000	■	■
DI/DU 200/201/2000/2001	■	■
CTR 90, CTR 91, CTR 100 (1000 - 1 Torr full scale)	■	■
CTR 91 (0.1 Torr full scale) / CTR 101		■
THERMOVAC sensors		
TR 301, TR 306	■	■
TR 211, TR 216, TTR 211, TTR 216, TTR 90, TTR 91, TTR 96, TTR 100, TTR 101	■	■
SRG/VISCOVAC sensor (spinning rotor gauge)		
VK 201, SRG		■
PENNINGVAC sensors		
PR 25, PR 26, PR 27, PR 35, PR 36, PR 37, PTR 90, PTR 225		■
IONIVAC sensors		
ITR 90, ITR 100, ITR 200		■
IE 414, IE 514		■

Ordering Information

Calibration System

	CS3 / CS3 mobile	CS7
	Part No.	Part No.
Ordering information and options	upon request	upon request

Sales and Service

Germany

Oerlikon Leybold Vacuum GmbH
Sales, Service, Support Center (3SC)
Bonner Strasse 498
D-50968 Cologne
Phone: +49-(0)221-347 1234
Fax: +49-(0)221-347 31234
sales.vacuum@oerlikon.com
www.oerlikon.com/leyboldvacuum

**Oerlikon Leybold Vacuum GmbH
Sales Area North**
Branch Office Berlin
Industriestrasse 10b
D-12099 Berlin
Phone: +49-(0)30-435 609 0
Fax: +49-(0)30-435 609 10
sales.vacuum.bn@oerlikon.com

**Oerlikon Leybold Vacuum GmbH
Sales Office South**
Branch Office Munich
Karl-Hammerschmidt-Strasse 34
D-85609 Aschheim-Dornach
Phone: +49-(0)89-357 33 9-10
Fax: +49-(0)89-357 33 9-33
sales.vacuum.mn@oerlikon.com
service.vacuum.mn@oerlikon.com

**Oerlikon Leybold Vacuum
Dresden GmbH
Service Competence Center**
Zur Wetterwarte 50, Haus 304
D-01109 Dresden
Service:
Phone: +49-(0)351-88 55 00
Fax: +49-(0)351-88 55 041
info.vacuum.dr@oerlikon.com

Europe

Belgium

**Oerlikon Leybold Vacuum
Nederland B.V.
Belgisch bijkantoor**
Leuvensesteenweg 542-9A
B-1930 Zaventem
Sales:
Phone: +32-2-711 00 83
Fax: +32-2-720 83 38
sales.vacuum.zv@oerlikon.com
Service:
Phone: +32-2-711 00 82
Fax: +32-2-720 83 38
service.vacuum.zv@oerlikon.com

France

**Oerlikon Leybold Vacuum
France S.A.S.**
Parc du Technopolis, Bâtiment Beta
3, Avenue du Canada
F-91940 Les Ulis cedex
Sales and Service:
Phone: +33-1-69 82 48 00
Fax: +33-1-69 07 57 38
info.vacuum.ctb@oerlikon.com
sales.vacuum.ctb@oerlikon.com

**Oerlikon Leybold Vacuum
France S.A.S.**
Valence Factory
640, Rue A. Bergès
B.P. 107
F-26501 Bourg-lès-Valence Cedex
Phone: +33-4-75 82 33 00
Fax: +33-4-75 82 92 69
marketing.vacuum.vc@oerlikon.com

Great Britain

**Oerlikon Leybold Vacuum
UK LTD.**
Unit 9
Silverglade Business Park
Leatherhead Road
Chessington
Surrey (London)
KT9 2QL
Sales:
Phone: +44-13-7273 7300
Fax: +44-13-7273 7301
sales.vacuum.ln@oerlikon.com
Service:
Phone: +44-13-7273 7320
Fax: +44-13-7273 7303
service.vacuum.ln@oerlikon.com

Italy

**Oerlikon Leybold Vacuum
Italia S.r.l.**
Via Trasimeno 8
I-20128 Mailand
Sales:
Phone: +39-02-27 22 31
Fax: +39-02-27 20 96 41
sales.vacuum.mi@oerlikon.com
Service:
Phone: +39-02-27 22 31
Fax: +39-02-27 22 32 17
service.vacuum.mi@oerlikon.com

Netherlands

**Oerlikon Leybold Vacuum
Nederland B.V.**
Floridadreef 102
NL-3565 AM Utrecht
Sales and Service:
Phone: +31-(30) 242 63 30
Fax: +31-(30) 242 63 31
sales.vacuum.ut@oerlikon.com
service.vacuum.ut@oerlikon.com

Switzerland

**Oerlikon Leybold Vacuum
Schweiz AG, Pfäffikon**
Churerstrasse 120
CH-8808 Pfäffikon
Warehouse and shipping address:
Riedthofstrasse 214
CH-8105 Regensdorf
Sales:
Phone: +41-44-308 40 50
Fax: +41-44-302 43 73
sales.vacuum.zh@oerlikon.com
Service:
Phone: +41-44-308 40 62
Fax: +41-44-308 40 60
service.vacuum.zh@oerlikon.com

Spain

**Oerlikon Leybold Vacuum
Spain, S.A.**
C/. Huelva, 7
E-08940 Cornellà de Llobregat
(Barcelona)
Sales:
Phone: +34-93-666 43 11
Fax: +34-93-666 43 70
sales.vacuum.ba@oerlikon.com
Service:
Phone: +34-93-666 46 11
Fax: +34-93-685 43 70
service.vacuum.ba@oerlikon.com

America

USA

**Oerlikon Leybold Vacuum
USA Inc.**
5700 Mellon Road
USA-Export, PA 15632
Phone: +1-724-327-5700
Fax: +1-724-325-3577
info.vacuum.ex@oerlikon.com
Sales:
Phone: +1-724-327-5700
Fax: +1-724-333-1217
Service:
Phone: +1-724-327-5700
Fax: +1-724-325-3577

Brazil

**Oerlikon Leybold Vacuum
Brasil**
Rod. Vice-Prefeito Hermenegildo Tonolli,
nº. 4413 - 6B
Distrito Industrial
Jundiá - SP
CEP 13.212-315
Sales and Service:
Phone: +55 11 2152 0499
Fax: +55 11 99467 5934
sales.vacuum.ju@oerlikon.com
service.vacuum.ju@oerlikon.com

Asia

P. R. China

**Oerlikon Leybold Vacuum (Tianjin)
International Trade Co. Ltd.**
Beichen Economic
Development Area (BEDA),
No. 8 Western Shuangchen Road
Tianjin 300400
China
Sales and Service:
Phone: +86-22-2697 0808
Fax: +86-22-2697 4061
Fax: +86-22-2697 2017
sales.vacuum.tj@oerlikon.com
service.vacuum.tj@oerlikon.com

India

**Oerlikon Leybold Vacuum
India Pvt Ltd.**
No. 82(P), 4th Phase
K.I.A.D.B. Plot
Bommasandra Industrial Area
Bangalore - 560 099
India
Sales and Service:
Phone: +91-80-2783 9925
Fax: +91-80-2783 9926
sales.vacuum.bgl@oerlikon.com
service.vacuum.bgl@oerlikon.com

Japan

**Oerlikon Leybold Vacuum
Japan Co., Ltd.**
Headquarters
Shin-Yokohama A.K.Bldg., 4th floor
3-23-3, Shin-Yokohama
Kohoku-ku, Yokohama-shi
Kanawaga 222-0033
Japan
Sales:
Phone: +81-45-471-3330
Fax: +81-45-471-3323
info.vacuum.yh@oerlikon.com
sales.vacuum.yh@oerlikon.com

Oerlikon Leybold Vacuum Japan Co., Ltd.

Tsukuba Technical Service Center
1959, Kami-yokoba
Tsukuba-shi, Ibaraki-shi 305-0854
Japan
Service:
Phone: +81-29 839 5480
Fax: +81-29 839 5485
service.vacuum.iik@oerlikon.com

Malaysia

**Oerlikon Leybold Malaysia
Oerlikon Leybold Vacuum
Singapore Pte Ltd.**
No. 1 Jalan Hi-Tech 2/6
Kulim Hi-Tech Park
Kulim, Kedah Darul
Aman 09000
Malaysia
Sales and Service:
Phone: +604 4020 222
Fax: +604 4020 221
sales.vacuum.ku@oerlikon.com
service.vacuum.ku@oerlikon.com

South Korea

**Oerlikon Leybold Vacuum
Korea Ltd.**
3F. Jellzone 2 Tower
Jeongja-dong 159-4
Bundang-gu Sungnam-si
Gyeonggi-do
Bundang 463-384, Korea
Sales:
Phone: +82-31 785 1367
Fax: +82-31 785 1359
sales.vacuum.bd@oerlikon.com
Service:
623-7, Ulsung-Dong
Cheonan-Si
Chungcheongnam-Do
Korea 330-290
Phone: +82-41 589 3035
Fax: +82-41 588 0166
service.vacuum.cn@oerlikon.com

Singapore

**Oerlikon Leybold Vacuum
Singapore Pte Ltd.**
8 Commonwealth Lane #01-01
Singapore 149555
Singapore
Sales and Service:
Phone: +65-6303 7030
Fax: +65-6773 0039
sales.vacuum.sg@oerlikon.com
service.vacuum.sg@oerlikon.com

Taiwan

**Oerlikon Leybold Vacuum
Taiwan Ltd.**
No 416-1, Sec. 3
Chunghsin Rd., Chutung
Hsinchu County 310
Taiwan, R.O.C.
Sales and Service:
Phone: +886-3-500 1688
Fax: +886-3-583 3999
sales.vacuum.hc@oerlikon.com
service.vacuum.hc@oerlikon.com

**Oerlikon
Leybold Vacuum GmbH**
Bonner Strasse 498
D-50968 Cologne
Phone: +49-(0)221-347 0
Fax: +49-(0)221-347 1250
info.vacuum@oerlikon.com

oerlikon
leybold vacuum
www.oerlikon.com/
leyboldvacuum